

APPLICATION GUIDE

- MH&W presents CoolBlue® and NaLA® solutions, for the highest reliability and longevity of your VFD motor system!
- VFD's create high frequency damaging common mode currents which travel simultaneously from all outputs to the motor, but also couple back to earth ground.
- If these currents aren't "absorbed" the effect will be lubrication breakdown and electrical discharge machining (EDM) damage in the motor bearing, and electromagnetic interference which affects control signals, encoder feedback, communication links for programmable logic controllers, Remote I/O, metal detectors, pump monitors, and other types of sensors including, ultrasonic sensors, bar code/vision systems, weight, and temperature sensors.

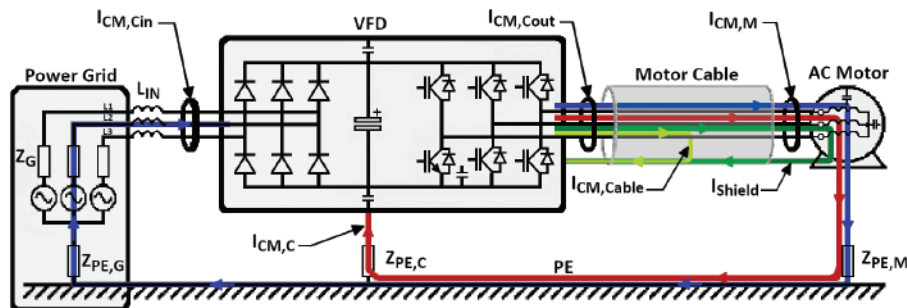

What is CoolBlue®?

CoolBlue® and NaLA® chokes are magnetic nanocrystalline cores that absorb high frequency damaging current before it travels to the motor and coupled back to earth ground. This method eliminates damaging motor bearing currents, EMI, maintenance costs, production down time and protects your system electronics.

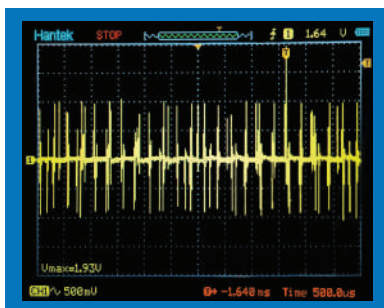

250HP without CoolBlue®

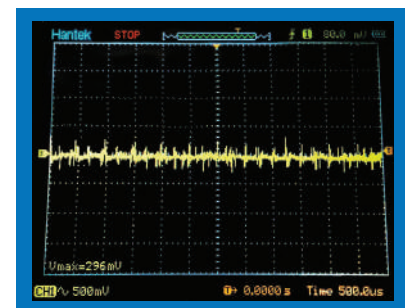
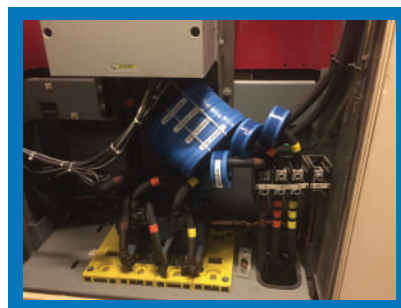

250HP with CoolBlue®

CoolBlue® APPLICATION GUIDE

No Maintenance...unlike shaft grounding devices which are subject to rust, dirt, grease, and worn grounding brushes. **CoolBLUE®** lasts a lifetime and eliminates the need for insulated bearings.

CoolBLUE® Kit Application Guide

PER VFD HORSEPOWER/CABLE LENGTH

VFD HP Size	Cable Length			
	1-150'	151-300'	301-450'	451'+
UP TO 1HP	CBRKIT.0-1HP-150-4C	CBRKIT.0-1HP-300	CBRKIT.0-1HP-450	CBRKIT.0-1HP-451+
1.1-10HP	CBOKIT1.1-10HP-150-4C	CBOKIT1.1-10HP-300	CBOKIT1.1-10HP-450	CBOKIT1.1-10HP-451+
11-40HP	CBOKIT11-40HP-150	CBOKIT11-40HP-300	CBOKIT11-40HP-450	CBOKIT11-40HP-451+
41-50HP	CBOKIT41-50HP-150	CBOKIT41-50HP-300	CBOKIT41-50HP-450	CBOKIT41-50HP-451+
51-100HP	CBOKIT51-100HP-150	CBOKIT51-100HP-300	CBOKIT51-100HP-450	CBOKIT51-100HP-451+
101-428HP	CBOKIT101-428HP-150	CBOKIT101-428HP-300	CBOKIT101-428HP-450	CBOKIT101-428HP-451+
429-1631HP	CBRKIT429-1631HP-150	CBRKIT429-1631HP-300	CBRKIT429-1631HP-450	CBRKIT429-1631HP-451+
1632HP+	CBOKIT1632+HP-150	CBOKIT1632+HP-300	CBOKIT1632+HP-450	CBOKIT1632+HP-451+

- It is important to select kit based on VFD size, not motor. size to ensure you use the correct kit per application.
- Brackets are available from MH&W to help hold cores in place.
- Kits are applicable for servo and DC motors too.

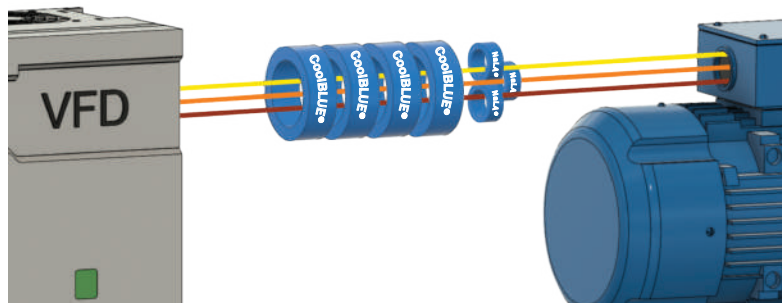

A POWERFUL SOLUTION

NEW FROM MH&W

MH&W presents Magnetec **CoolTUBE®** (Radiated Emission Choke) which replaces the need for shielded motor cabling by absorbing the disrupting, radiated high frequency noise. To use, install the **CoolTUBE®** (correct product per application guide) over the T1+T2+T3 cable.

Contact MH&W for more information on all our products.

FOR MORE INFORMATION

Email us at sales@mhw-filters.com
 Call us at 201.252.8125
 Visit www.mhw-filters.com

MH&W International Corp.
 575 Corporate Drive
 Ste 4200
 Mahwah, NJ 07430