



Mn-Zn & Ni-Zn FERRITE CATALOG

Mn-Zn Ferrite

Material Characteristics

Ferrite for Switching Power Supplies

| | |
|---------------------|----|
| Material List | 8 |
| PC47..... | 9 |
| PC90..... | 10 |
| PC95..... | 11 |
| HS72..... | 12 |
| HS10..... | 13 |

Ferrite for Telecommunication

| | |
|---------------------|----|
| Material List | 14 |
| H5A..... | 15 |
| H5B2..... | 16 |
| H5C2 | 17 |
| H5C3 | 18 |
| HP5..... | 19 |

Large Size Ferrite for High Power

| | |
|---------------------|----|
| Material List | 20 |
| PE22..... | 21 |
| PC40..... | 23 |

Ni-Zn Ferrite

Material Characteristics

| | | |
|-----------------------------|------------|----|
| Material list..... | | 27 |
| For general purpose | L8F | 29 |
| For general purpose | GT2 | 30 |
| For general purpose | GT3 | 31 |
| High Bs | L7H | 32 |
| High Bs | L20H | 33 |
| High Bs | L2H | 34 |
| High Bs | L11H | 35 |
| High Bs | L9H | 36 |
| Low temperature coefficient | L6 | 37 |
| Low temperature coefficient | GT1 | 38 |
| Low temperature coefficient | L6N | 39 |
| Low temperature coefficient | GT8 | 40 |
| Low temperature coefficient | GT4 | 41 |
| Low temperature coefficient | GT10 | 42 |
| Low temperature coefficient | GT6 | 43 |
| Low temperature coefficient | GT9 | 44 |
| Stress-insensitive | T2F..... | 45 |
| Stress-insensitive | T6F..... | 46 |
| Stress-insensitive | T7F..... | 47 |
| Stress-insensitive | T9F..... | 48 |
| Low loss | L17H | 49 |
| Low loss | L18H | 50 |
| Low loss | SY20 | 51 |
| Low loss | SY22 | 52 |
| High Q | L5 | 53 |
| High Q | GT5 | 54 |
| High Q | GT7 | 55 |

MN-Zn Ferrite Cores for Switching Power Supplies

| | |
|--------------------------|-----|
| E Series Cores..... | 56 |
| EI..... | 59 |
| EE, EF..... | 74 |
| EER..... | 87 |
| ETD..... | 100 |
| EP Series..... | 108 |
| EPC Series..... | 112 |
| LP Series..... | 141 |
| Planar Series..... | 148 |
| EL..... | 151 |
| ELT..... | 158 |
| PQI..... | 174 |
| EIR..... | 181 |
| ER..... | 186 |
| EI..... | 194 |
| PQ Series..... | 197 |
| RM Series..... | 229 |
| SMD Series..... | 240 |
| EE..... | 243 |
| ER..... | 243 |
| EEM..... | 243 |
| SP Series (Blocks) | 244 |
| T Series..... | 248 |

MN-Zn Ferrite Cores for Telecommunication

| | |
|----------------|-----|
| EP Series..... | 253 |
| P Series..... | 266 |
| RM Series..... | 287 |
| T Series..... | 300 |

MN-Zn Large Size Ferrite Cores for High Power

| | |
|----------------------|-----|
| Large E Series | 304 |
| EC..... | 307 |
| EIC..... | 315 |
| EE..... | 321 |
| EI..... | 329 |
| ETD..... | 333 |
| Large PQ Series..... | 334 |
| Large T Series..... | 351 |
| Large UU Series..... | 355 |

Ni-Zn Ferrites for EMI suppression

| | |
|-----------------|-----|
| RID Series..... | 368 |
| T Series..... | 372 |

Mn-Zn Sample Kits.....376

| | |
|---------------|-----|
| EMC-A204..... | 377 |
| EMC-A205..... | 378 |
| EMC-A206..... | 379 |

Summary

| | |
|---|-----|
| Overview..... | 383 |
| Terms Definitions and Explanations..... | 384 |

Mn-Zn Ferrite

Material Characteristics

Ferrite for Switching Power Supplies

Ferrite for Telecommunication

Large Size Ferrite for High Power

 **REMINDERS FOR USING THESE PRODUCTS**

Please be sure to read this manual thoroughly before using the products.

The products Listed on this catalog are intended for use in general electronic equipment (AV equipment, telecommunications equipment, home appliances, amusement equipment, computer equipment, personal equipment, office equipment, measurement equipment, industrial robots) under a normal operation and use condition.

The products are not designed or warranted to meet the requirements of the applications listed below, whose performance and/or quality require a more stringent level of safety or reliability, or whose failure, malfunction or trouble could cause serious damage to society, person or property.

When using the products for specific purposes, please first make confirmations in areas such as safety, reliability, and quality.

Please understand that we are not in a position to be held responsible for any damage or the like caused by any use exceeding the range or conditions of this specification sheet or by any use in the specific applications.

- | | |
|---|--|
| (1) Aerospace/Aviation equipment | (8) Public information-processing equipment |
| (2) Transportation equipment (electric trains, ships, etc.) | (9) Military equipment |
| (3) Medical equipment | (10) Electric heating apparatus, burning equipment |
| (4) Power-generation control equipment | (11) Disaster prevention/crime prevention equipment |
| (5) Atomic energy-related equipment | (12) Safety equipment |
| (6) Seabed equipment | (13) Other applications that are not considered general-purpose applications |
| (7) Transportation control equipment | |

When using this product in general-purpose standard applications, you are kindly requested to take into consideration securing protection circuit/equipment or providing backup circuits, etc to ensure higher safety.

Mn-Zn Material List of Ferrite for Switching Power Supplies

MATERIAL CHARACTERISTICS

| Material | Initial permeability μ_i | Core loss volume density (Core loss)* P _{cv} (kW/m ³) B=200mT 100kHz sine wave | | | | Saturation magnetic flux density* B _s (mT) H=1194A/m | | | | Remanent flux density* B _r (mT) H=1194A/m | | | | Coercive force* H _c (A/m) H=1194A/m | | | | Curie temperature T _c (°C) | Density* d _b (kg/m ³) ×10 ³ | Electrical resistivity* ρ _v (Ω·m) |
|----------|---------------------------------|--|------|-------|-------|--|------|-------|-------|---|------|-------|-------|---|------|-------|-------|---|--|--|
| | | 25°C | 60°C | 100°C | 120°C | 25°C | 60°C | 100°C | 120°C | 25°C | 60°C | 100°C | 120°C | 25°C | 60°C | 100°C | 120°C | | | |
| PC47 | 2500±25% | 600 | 400 | 250 | 360 | 530 | 480 | 420 | 390 | 180 | 100 | 60 | 60 | 13 | 9 | 6 | 7 | >230 | 4.9 | 4 |
| PC90 | 2200±25% | 680 | 470 | 320 | 460 | 540 | 500 | 450 | 420 | 170 | 95 | 60 | 65 | 13 | 9 | 6.5 | 7 | >250 | 4.9 | 4 |
| PC95 | 3300±25% | 350 | | 290 | 350 | 530 | 480 | 410 | 380 | 85 | 70 | 60 | 55 | 9.5 | 7.5 | 6.5 | 6 | >215 | 4.9 | 6 |

* Typ.

| Material | Initial permeability μ_i | Relative loss factor tanδ/μi ×10 ⁻⁶ | Saturation magnetic flux density* B _s (mT) H=1194A/m 25°C | Remanent flux density* B _r (mT) H=1194A/m 25°C | Coercive force* H _c (A/m) H=1194A/m 25°C | Curie temperature T _c (°C) | Density* d _b (kg/m ³) ×10 ³ | Electrical resistivity* ρ _v (Ω·m) |
|----------|-------------------------------------|--|--|---|---|---|--|--|
| | | | | | | | | |
| HS72 | 7500±25% (2000min. at 500kHz) | 30(100kHz) | 410 | 80 | 6 | >130 | 4.9 | 0.2 |
| HS10 | 10000±25% | 30(100kHz) | 380 | 120 | 5 | >120 | 4.9 | 0.2 |

* Typ.

Please be sure to request delivery specifications that provide further details on the features and specifications of the products for proper and safe use.
Please note that the contents may change without any prior notice due to reasons such as upgrading.

Mn-Zn Ferrite for Switching Power Supplies **Material List of PC47**

MATERIAL CHARACTERISTICS

| Initial permeability μ_i | Core loss volume density (Core loss)* P_{cv} (kW/m ³) B=200mT 100kHz sine wave | | | | Saturation magnetic flux density* B_s (mT) H=1194A/m | | | | Remanent flux density* B_r (mT) H=1194A/m | | | | Coercive force* H_c (A/m) H=1194A/m | | | | Curie temperature T_c (°C) | Density* ρ_b (kg/m ³) $\times 10^3$ | Electrical resistivity* ρ_v ($\Omega \cdot m$) |
|---------------------------------|--|------|-------|-------|---|------|-------|-------|--|------|-------|-------|--|------|-------|-------|------------------------------------|---|---|
| | 25°C | 60°C | 100°C | 120°C | 25°C | 60°C | 100°C | 120°C | 25°C | 60°C | 100°C | 120°C | 25°C | 60°C | 100°C | 120°C | | | |
| 2500±25% | 600 | 400 | 250 | 360 | 530 | 480 | 420 | 390 | 180 | 100 | 60 | 60 | 13 | 9 | 6 | 7 | >230 | 4.9 | 4 |

* Typ.

μ_i frequency characteristics(Typ.)

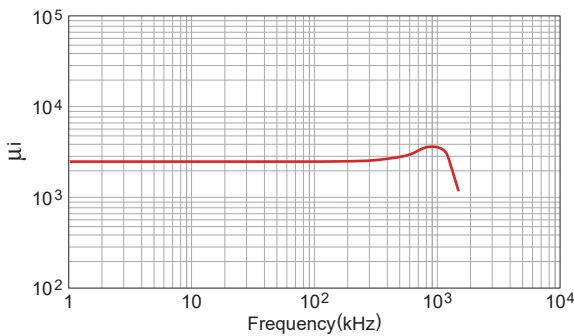

μ_i temperature characteristics(Typ.)

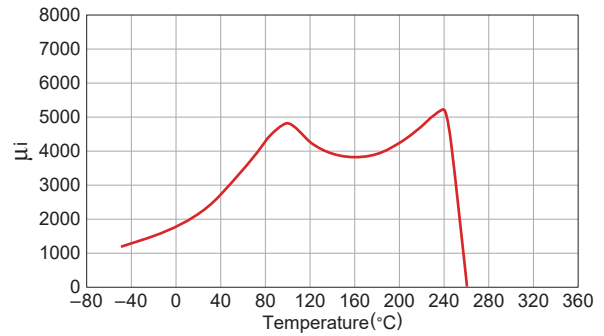

Core Loss(Typ.)

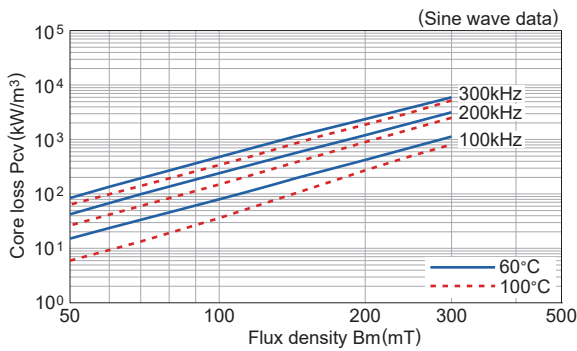

B-H temperature characteristics(Typ.)

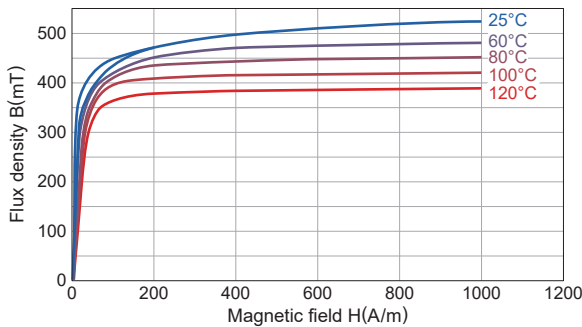

Temperature Dependence of Core Loss(Typ.)

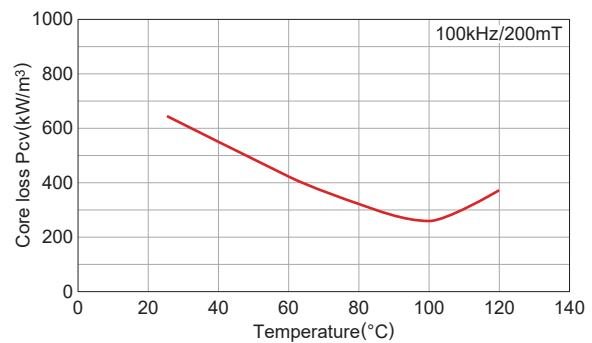

⚠ Please be sure to request delivery specifications that provide further details on the features and specifications of the products for proper and safe use. Please note that the contents may change without any prior notice due to reasons such as upgrading.

Mn-Zn Ferrite for Switching Power Supplies **Material List of PC90**

MATERIAL CHARACTERISTICS

| Initial permeability μ_i | Core loss volume density (Core loss)* Pcv (kW/m ³) B=200mT 100kHz sine wave | | | | Saturation magnetic flux density* Bs (mT) H=1194A/m | | | | Remanent flux density* Br (mT) H=1194A/m | | | | Coercive force* Hc (A/m) H=1194A/m | | | | Curie temperature Tc (°C) | Density* db (kg/m ³) ×10 ³ | Electrical resistivity* ρ_v ($\Omega \cdot m$) |
|------------------------------|--|------|-------|-------|--|------|-------|-------|---|------|-------|-------|---------------------------------------|------|-------|-------|---------------------------|--|---|
| | 25°C | 60°C | 100°C | 120°C | 25°C | 60°C | 100°C | 120°C | 25°C | 60°C | 100°C | 120°C | 25°C | 60°C | 100°C | 120°C | | | |
| 2200±25% | 680 | 470 | 320 | 460 | 540 | 500 | 450 | 420 | 170 | 95 | 60 | 65 | 13 | 9 | 6.5 | 7 | >250 | 4.9 | 4 |

* Typ.

□ μ_i frequency characteristics(Typ.)

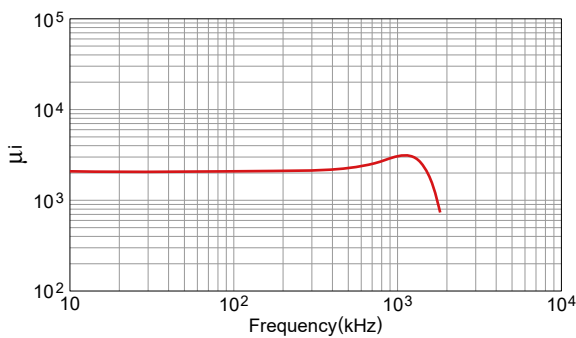

□ μ_i temperature characteristics(Typ.)

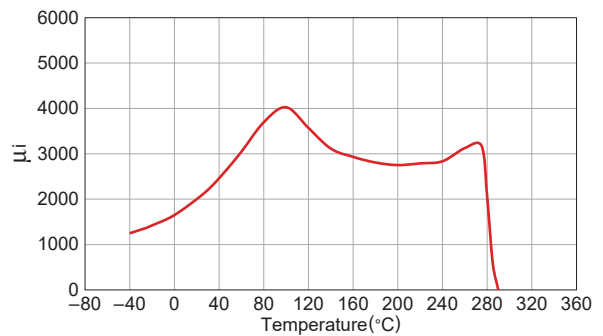

□ B-H temperature characteristics(Typ.)

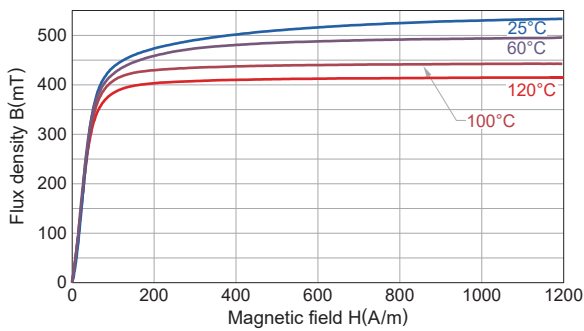

□ Core Loss(Typ.)

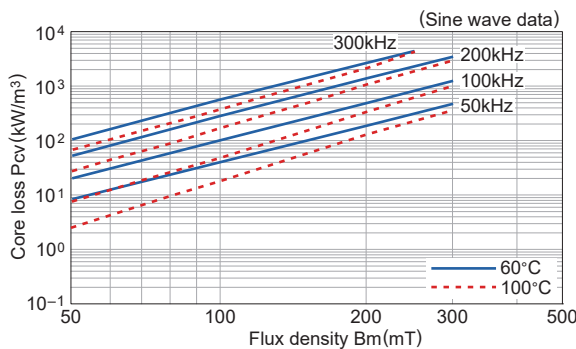

□ Temperature Dependence of Core Loss(Typ.)

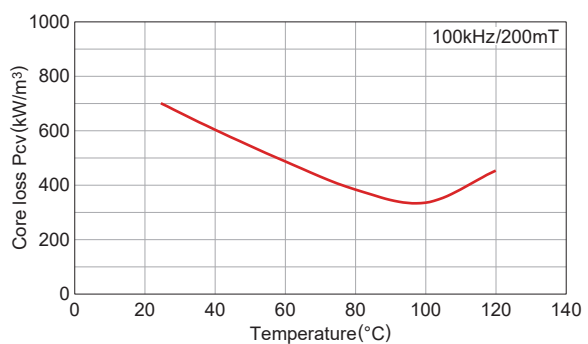

⚠ Please be sure to request delivery specifications that provide further details on the features and specifications of the products for proper and safe use. Please note that the contents may change without any prior notice due to reasons such as upgrading.

Mn-Zn Ferrite for Switching Power Supplies **Material List of PC95**

MATERIAL CHARACTERISTICS

| Initial permeability μ_i | Core loss volume density (Core loss)* Pcv (kW/m ³) B=200mT 100kHz sine wave | | | | Saturation magnetic flux density* Bs (mT) H=1194A/m | | | | Remanent flux density* Br (mT) H=1194A/m | | | | Coercive force* Hc (A/m) H=1194A/m | | | | Curie temperature Tc (°C) | Density* db (kg/m ³) ×10 ³ | Electrical resistivity* ρ_v ($\Omega \cdot m$) |
|------------------------------|--|------|-------|-------|--|------|-------|-------|---|------|-------|-------|---------------------------------------|------|-------|-------|---------------------------|--|---|
| | 25°C | 60°C | 100°C | 120°C | 25°C | 60°C | 100°C | 120°C | 25°C | 60°C | 100°C | 120°C | 25°C | 60°C | 100°C | 120°C | | | |
| 3300±25% | 350 | | 290 | 350 | 530 | 480 | 410 | 380 | 85 | 70 | 60 | 55 | 9.5 | 7.5 | 6.5 | 6 | >215 | 4.9 | 6 |

* Typ.

□ μ_i frequency characteristics(Typ.)

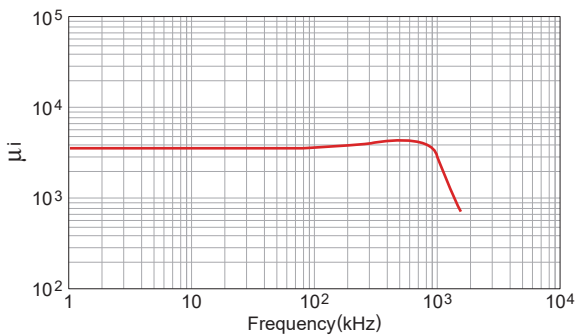

□ μ_i temperature characteristics(Typ.)

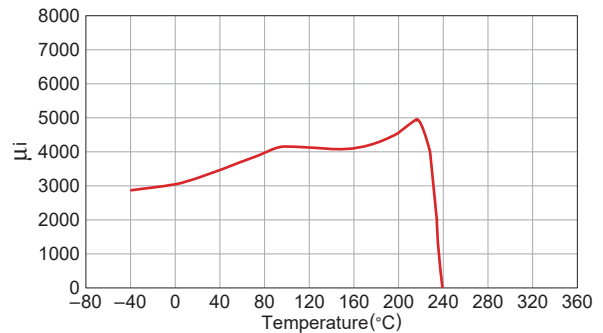

□ B-H temperature characteristics(Typ.)

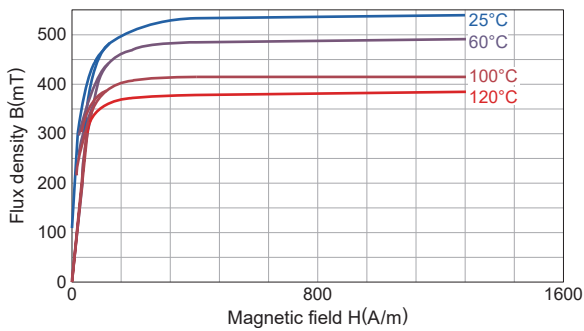

□ Core Loss(Typ.)

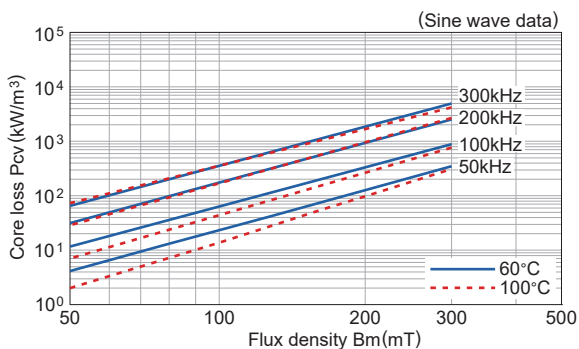

□ Temperature Dependence of Core Loss(Typ.)

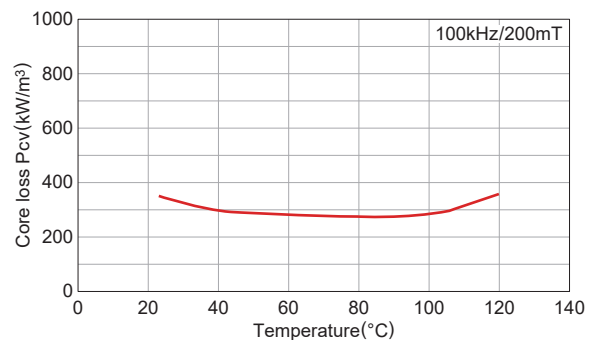

⚠ Please be sure to request delivery specifications that provide further details on the features and specifications of the products for proper and safe use. Please note that the contents may change without any prior notice due to reasons such as upgrading.

Mn-Zn Ferrite for Switching Power Supplies **Material List of HS72**

MATERIAL CHARACTERISTICS

| Initial permeability μ_i | Relative loss factor $\tan\delta/\mu_i$ $\times 10^{-6}$ | Saturation magnetic flux density* B_s (mT) H=1194A/m 25°C | Remanent flux density* B_r (mT) H=1194A/m 25°C | Coercive force* H_c (A/m) H=1194A/m 25°C | Curie temperature T_c (°C) | Density* ρ_b (kg/m ³) $\times 10^3$ | Electrical resistivity* ρ_v ($\Omega \cdot m$) |
|-------------------------------------|--|---|--|--|------------------------------------|---|---|
| 7500±25% (2000min. at 500kHz) | 30(100kHz) | 410 | 80 | 6 | >130 | 4.9 | 0.2 |

* Typ.

μ_i frequency characteristics(Typ.)

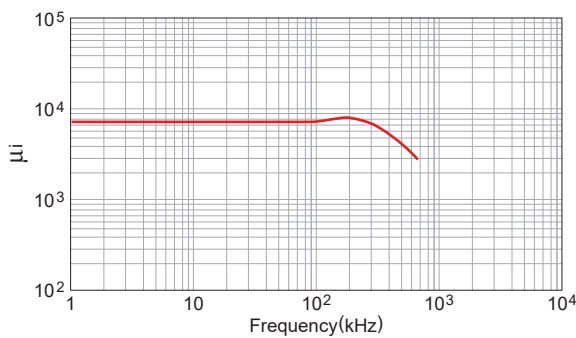

μ_i temperature characteristics(Typ.)

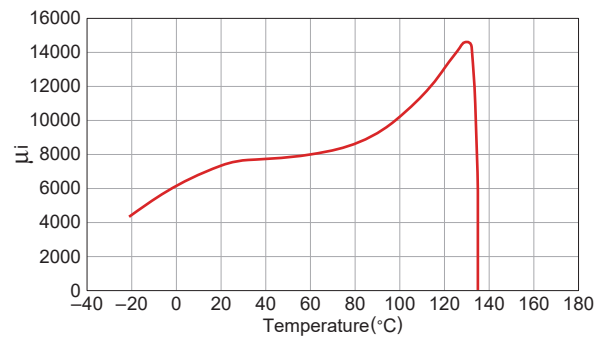

B-H temperature characteristics(Typ.)

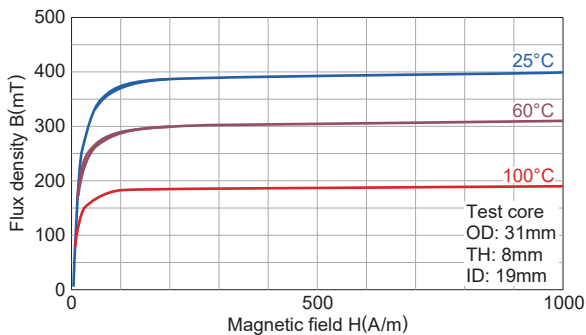

$\tan\delta/\mu_i$ frequency characteristics(Typ.)

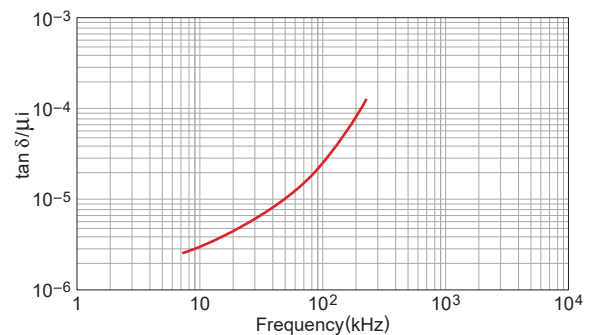

⚠ Please be sure to request delivery specifications that provide further details on the features and specifications of the products for proper and safe use.
Please note that the contents may change without any prior notice due to reasons such as upgrading.

Mn-Zn Ferrite for Switching Power Supplies **Material List of HS10**

MATERIAL CHARACTERISTICS

| Initial permeability μ_i | Relative loss factor $\tan\delta/\mu_i$ $\times 10^{-6}$ | Saturation magnetic flux density* B_s (mT) H=1194A/m 25°C | Remanent flux density* B_r (mT) H=1194A/m 25°C | Coercive force* H_c (A/m) H=1194A/m 25°C | Curie temperature T_c (°C) | Density* d_b (kg/m ³) $\times 10^3$ | Electrical resistivity* ρ_v ($\Omega \cdot m$) |
|---------------------------------|--|---|--|--|------------------------------------|--|---|
| 10000±25% | 30(100kHz) | 380 | 120 | 5 | >120 | 4.9 | 0.2 |

* Typ.

μ_i frequency characteristics(Typ.)

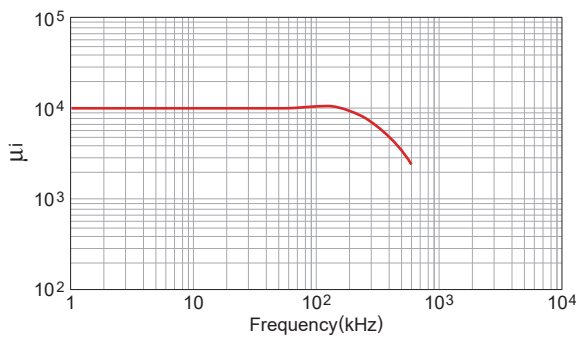

μ_i temperature characteristics(Typ.)

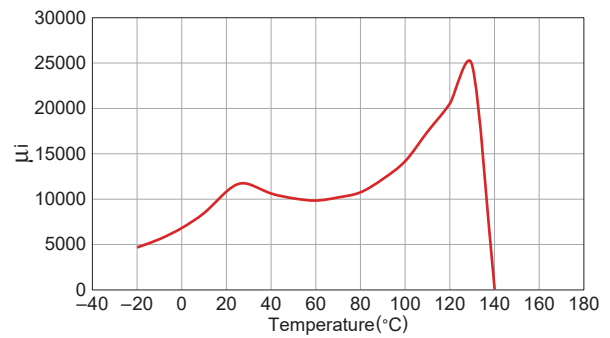

B-H temperature characteristics(Typ.)

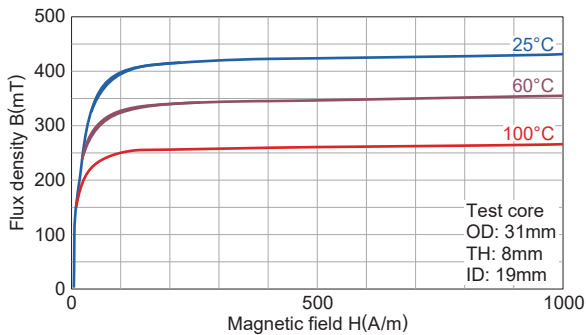

$\tan\delta/\mu_i$ frequency characteristics(Typ.)

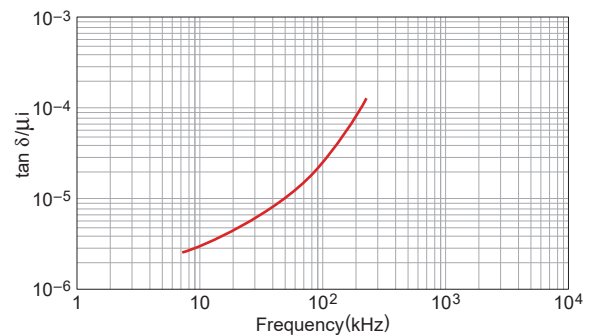

⚠ Please be sure to request delivery specifications that provide further details on the features and specifications of the products for proper and safe use. Please note that the contents may change without any prior notice due to reasons such as upgrading.

Mn-Zn Material List of Ferrite Core for Telecommunication

MATERIAL CHARACTERISTICS

| Material | Initial permeability μ_i | Relative loss factor $\tan\delta/\mu_i$ $\times 10^{-6}$ | Temperature factor of initial permeability $\alpha_{\mu ir}$ $\times 10^{-6}$ -30 to +20°C 0 to 20°C 20 to 70°C | Saturation magnetic flux density* B_s (mT) H=1194A/m 25°C | Remanent flux density* B_r (mT) H=1194A/m 25°C | Coercive force* H_c (A/m) H=1194A/m 25°C | Curie temperature T_c (°C) | Hysteresis material constant ηB $\frac{10^{-6}}{mT}$ | Disaccommodation factor DF $\times 10^{-6}$ | Density* db (kg/m ³) $\times 10^3$ | Electrical resistivity* ρ_v ($\Omega \cdot m$) |
|----------|-------------------------------------|--|--|--|---|---|---|--|--|--|---|
| H5A | 3300 ^{+40%} _{-0%} | <2.5(10kHz) <10(100kHz) | -0.5 to 2.0 — -0.5 to 2.0 | 410 | 100 | 8.0 | >130 | <0.8 | <3 | 4.8 | 1 |
| H5B2 | 7500±25% | <6.5(10kHz) | 0 to 1.8 — 0 to 1.8 | 420 | 40 | 5.6 | >130 | <1.0 | <3 | 4.9 | 0.1 |
| H5C2 | 10000±30% | <7.0(10kHz) | -0.5 to 1.5 — -0.5 to 1.5 | 400 | 90 | 7.2 | >120 | <1.4 | <2 | 4.9 | 0.15 |
| H5C3 | 15000±30% | <7.0(10kHz) | -0.5 to 1.5 — -0.5 to 1.5 | 360 | 105 | 4.4 | >105 | <0.5 | <2 | 4.95 | 0.15 |
| HP5 | 5000±20% | <3.5 | — ±12.5% ±12.5% | 400 | 65 | 7.2 | >140 | <0.4 | <3 | 4.8 | 0.15 |

* Typ.

Mn-Zn Ferrite for Telecommunication **Material List of H5A**

MATERIAL CHARACTERISTICS

| Initial permeability | Relative loss factor | Temperature factor of initial permeability | Saturation magnetic flux density* | Remanent flux density* | Coercive force* | Curie temperature | Hysteresis material constant | Disaccommodation factor | Density* | Electrical resistivity* |
|----------------------|----------------------------|--|------------------------------------|------------------------------------|-------------------------------------|-------------------|----------------------------------|-------------------------|---|----------------------------------|
| μ_i | $\tan\delta/\mu_i$ | $\alpha_{\mu ir}$ | B_s (mT) H=1194A/m 25°C | B_r (mT) H=1194A/m 25°C | H_c (A/m) H=1194A/m 25°C | T_c (°C) | ηB $\frac{10^{-6}}{mT}$ | DF $\times 10^{-6}$ | db (kg/m ³) $\times 10^3$ | ρ_V ($\Omega \cdot m$) |
| 3300 +40% -0% | <2.5(10kHz) <10(100kHz) | -0.5 to 2.0 — -0.5 to 2.0 | 410 | 100 | 8.0 | >130 | <0.8 | <3 | 4.8 | 1 |

* Typ.

μ_i frequency characteristics(Typ.)

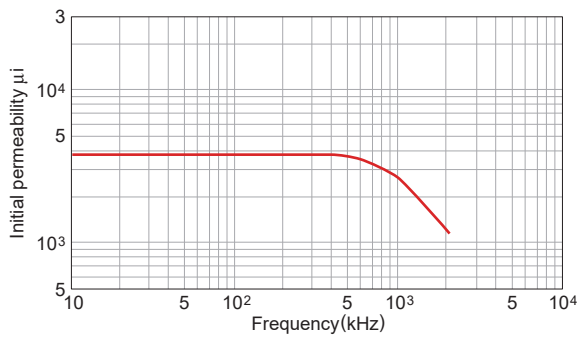

μ_i temperature characteristics(Typ.)

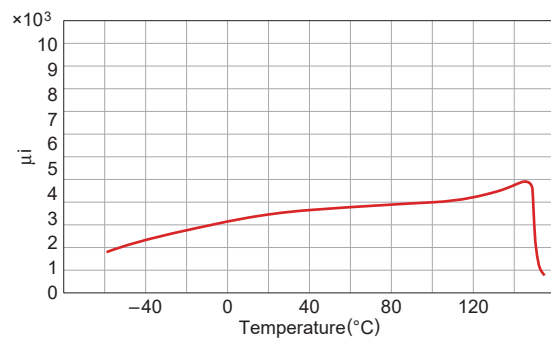

B-H temperature characteristics(Typ.)

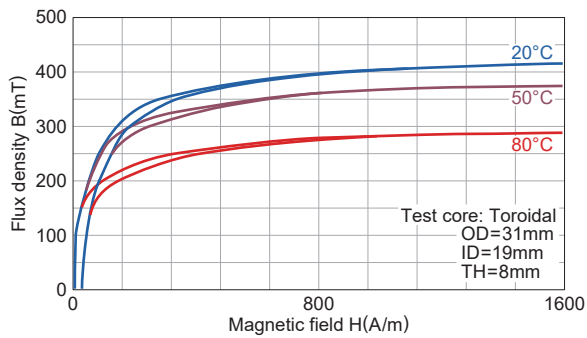

$\tan\delta/\mu_i$ frequency characteristics(Typ.)

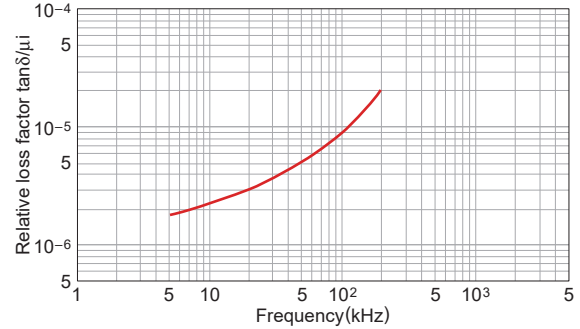

⚠ Please be sure to request delivery specifications that provide further details on the features and specifications of the products for proper and safe use. Please note that the contents may change without any prior notice due to reasons such as upgrading.

Mn-Zn Ferrite for Telecommunication Material List of H5B2

MATERIAL CHARACTERISTICS

| Initial permeability | Relative loss factor | Temperature factor of initial permeability | Saturation magnetic flux density* | Remanent flux density* | Coercive force* | Curie temperature | Hysteresis material constan | Disaccommodation factor | Density* | Electrical resistivity* |
|----------------------|----------------------|--|------------------------------------|------------------------------------|-------------------------------------|-------------------|----------------------------------|-------------------------|---|----------------------------------|
| μ_i | $\tan\delta/\mu_i$ | $\alpha_{\mu ir}$ | B_s (mT) H=1194A/m 25°C | B_r (mT) H=1194A/m 25°C | H_c (A/m) H=1194A/m 25°C | T_c (°C) | ηB $\frac{10^{-6}}{mT}$ | DF $\times 10^{-6}$ | db (kg/m ³) $\times 10^3$ | ρv ($\Omega \cdot m$) |
| 7500±25% | <6.5(10kHz) | 0 to 1.8 — 0 to 1.8 | 420 | 40 | 5.6 | >130 | <1.0 | <3 | 4.9 | 0.1 |

* Typ.

μ_i frequency characteristics(Typ.)

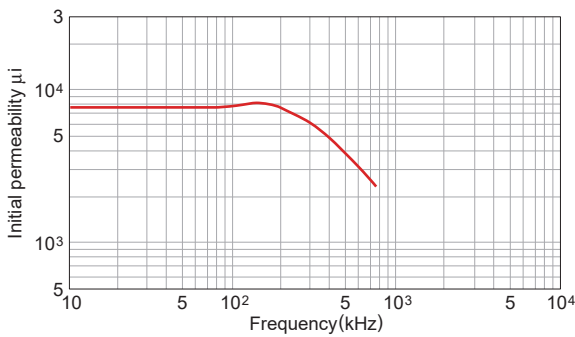

B-H temperature characteristics(Typ.)

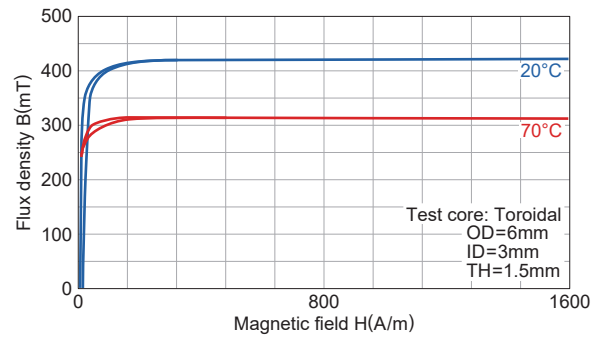

μ_i temperature characteristics(Typ.)

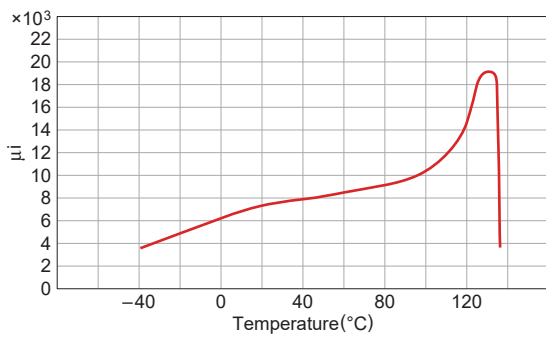

$\tan\delta/\mu_i$ frequency characteristics(Typ.)

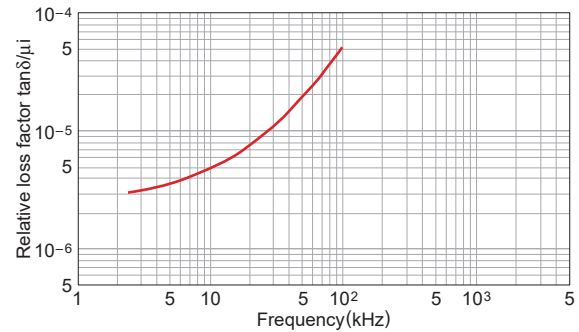

⚠ Please be sure to request delivery specifications that provide further details on the features and specifications of the products for proper and safe use. Please note that the contents may change without any prior notice due to reasons such as upgrading.

Mn-Zn Ferrite for Telecommunication **Material List of H5C2**

MATERIAL CHARACTERISTICS

| Initial permeability | Relative loss factor | Temperature factor of initial permeability | Saturation magnetic flux density* | Remanent flux density* | Coercive force* | Curie temperature | Hysteresis material constant | Disaccommodation factor | Density* | Electrical resistivity* |
|----------------------|----------------------|--|---|---|--|------------------------------|----------------------------------|-------------------------------|--|----------------------------------|
| μ_i | $\tan\delta/\mu_i$ | $\alpha_{\mu ir}$ | B_s (mT) H=1194A/m 25°C | B_r (mT) H=1194A/m 25°C | H_c (A/m) H=1194A/m 25°C | T_c (°C) | ηB $\frac{10^{-6}}{mT}$ | DF $\times 10^{-6}$ | db (kg/m ³) $\times 10^3$ | ρV ($\Omega \cdot m$) |
| 10000±30% | <7.0(10kHz) | -0.5 to 1.5 — -0.5 to 1.5 | 400 | 90 | 7.2 | >120 | <1.4 | <2 | 4.9 | 0.15 |

* Typ.

□ μ_i frequency characteristics(Typ.)

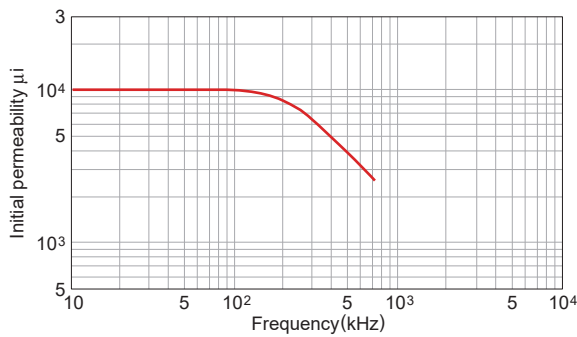

□ μ_i temperature characteristics(Typ.)

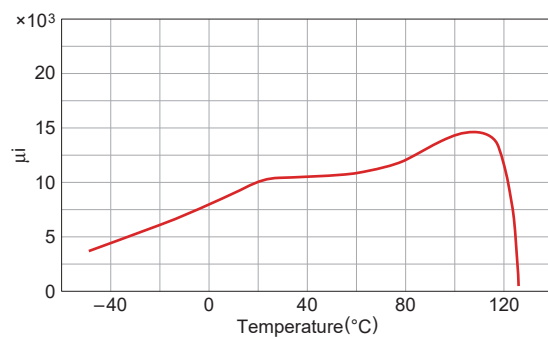

□ B-H temperature characteristics(Typ.)

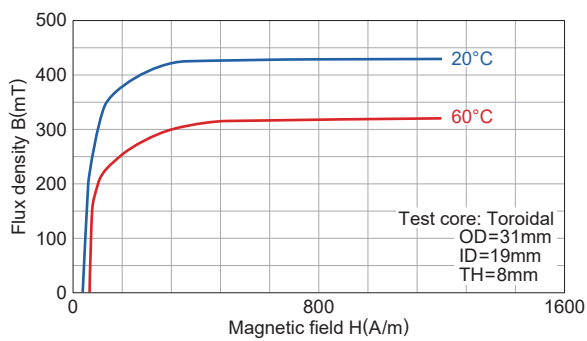

□ $\tan\delta/\mu_i$ frequency characteristics(Typ.)

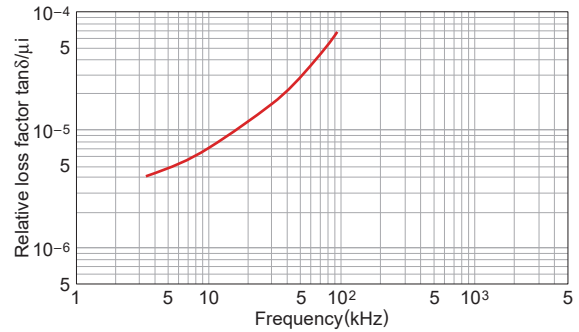

⚠ Please be sure to request delivery specifications that provide further details on the features and specifications of the products for proper and safe use. Please note that the contents may change without any prior notice due to reasons such as upgrading.

Mn-Zn Ferrite for Telecommunication **Material List of H5C3**

MATERIAL CHARACTERISTICS

| Initial permeability | Relative loss factor | Temperature factor of initial permeability | Saturation magnetic flux density* | Remanent flux density* | Coercive force* | Curie temperature | Hysteresis material constant | Disaccommodation factor | Density* | Electrical resistivity* |
|----------------------|----------------------|--|---|---|--|------------------------------|----------------------------------|-------------------------|--|----------------------------------|
| μ_i | $\tan\delta/\mu_i$ | $\alpha_{\mu ir}$ | B_s (mT) H=1194A/m 25°C | B_r (mT) H=1194A/m 25°C | H_c (A/m) H=1194A/m 25°C | T_c (°C) | ηB $\frac{10^{-6}}{mT}$ | DF $\times 10^{-6}$ | db (kg/m ³) $\times 10^3$ | ρ_V ($\Omega \cdot m$) |
| 15000±30% | <7.0(10kHz) | -0.5 to 1.5 — -0.5 to 1.5 | 360 | 105 | 4.4 | >105 | <0.5 | <2 | 4.95 | 0.15 |

* Typ.

□ μ_i frequency characteristics(Typ.)

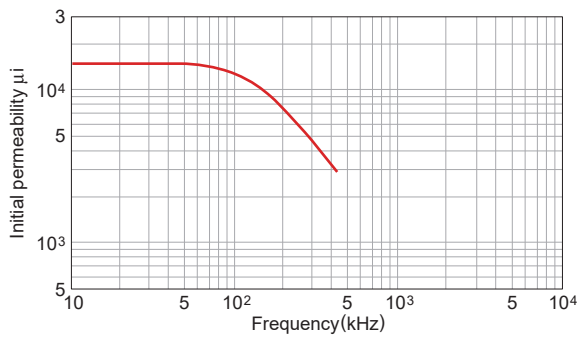

□ μ_i temperature characteristics(Typ.)

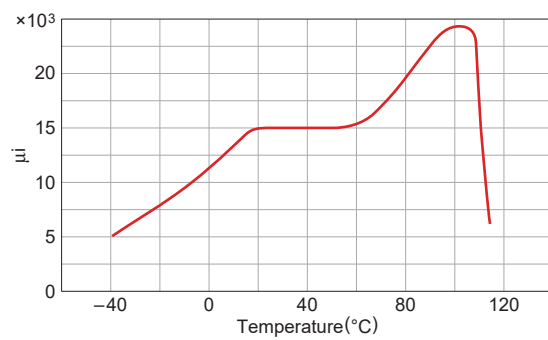

□ B-H temperature characteristics(Typ.)

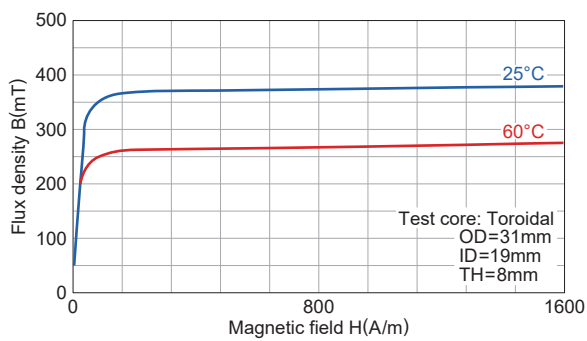

□ $\tan\delta/\mu_i$ frequency characteristics(Typ.)

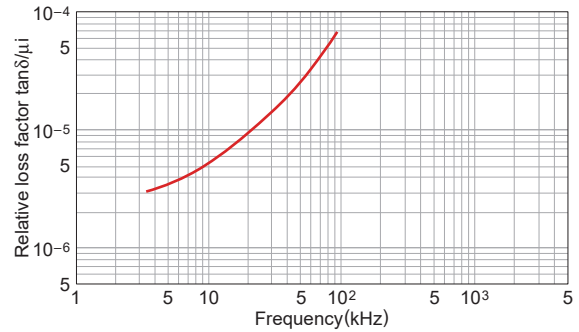

⚠ Please be sure to request delivery specifications that provide further details on the features and specifications of the products for proper and safe use. Please note that the contents may change without any prior notice due to reasons such as upgrading.

Mn-Zn Ferrite for Telecommunication Material List of HP5

MATERIAL CHARACTERISTICS

| Initial permeability | Relative loss factor | Temperature factor of initial permeability | Saturation magnetic flux density* | Remanent flux density* | Coercive force* | Curie temperature | Hysteresis material constant | Disaccommodation factor | Density* | Electrical resistivity* |
|----------------------|----------------------|--|---|---|--|------------------------------|----------------------------------|-------------------------------|--|----------------------------------|
| μ_i | $\tan\delta/\mu_i$ | $\alpha_{\mu ir}$ | B_s (mT) H=1194A/m 25°C | B_r (mT) H=1194A/m 25°C | H_c (A/m) H=1194A/m 25°C | T_c (°C) | ηB $\frac{10^{-6}}{mT}$ | DF $\times 10^{-6}$ | db (kg/m ³) $\times 10^3$ | ρ_V ($\Omega \cdot m$) |
| 5000±20% | <3.5 | — ±12.5% ±12.5% | 400 | 65 | 7.2 | >140 | <0.4 | <3 | 4.8 | 0.15 |

* Typ.

□ μ_i frequency characteristics(Typ.)

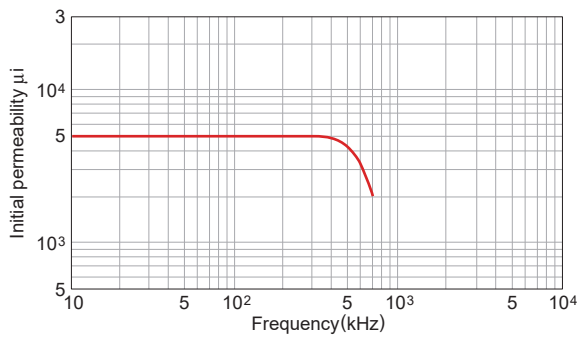

□ μ_i temperature characteristics(Typ.)

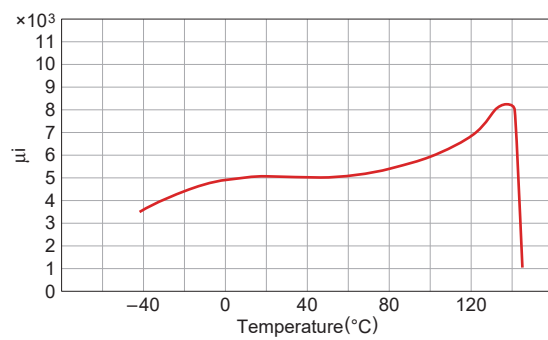

□ B-H temperature characteristics(Typ.)

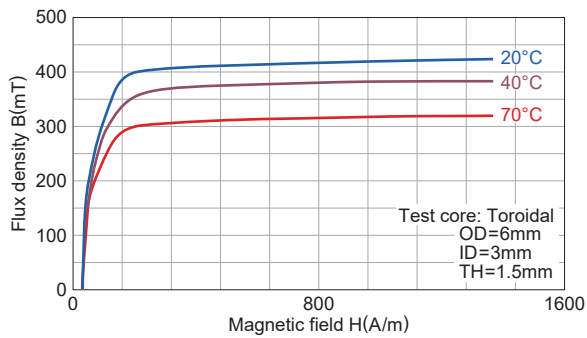

□ $\tan\delta/\mu_i$ frequency characteristics(Typ.)

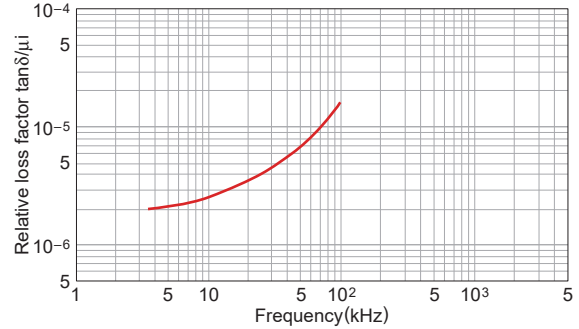

⚠ Please be sure to request delivery specifications that provide further details on the features and specifications of the products for proper and safe use. Please note that the contents may change without any prior notice due to reasons such as upgrading.

Mn-Zn Material List of Large Size Ferrite for High Power

MATERIAL CHARACTERISTICS

| Material | Initial permeability μ_i 23°C | Curie temperature T_c (°C) | Saturation magnetic flux density B_s (mT) H=1194A/m | | Remanent flux density B_r (mT) H=1194A/m | Coercive force H_c (A/m) H=1194A/m | Core loss | | | Electrical resistivity ρ ($\Omega \cdot m$) | Approximate density d_{app} (kg/m ³) $\times 10^3$ | Thermal expansion coefficient α (1/K) $\times 10^{-6}$ | Thermal conductivity κ (W/mK) | Specific heat C_p (J/kg · K) | Bending strength δb_3 (N/m ²) $\times 10^7$ | Young's modulus E (N/m ²) $\times 10^{11}$ | Magnetostriction λ_s $\times 10^{-6}$ |
|----------|---|------------------------------------|--|-------|---|---|-----------|------|-------|--|---|--|--|--------------------------------------|--|---|---|
| | | | 23°C | 100°C | | | 23°C | 23°C | 25kHz | | | | | | | | |
| PE22 | 1800 | >200 | 510 | 410 | 140 | 16 | 79 | 80 | 520 | 3.0 | 4.8 | 12 | 5 | 600 | 9 | 1.2 | -0.6 |
| PC40 | 2300 | >200 | 500 | 380 | 125 | 15 | 64 | 70 | 420 | 6.5 | 4.8 | 12 | 5 | 600 | 9 | 1.2 | -0.6 |

Please be sure to request delivery specifications that provide further details on the features and specifications of the products for proper and safe use. Please note that the contents may change without any prior notice due to reasons such as upgrading.

Mn-Zn Large Size Ferrite for High Power Material List of PE22

MATERIAL CHARACTERISTICS

| Initial permeability μ_i | Curie temperature T_c (°C) | Saturation magnetic flux density B_s (mT) H=1194A/m | | Remanent flux density B_r (mT) H=1194A/m | Coercive force H_c (A/m) H=1194A/m | Core loss | | | Electrical resistivity ρ ($\Omega \cdot m$) | Approximate density d_{app} (kg/m^3) $\times 10^3$ | Thermal expansion coefficient α (1/K) $\times 10^{-6}$ | Thermal conductivity κ (W/mK) | Specific heat C_p (J/kg · K) | Bending strength δb_3 (N/m ²) $\times 10^7$ | Young's modulus E (N/m ²) $\times 10^{11}$ | Magnetostriction λ_s $\times 10^{-6}$ |
|---------------------------------|------------------------------------|--|-------|---|---|-----------|-------|------|--|---|--|--|--------------------------------------|--|---|---|
| | | 23°C | 100°C | | | 23°C | 25kHz | 90°C | | | | | | | | |
| 1800 | >200 | 510 | 410 | 140 | 16 | 79 | 80 | 520 | 3.0 | 4.8 | 12 | 5 | 600 | 9 | 1.2 | -0.6 |

Core loss vs. temperature characteristics(Typ.)

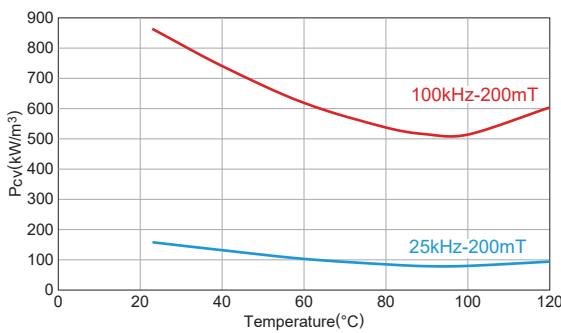

Saturation magnetic flux density vs. temperature characteristics(Typ.)

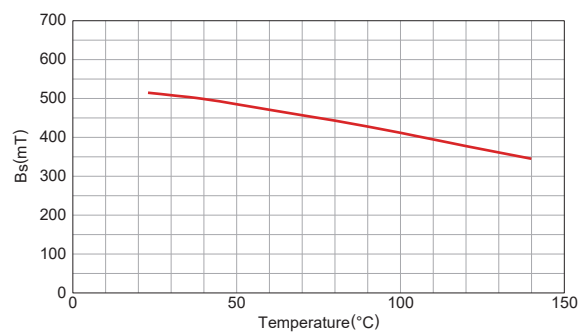

Initial magnetic permeability vs. temperature characteristics(Typ.)

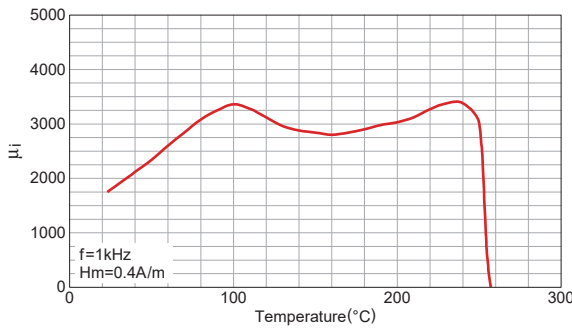

Magnetic permeability vs. frequency characteristics(Typ.)

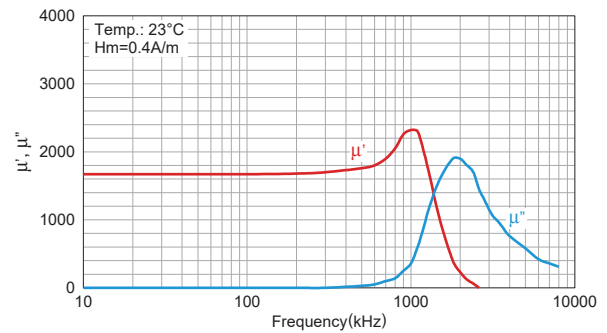

⚠ Please be sure to request delivery specifications that provide further details on the features and specifications of the products for proper and safe use. Please note that the contents may change without any prior notice due to reasons such as upgrading.

Mn-Zn Large Size Ferrite for High Power Material List of PE22

Core loss vs. temperature characteristics

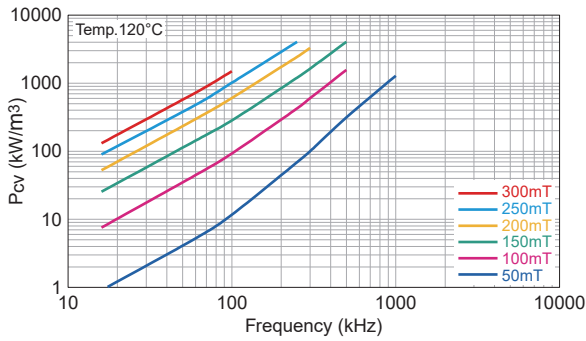
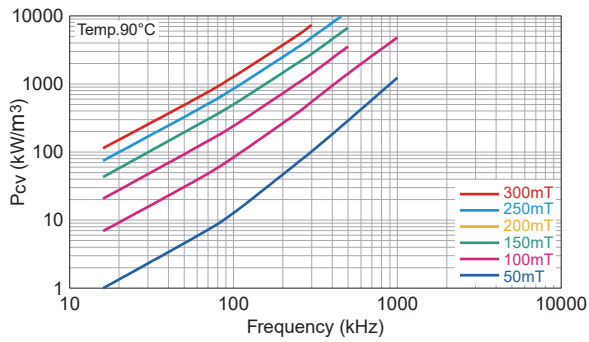
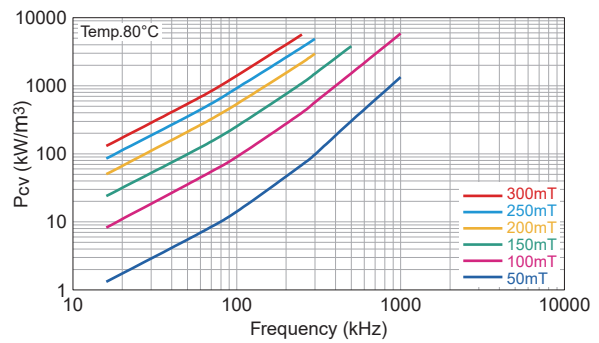
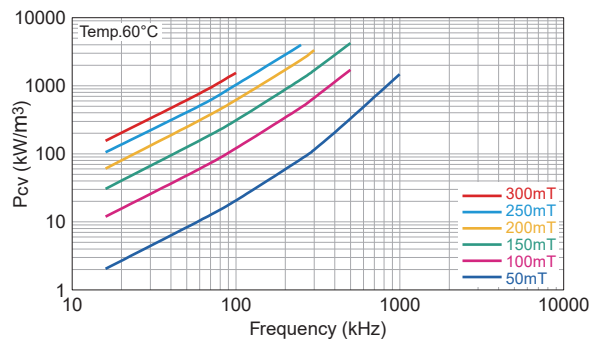
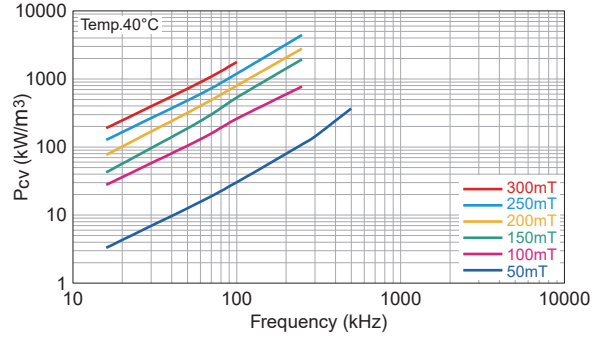
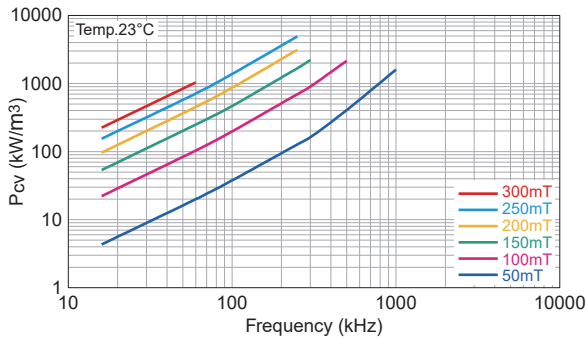

⚠ Please be sure to request delivery specifications that provide further details on the features and specifications of the products for proper and safe use. Please note that the contents may change without any prior notice due to reasons such as upgrading.

Mn-Zn Large Size Ferrite for High Power Material List of PC40

MATERIAL CHARACTERISTICS

| Initial permeability μ_i | Curie temperature T_c (°C) | Saturation magnetic flux density B_s (mT) H=1194A/m | | Remanent flux density B_r (mT) H=1194A/m | Coercive force H_c (A/m) H=1194A/m | Core loss | | | Electrical resistivity ρ ($\Omega \cdot m$) | Approximate density d_{app} (kg/m^3) $\times 10^3$ | Thermal expansion coefficient α (1/K) $\times 10^{-6}$ | Thermal conductivity κ (W/mK) | Specific heat C_p (J/kg · K) | Bending strength δb_3 (N/m ²) $\times 10^7$ | Young's modulus E (N/m ²) $\times 10^{11}$ | Magnetostriction λ_s $\times 10^{-6}$ |
|---------------------------------|------------------------------------|--|-------|---|---|-----------|-------|------|--|---|--|--|--------------------------------------|--|---|---|
| | | 23°C | 100°C | | | 23°C | 25kHz | 90°C | | | | | | | | |
| 2300 | >200 | 500 | 380 | 125 | 15 | 64 | 70 | 420 | 6.5 | 4.8 | 12 | 5 | 600 | 9 | 1.2 | -0.6 |

Core loss vs. temperature characteristics(Typ.)

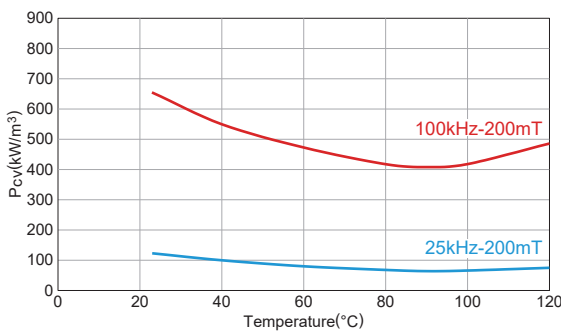

Saturation magnetic flux density vs. temperature characteristics(Typ.)

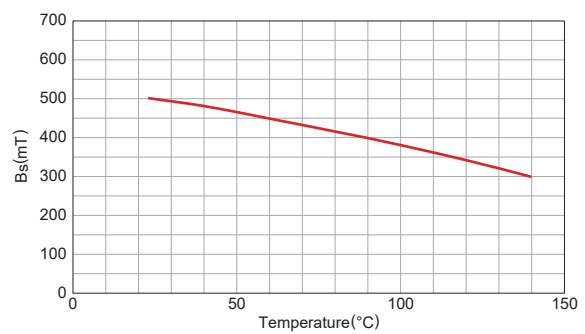

Initial magnetic permeability vs. temperature characteristics(Typ.)

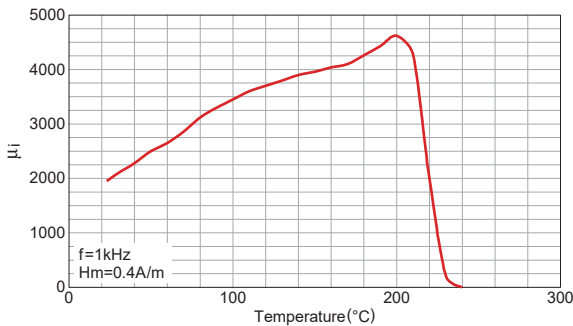

Magnetic permeability vs. frequency characteristics(Typ.)

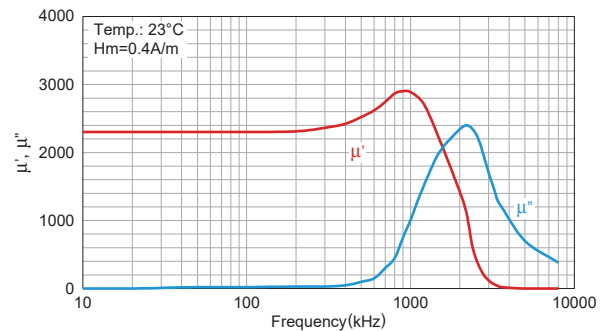

⚠ Please be sure to request delivery specifications that provide further details on the features and specifications of the products for proper and safe use. Please note that the contents may change without any prior notice due to reasons such as upgrading.

Mn-Zn Large Size Ferrite for High Power **Material List of PC40**

Core loss vs. temperature characteristics

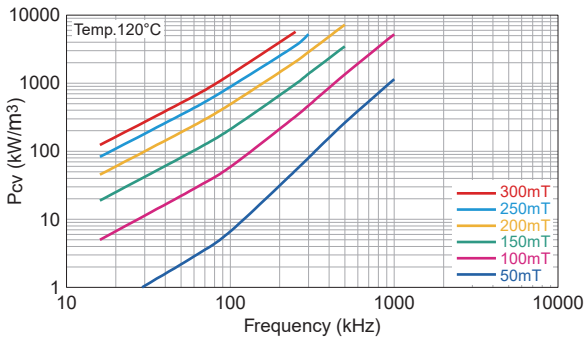
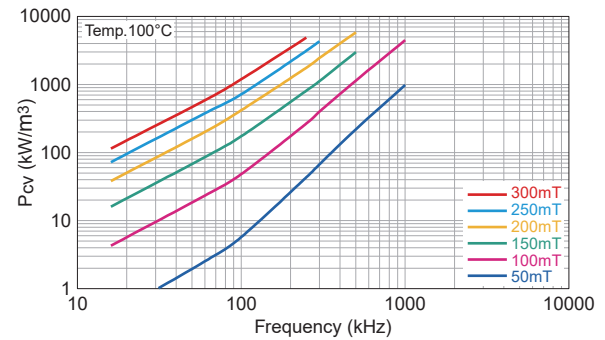
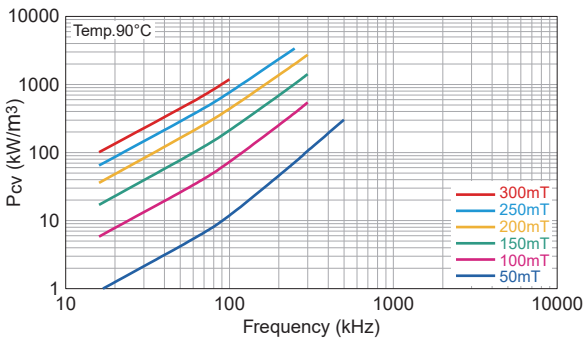
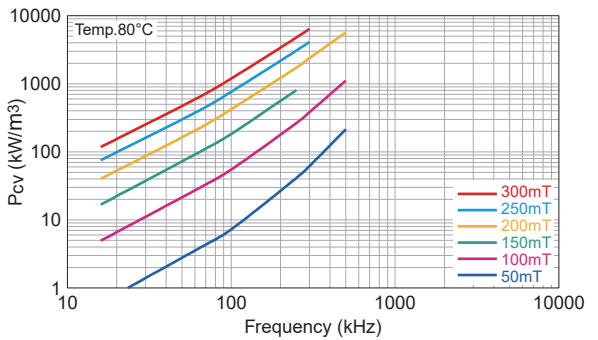
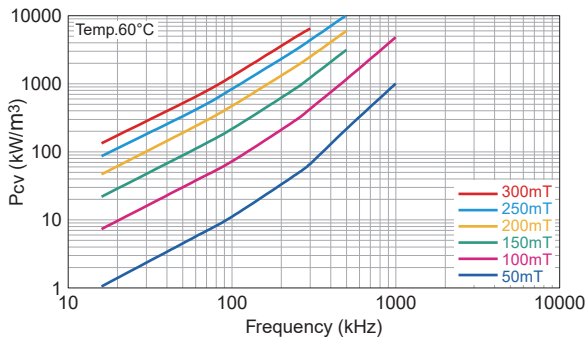
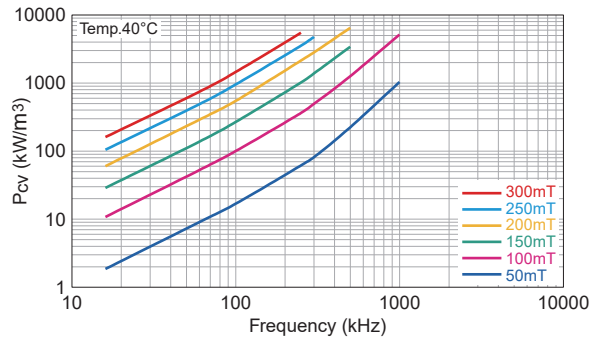
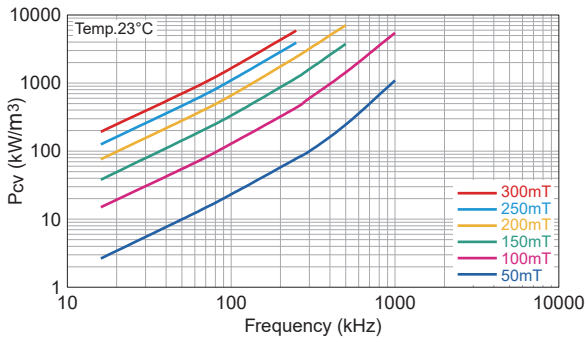

⚠ Please be sure to request delivery specifications that provide further details on the features and specifications of the products for proper and safe use. Please note that the contents may change without any prior notice due to reasons such as upgrading.

Ni-Zn

Material Characteristics

Ferrite for Coil

**REMINDERS FOR USING THESE PRODUCTS**

Please be sure to read this manual thoroughly before using the products.

The products listed on this catalog are intended for use in general electronic equipment (AV equipment, telecommunications equipment, home appliances, amusement equipment, computer equipment, personal equipment, office equipment, measurement equipment, industrial robots) under a normal operation and use condition.

The products are not designed or warranted to meet the requirements of the applications listed below, whose performance and/or quality require a more stringent level of safety or reliability, or whose failure, malfunction or trouble could cause serious damage to society, person or property.

When using the products for specific purposes, please first make confirmations in areas such as safety, reliability, and quality.

Please understand that we are not in a position to be held responsible for any damage or the like caused by any use exceeding the range or conditions of this specification sheet or by any use in the specific applications.

- | | |
|---|--|
| (1) Aerospace/Aviation equipment | (8) Public information-processing equipment |
| (2) Transportation equipment (electric trains, ships, etc.) | (9) Military equipment |
| (3) Medical equipment | (10) Electric heating apparatus, burning equipment |
| (4) Power-generation control equipment | (11) Disaster prevention/crime prevention equipment |
| (5) Atomic energy-related equipment | (12) Safety equipment |
| (6) Seabed equipment | (13) Other applications that are not considered general-purpose applications |
| (7) Transportation control equipment | |

When using this product in general-purpose standard applications, you are kindly requested to take into consideration securing protection circuit/equipment or providing backup circuits, etc to ensure higher safety.

Ni-Zn Material characteristics of Ferrite for Coil

■ For general purpose

| Recommended Material | Practical frequency (MHz) | Initial permeability μ_i | Relative loss factor $\tan\delta/\mu_i$ $\times 10^{-6}$ | Temperature factor of initial permeability $\alpha_{\mu ir}$ $\times 10^{-6}/^{\circ}\text{C}$ [20 to 60°C] | Curie temperature T_c (°C) | Saturation magnetic flux density B_s (mT) | Remanent flux density B_r (mT) | Coercive force H_c (A/m) | Electrical resistivity ρ_v (Ω -m) | Density d_b (kg/m ³) |
|----------------------|---------------------------|------------------------------|---|---|------------------------------|---|----------------------------------|----------------------------|--|------------------------------------|
| L8F | 0.01 to 0.5 | 1500±25% | <10[0.01MHz] <60[0.5MHz] | 1 to 6 | >130 | 320[1.6kA/m] 330[4kA/m] | 130 | 30 | 10 ⁵ | 5.1×10 ³ |
| GT2 | 0.1 to 2 | 250±25% | <60[2MHz] | 9 to 15 | >140 | 310[1.6kA/m] 350[4kA/m] | 160 | 100 | 10 ⁵ | 5.1×10 ³ |
| GT3 | 0.4 to 10 | 120±25% | <100[10MHz] | 8 to 18 | >250 | 400[4kA/m] | 240 | 350 | 10 ⁵ | 5.2×10 ³ |

■ High Bs

| Recommended Material | Practical frequency (MHz) | Initial permeability μ_i | Relative loss factor $\tan\delta/\mu_i$ $\times 10^{-6}$ | Temperature factor of initial permeability $\alpha_{\mu ir}$ $\times 10^{-6}/^{\circ}\text{C}$ [20 to 60°C] | Curie temperature T_c (°C) | Saturation magnetic flux density B_s (mT) | Remanent flux density B_r (mT) | Coercive force H_c (A/m) | Electrical resistivity ρ_v (Ω -m) | Density d_b (kg/m ³) |
|----------------------|---------------------------|------------------------------|---|---|------------------------------|---|----------------------------------|----------------------------|--|------------------------------------|
| L7H | 0.05 to 1 | 800±25% | <12[0.05MHz] <80[1MHz] | 7 to 15 | >180 | 390[4kA/m] | 220 | 16 | 10 ⁵ | 5.1×10 ³ |
| L2H | 0.05 to 2 | 400±25% | <15[0.05MHz] <65[2MHz] | 15 to 25 | >250 | 430[4kA/m] | 240 | 35 | 10 ⁵ | 5.1×10 ³ |
| L20H | 0.05 to 2 | 400±25% | <60[0.05MHz] <80[2MHz] | 13 to 19 | >300 | 480[4kA/m] | 340 | 50 | >10 ⁵ | 5.2×10 ³ |
| L11H | 0.05 to 3 | 300±25% | <30[0.05MHz] <60[3MHz] | 20 to 30 | >250 | 470[4kA/m] | 340 | 60 | >10 ⁵ | 5.2×10 ³ |
| L9H | 0.05 to 3 | 200±25% | <35[0.05MHz] <65[3MHz] | 20 to 30 | >300 | 480[4kA/m] 500[12kA/m] | 280 | 64 | 10 ⁵ | 5.2×10 ³ |

■ Low temperature coefficient

| Recommended Material | Practical frequency (MHz) | Initial permeability μ_i | Relative loss factor $\tan\delta/\mu_i$ $\times 10^{-6}$ | Temperature factor of initial permeability $\alpha_{\mu ir}$ $\times 10^{-6}/^{\circ}\text{C}$ [20 to 60°C] | Curie temperature T_c (°C) | Saturation magnetic flux density B_s (mT) | Remanent flux density B_r (mT) | Coercive force H_c (A/m) | Electrical resistivity ρ_v (Ω -m) | Density d_b (kg/m ³) |
|----------------------|---------------------------|------------------------------|---|---|------------------------------|---|----------------------------------|----------------------------|--|------------------------------------|
| L6 | 0.01 to 0.5 | 1500±25% | <10[0.01MHz] <60[0.5MHz] | 1 to 3 | >100 | 280[1.6kA/m] 290[4kA/m] | 105 | 16 | 10 ⁵ | 5×10 ³ |
| GT1 | 0.1 to 1.5 | 500±25% | <350[1.5MHz] | 0 to 2 | >120 | 300[1.6kA/m] 330[4kA/m] | 90 | 55 | >10 ⁵ | 5.1×10 ³ |
| L6N | 0.1 to 1.5 | 400±25% | <15[0.1MHz] <50[1.5MHz] | -1 to 1 | >180 | 350[4kA/m] | 180 | 120 | >10 ⁵ | 5.2×10 ³ |
| GT8 | 0.1 to 1.5 | 300±25% | <350[1.5MHz] | 0 to 2 | >150 | 260[1.6kA/m] | 105 | 120 | >10 ⁵ | 5.1×10 ³ |
| GT4 | 0.5 to 20 | 70±25% | <350[20MHz] | -1 to 5 | >300 | 360[4kA/m] | 260 | 700 | >10 ⁵ | 5×10 ³ |
| GT10 | 0.5 to 30 | 45±25% | <350[30MHz] | -5 to 5 | >300 | 320[4kA/m] | 250 | 950 | >10 ⁵ | 5×10 ³ |
| GT6 | 10 to 80 | 12±25% | <700[80MHz] | -10 to 10 | >300 | 190[4kA/m] 230[8kA/m] | 160 | 2700 | >10 ⁵ | 4.7×10 ³ |
| GT9 | 10 to 80 | 11±25% | <700[80MHz] | -70 to -30 | >300 | 218[4kA/m] 220[16kA/m] | 130 | 2800 | >10 ⁵ | 4.2×10 ³ |

• All specifications are subject to change without notice.

Stress-insensitive

| Recommended Material | Practical frequency (MHz) | Initial permeability μ_i | Relative loss factor $\tan\delta/\mu_i$ $\times 10^{-6}$ | Temperature factor of initial permeability $\alpha_{\mu ir}$ $\times 10^{-6}/^{\circ}\text{C}$ [20 to 60°C] | Curie temperature T_c (°C) | Saturation magnetic flux density B_s (mT) | Remanent flux density B_r (mT) | Coercive force H_c (A/m) | Electrical resistivity ρ_v ($\Omega \cdot \text{m}$) | Density d_b (kg/m^3) |
|----------------------|---------------------------|------------------------------|---|---|------------------------------|---|----------------------------------|----------------------------|---|--|
| T2F | 0.1 to 1.5 | 400±25% | <25[0.1MHz] <50[1.5MHz] | 2 to 8 | >170 | 420[4kA/m] | 180 | 95 | 10 ⁵ | 5.2×10 ³ |
| T6F | 0.1 to 50 | 18±25% | <300[0.1MHz] <1000[50MHz] | 55 to 65 | >250 | 320[16kA/m] | 57 | 1350 | 10 ⁵ | 5.1×10 ³ |
| T7F | 0.1 to 100 | 8±25% | <700[0.1MHz] <1000[100MHz] | 15 to 25 | >300 | 220[16kA/m] | 130 | 3500 | 10 ⁵ | 5×10 ³ |
| T9F | 0.1 to 1000 | 1 | — | — | — | — | — | — | 10 ⁵ | 5.3×10 ³ |

Low loss

| Recommended Material | Practical frequency (MHz) | Initial permeability μ_i | Relative loss factor $\tan\delta/\mu_i$ $\times 10^{-6}$ | Temperature factor of initial permeability $\alpha_{\mu ir}$ $\times 10^{-6}/^{\circ}\text{C}$ [20 to 60°C] | Curie temperature T_c (°C) | Saturation magnetic flux density B_s (mT) | Remanent flux density B_r (mT) | Coercive force H_c (A/m) | Electrical resistivity ρ_v ($\Omega \cdot \text{m}$) | Density d_b (kg/m^3) |
|----------------------|---------------------------|------------------------------|---|---|------------------------------|---|----------------------------------|----------------------------|---|--|
| L17H | 0.05 to 0.5 | 1200±25% | <10[0.05MHz] <45[0.5MHz] | 9 to 18 | >160 | 375[4kA/m] | 240 | 10 | >10 ⁵ | 5.2×10 ³ |
| L18H | 0.05 to 1.5 | 800±25% | <18[0.05MHz] <140[1.5MHz] | 12 to 18 | >180 | 420[4kA/m] | 280 | 13 | >10 ⁵ | 5.2×10 ³ |
| SY20 | 1 to 5 | 290±25% | <30[1MHz] <600[5MHz] | 15 to 25 | >150 | 330[2kA/m] 345[4kA/m] | 250 | 110 | 10 ⁵ | 5.1×10 ³ |
| SY22 | 5 to 15 | 80 | <230[1MHz] <100[10MHz] | 25 to 45 | >250 | 310[2kA/m] 330[4kA/m] | 200 | 370 | >10 ⁵ | 5.2×10 ³ |

High Q

| Recommended Material | Practical frequency (MHz) | Initial permeability μ_i | Relative loss factor $\tan\delta/\mu_i$ $\times 10^{-6}$ | Temperature factor of initial permeability $\alpha_{\mu ir}$ $\times 10^{-6}/^{\circ}\text{C}$ [20 to 60°C] | Curie temperature T_c (°C) | Saturation magnetic flux density B_s (mT) | Remanent flux density B_r (mT) | Coercive force H_c (A/m) | Electrical resistivity ρ_v ($\Omega \cdot \text{m}$) | Density d_b (kg/m^3) |
|----------------------|---------------------------|------------------------------|---|---|------------------------------|---|----------------------------------|----------------------------|---|--|
| L5 | 0.1 to 1.5 | 750±25% | <15[0.1MHz] <280[1.5MHz] | 1 to 3 | >120 | 310[1.6kA/m] 345[4kA/m] | 105 | 40 | 10 ⁵ | 5×10 ³ |
| GT5 | 3 to 80 | 25±25% | <470[80MHz] | 30 to 70 | >300 | 300[4kA/m] | 220 | 1100 | 10 ⁵ | 5.1×10 ³ |
| GT7 | 10 to 250 | 9±25% | <1500[250MHz] | 100 to 140 | >300 | 180[4kA/m] | 110 | 2900 | 10 ⁵ | 5.1×10 ³ |

• All specifications are subject to change without notice.

Ni-Zn Ferrite for Coil(For general purpose) Material list of L8F

MATERIAL CHARACTERISTICS

| Practical frequency (MHz) | Initial permeability μ_i | Relative loss factor $\tan\delta/\mu_i$ $\times 10^{-6}$ | Temperature factor of initial permeability $\alpha_{\mu i r}$ $\times 10^{-6}/^{\circ}\text{C}$ [20 to 60 $^{\circ}\text{C}$] | Curie temperature T_c ($^{\circ}\text{C}$) | Saturation magnetic flux density B_s (mT) | Remanent flux density B_r (mT) | Coercive force H_c (A/m) | Electrical resistivity ρ_v ($\Omega\text{-m}$) | Density d_b (kg/m^3) |
|------------------------------|---------------------------------|--|---|--|---|--|----------------------------------|---|---|
| 0.01 to 0.5 | 1500 \pm 25% | <10[0.01MHz] <60[0.5MHz] | 1 to 6 | >130 | 320[1.6kA/m] 330[4kA/m] | 130 | 30 | 10 ⁵ | 5.1 \times 10 ³ |

μ_i frequency characteristics(Typ.)

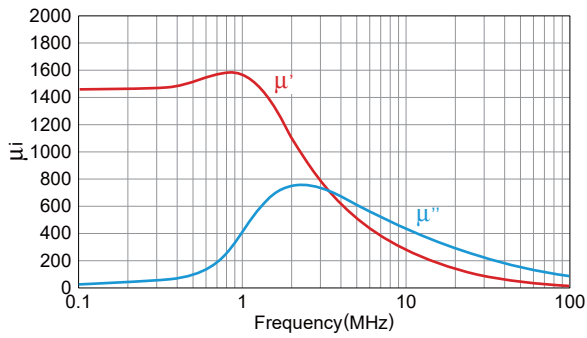

μ_i temperature characteristics(Typ.)

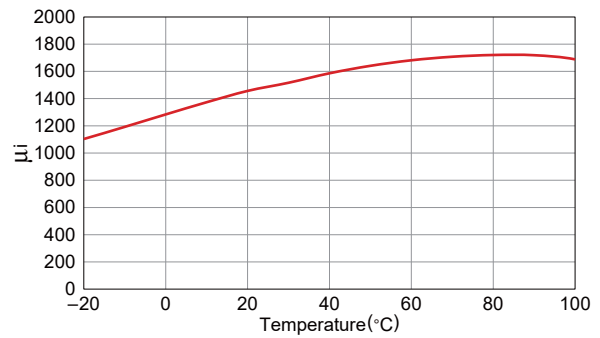

B-H temperature characteristics(Typ.)

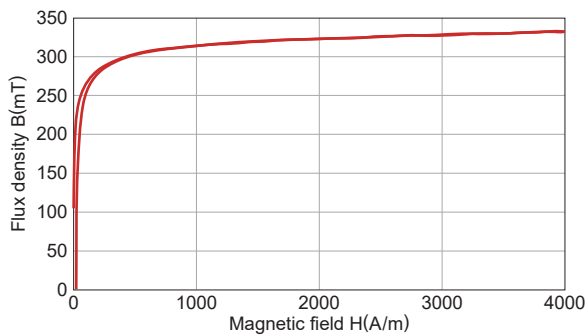

• All specifications are subject to change without notice.

Ni-Zn Ferrite for Coil(For general purpose) Material list of GT2

MATERIAL CHARACTERISTICS

| Practical frequency (MHz) | Initial permeability μ_i | Relative loss factor $\tan\delta/\mu_i$ $\times 10^{-6}$ | Temperature factor of initial permeability $\alpha_{\mu i r}$ $\times 10^{-6}/^{\circ}\text{C}$ [20 to 60 $^{\circ}\text{C}$] | Curie temperature T_c ($^{\circ}\text{C}$) | Saturation magnetic flux density B_s (mT) | Remanent flux density B_r (mT) | Coercive force H_c (A/m) | Electrical resistivity ρ_v ($\Omega\text{-m}$) | Density d_b (kg/m^3) |
|------------------------------|---------------------------------|--|---|--|---|--|----------------------------------|---|--|
| 0.1 to 2 | 250 \pm 25% | <60[2MHz] | 9 to 15 | >140 | 310[1.6kA/m] 350[4kA/m] | 160 | 100 | 10 ⁵ | 5.1 \times 10 ³ |

μ_i frequency characteristics(Typ.)

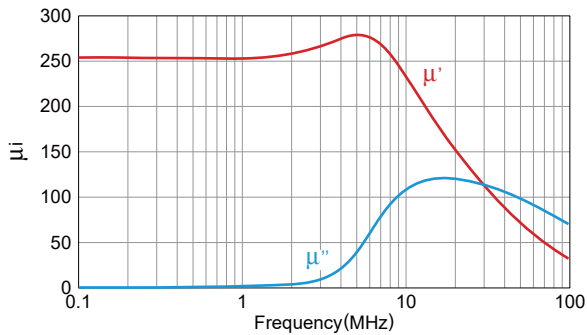

μ_i temperature characteristics(Typ.)

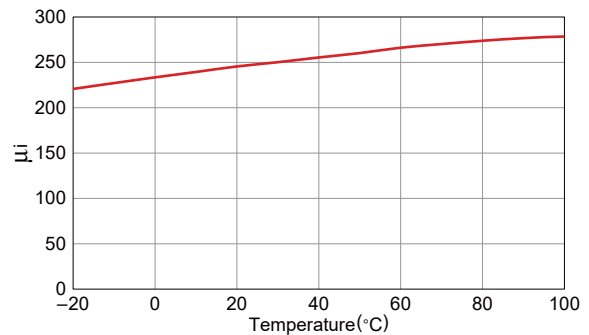

B-H temperature characteristics(Typ.)

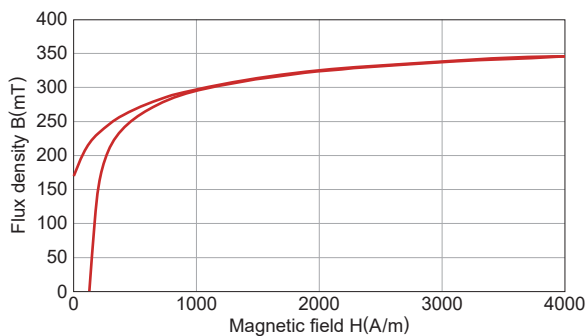

• All specifications are subject to change without notice.

Ni-Zn Ferrite for Coil(For general purpose) Material list of GT3

MATERIAL CHARACTERISTICS

| Practical frequency (MHz) | Initial permeability μ_i | Relative loss factor $\tan\delta/\mu_i$ $\times 10^{-6}$ | Temperature factor of initial permeability $\alpha_{\mu i r}$ $\times 10^{-6}/^{\circ}\text{C}$ [20 to 60 $^{\circ}\text{C}$] | Curie temperature T_c ($^{\circ}\text{C}$) | Saturation magnetic flux density B_s (mT) | Remanent flux density B_r (mT) | Coercive force H_c (A/m) | Electrical resistivity ρ_v ($\Omega \cdot \text{m}$) | Density d_b (kg/m^3) |
|------------------------------|---------------------------------|--|---|--|---|--|----------------------------------|---|--|
| 0.4 to 10 | 120 \pm 25% | <100[10MHz] | 8 to 18 | >250 | 400[4kA/m] | 240 | 350 | 10 ⁵ | 5.2 \times 10 ³ |

μ_i frequency characteristics(Typ.)

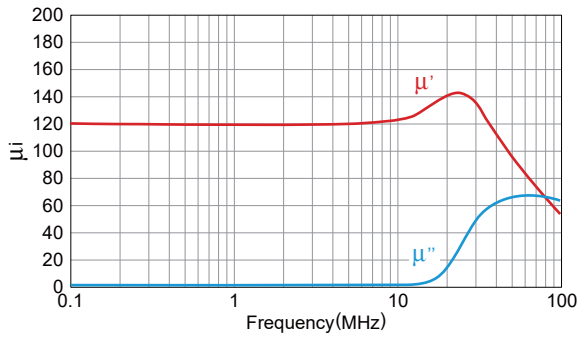

μ_i temperature characteristics(Typ.)

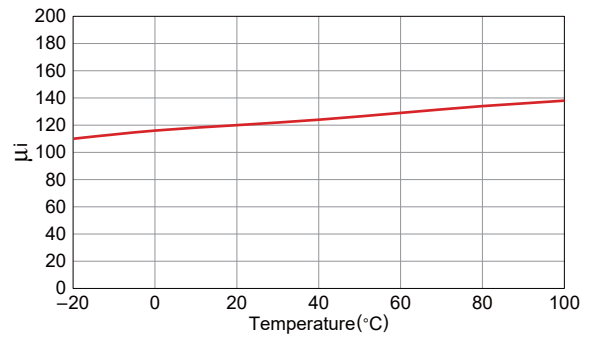

B-H temperature characteristics(Typ.)

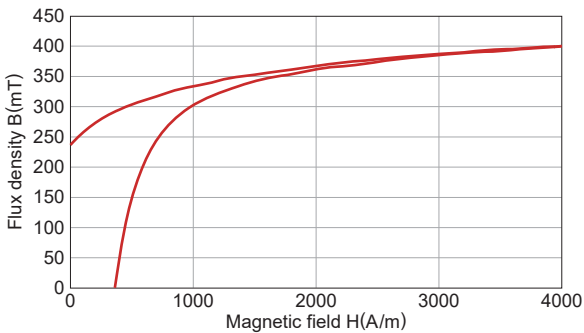

• All specifications are subject to change without notice.

Ni-Zn Ferrite for Coil(High Bs) Material list of L7H

MATERIAL CHARACTERISTICS

| Practical frequency (MHz) | Initial permeability μ_i | Relative loss factor $\tan\delta/\mu_i$ $\times 10^{-6}$ | Temperature factor of initial permeability $\alpha_{\mu i r}$ $\times 10^{-6}/^{\circ}\text{C}$ [20 to 60 $^{\circ}\text{C}$] | Curie temperature T_c ($^{\circ}\text{C}$) | Saturation magnetic flux density B_s (mT) | Remanent flux density B_r (mT) | Coercive force H_c (A/m) | Electrical resistivity ρ_v ($\Omega\cdot\text{m}$) | Density d_b (kg/m^3) |
|------------------------------|---------------------------------|--|---|--|---|--|----------------------------------|---|--|
| 0.05 to 1 | 800 \pm 25% | <12[0.05MHz] <80[1MHz] | 7 to 15 | >180 | 390[4kA/m] | 220 | 16 | 10 ⁵ | 5.1 \times 10 ³ |

μ_i frequency characteristics(Typ.)

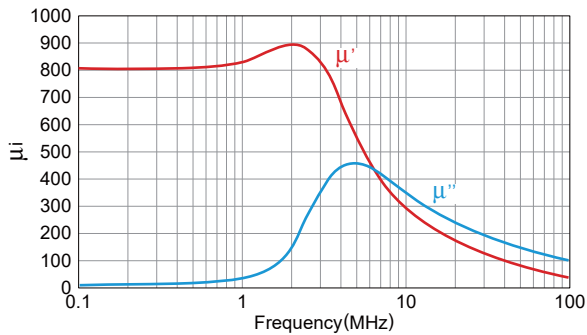

μ_i temperature characteristics(Typ.)

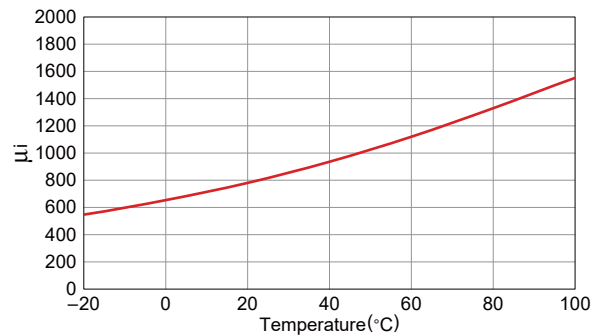

B-H temperature characteristics(Typ.)

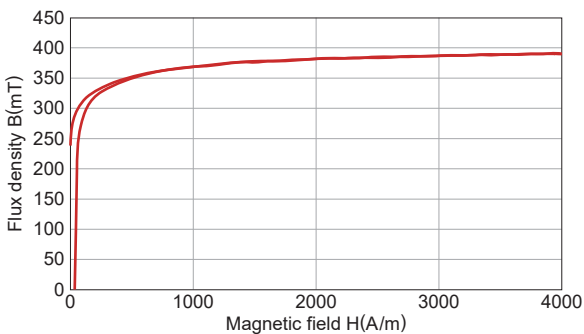

• All specifications are subject to change without notice.

Ni-Zn Ferrite for Coil(High Bs) Material list of L20H

MATERIAL CHARACTERISTICS

| Practical frequency (MHz) | Initial permeability μ_i | Relative loss factor $\tan\delta/\mu_i$ $\times 10^{-6}$ | Temperature factor of initial permeability $\alpha_{\mu i r}$ $\times 10^{-6}/^{\circ}\text{C}$ [20 to 60 $^{\circ}\text{C}$] | Curie temperature T_c ($^{\circ}\text{C}$) | Saturation magnetic flux density B_s (mT) | Remanent flux density B_r (mT) | Coercive force H_c (A/m) | Electrical resistivity ρ_v ($\Omega \cdot \text{m}$) | Density d_b (kg/m^3) |
|------------------------------|---------------------------------|--|---|--|---|--|----------------------------------|---|--|
| 0.05 to 2 | 400 \pm 25% | <60[0.05MHz] <80[2MHz] | 13 to 19 | >300 | 480[4kA/m] | 340 | 50 | >10 ⁵ | 5.2 \times 10 ³ |

μ_i frequency characteristics(Typ.)

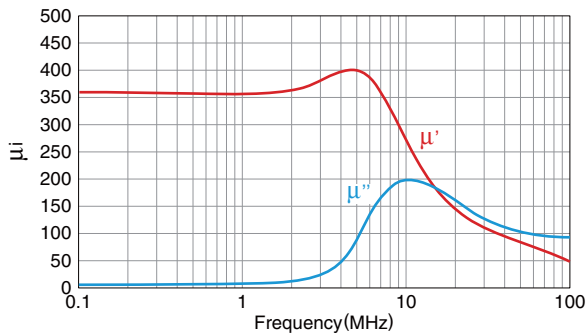

μ_i temperature characteristics(Typ.)

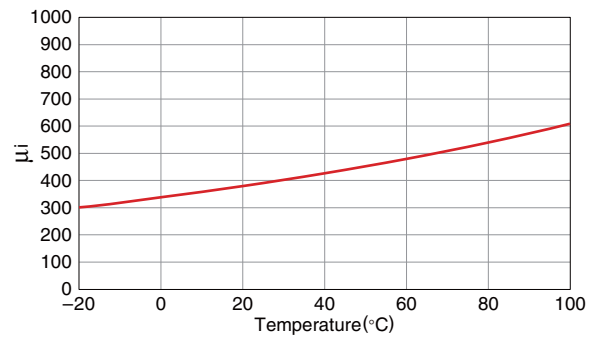

B-H temperature characteristics(Typ.)

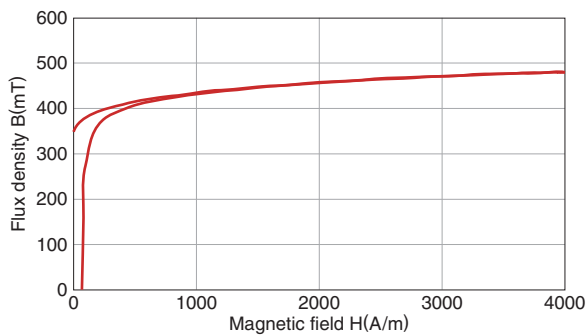

• All specifications are subject to change without notice.

Ni-Zn Ferrite for Coil(High Bs) Material list of L2H

MATERIAL CHARACTERISTICS

| Practical frequency (MHz) | Initial permeability μ_i | Relative loss factor $\tan\delta/\mu_i$ $\times 10^{-6}$ | Temperature factor of initial permeability $\alpha_{\mu i r}$ $\times 10^{-6}/^{\circ}\text{C}$ [20 to 60 $^{\circ}\text{C}$] | Curie temperature T_c ($^{\circ}\text{C}$) | Saturation magnetic flux density B_s (mT) | Remanent flux density B_r (mT) | Coercive force H_c (A/m) | Electrical resistivity ρ_v ($\Omega\text{-m}$) | Density d_b (kg/m^3) |
|------------------------------|---------------------------------|--|---|--|---|--|----------------------------------|---|---|
| 0.05 to 2 | 400 \pm 25% | <15[0.05MHz] <65[2MHz] | 15 to 25 | >250 | 430[4kA/m] | 240 | 35 | 10 ⁵ | 5.1 \times 10 ³ |

μ_i frequency characteristics(Typ.)

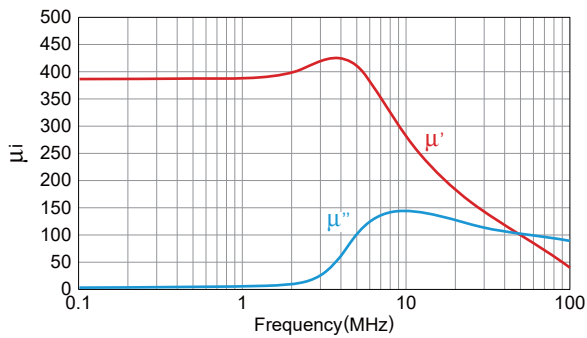

μ_i temperature characteristics(Typ.)

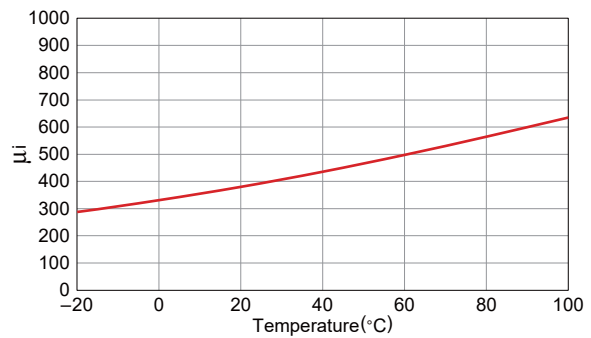

B-H temperature characteristics(Typ.)

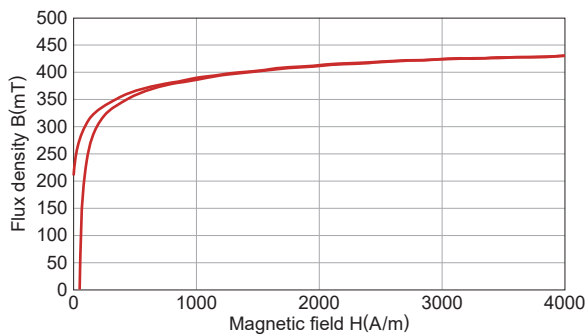

• All specifications are subject to change without notice.

Ni-Zn Ferrite for Coil(High Bs) Material list of L11H

MATERIAL CHARACTERISTICS

| Practical frequency (MHz) | Initial permeability μ_i | Relative loss factor $\tan\delta/\mu_i$ $\times 10^{-6}$ | Temperature factor of initial permeability $\alpha_{\mu i r}$ $\times 10^{-6}/^{\circ}\text{C}$ [20 to 60 $^{\circ}\text{C}$] | Curie temperature T_c ($^{\circ}\text{C}$) | Saturation magnetic flux density B_s (mT) | Remanent flux density B_r (mT) | Coercive force H_c (A/m) | Electrical resistivity ρ_v ($\Omega\cdot\text{m}$) | Density d_b (kg/m^3) |
|------------------------------|---------------------------------|--|---|--|---|--|----------------------------------|---|--|
| 0.05 to 3 | 300 \pm 25% | <30[0.05MHz] <60[3MHz] | 20 to 30 | >250 | 470[4kA/m] | 340 | 60 | >10 ⁵ | 5.2 \times 10 ³ |

μ_i frequency characteristics(Typ.)

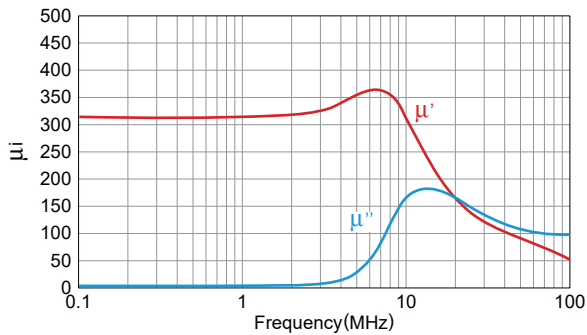

μ_i temperature characteristics(Typ.)

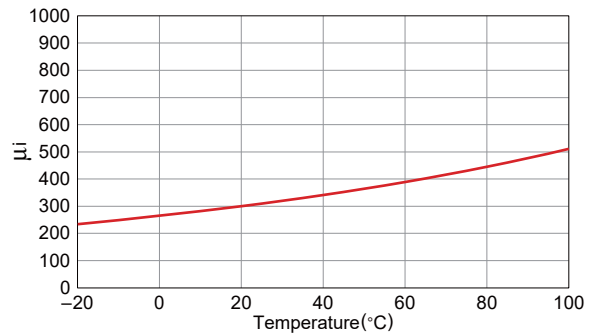

B-H temperature characteristics(Typ.)

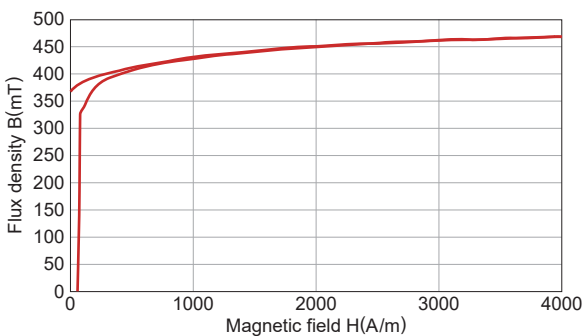

• All specifications are subject to change without notice.

Ni-Zn Ferrite for Coil(High Bs) Material list of L9H

MATERIAL CHARACTERISTICS

| Practical frequency (MHz) | Initial permeability μ_i | Relative loss factor $\tan\delta/\mu_i$ $\times 10^{-6}$ | Temperature factor of initial permeability $\alpha_{\mu i r}$ $\times 10^{-6}/^{\circ}\text{C}$ [20 to 60 $^{\circ}\text{C}$] | Curie temperature T_c ($^{\circ}\text{C}$) | Saturation magnetic flux density B_s (mT) | Remanent flux density B_r (mT) | Coercive force H_c (A/m) | Electrical resistivity ρ_v ($\Omega\text{-m}$) | Density d_b (kg/m^3) |
|------------------------------|---------------------------------|--|---|--|---|--|----------------------------------|---|---|
| 0.05 to 3 | 200 \pm 25% | <35[0.05MHz] <65[3MHz] | 20 to 30 | >300 | 480[4kA/m] 500[12kA/m] | 280 | 64 | 10 ⁵ | 5.2 \times 10 ³ |

μ_i frequency characteristics(Typ.)

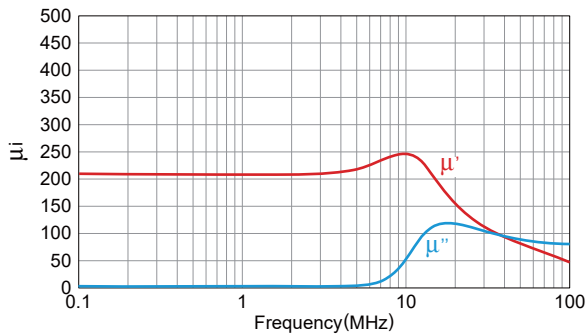

μ_i temperature characteristics(Typ.)

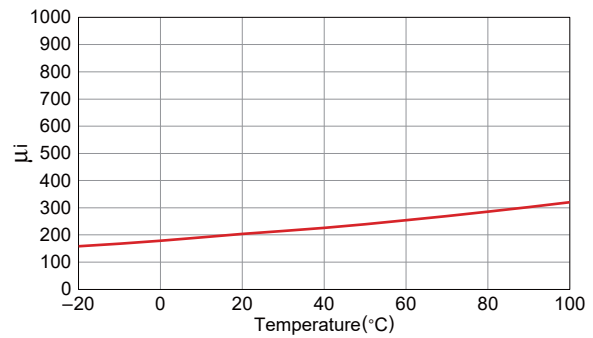

B-H temperature characteristics(Typ.)

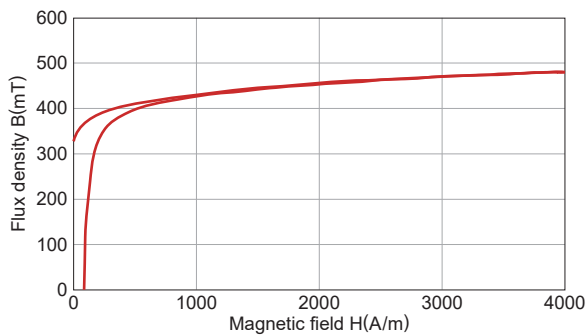

• All specifications are subject to change without notice.

Ni-Zn Ferrite for Coil(Low temperature coefficient) Material list of L6

MATERIAL CHARACTERISTICS

| Practical frequency (MHz) | Initial permeability μ_i | Relative loss factor $\tan\delta/\mu_i$ $\times 10^{-6}$ | Temperature factor of initial permeability $\alpha_{\mu i r}$ $\times 10^{-6}/^{\circ}\text{C}$ [20 to 60 $^{\circ}\text{C}$] | Curie temperature T_c ($^{\circ}\text{C}$) | Saturation magnetic flux density B_s (mT) | Remanent flux density B_r (mT) | Coercive force H_c (A/m) | Electrical resistivity ρ_v ($\Omega \cdot \text{m}$) | Density d_b (kg/m^3) |
|------------------------------|---------------------------------|--|---|--|---|--|----------------------------------|---|--|
| 0.01 to 0.5 | 1500 \pm 25% | <10[0.01MHz] <60[0.5MHz] | 1 to 3 | >100 | 280[1.6kA/m] 290[4kA/m] | 105 | 16 | 10 ⁵ | 5 \times 10 ³ |

μ_i frequency characteristics(Typ.)

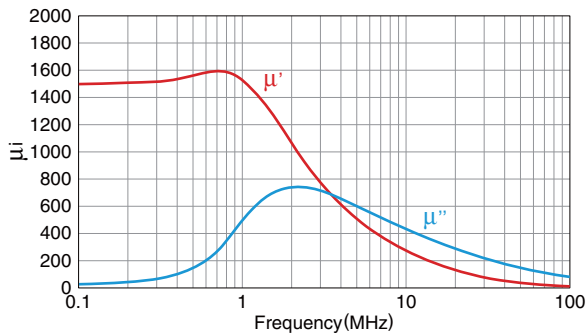

μ_i temperature characteristics(Typ.)

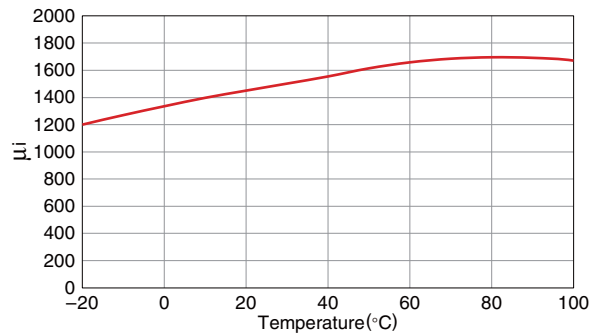

B-H temperature characteristics(Typ.)

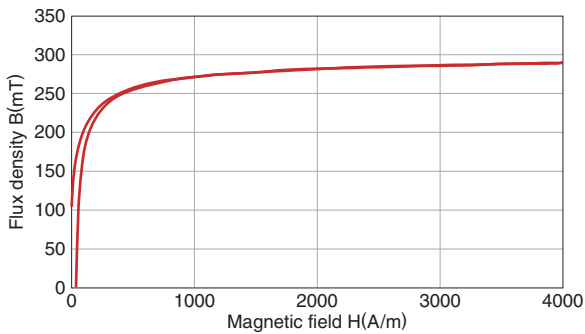

• All specifications are subject to change without notice.

Ni-Zn Ferrite for Coil(Low temperature coefficient) Material list of GT1

MATERIAL CHARACTERISTICS

| Practical frequency (MHz) | Initial permeability μ_i | Relative loss factor $\tan\delta/\mu_i$ $\times 10^{-6}$ | Temperature factor of initial permeability $\alpha_{\mu i r}$ $\times 10^{-6}/^{\circ}\text{C}$ [20 to 60 $^{\circ}\text{C}$] | Curie temperature T_c ($^{\circ}\text{C}$) | Saturation magnetic flux density B_s (mT) | Remanent flux density B_r (mT) | Coercive force H_c (A/m) | Electrical resistivity ρ_v ($\Omega\cdot\text{m}$) | Density d_b (kg/m^3) |
|------------------------------|---------------------------------|--|---|--|---|--|----------------------------------|---|--|
| 0.1 to 1.5 | 500 \pm 25% | <350[1.5MHz] | 0 to 2 | >120 | 300[1.6kA/m] 330[4kA/m] | 90 | 55 | >10 ⁵ | 5.1 \times 10 ³ |

μ_i frequency characteristics(Typ.)

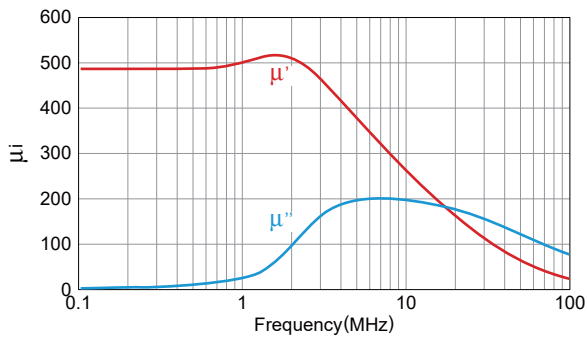

μ_i temperature characteristics(Typ.)

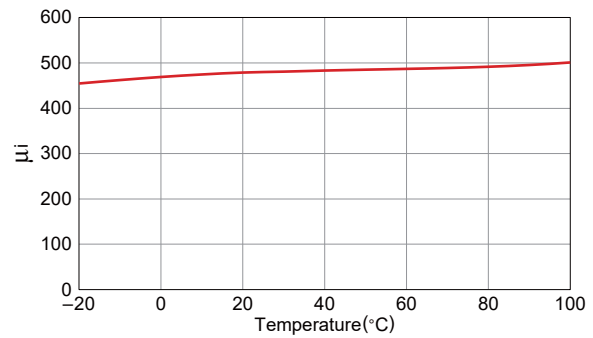

B-H temperature characteristics(Typ.)

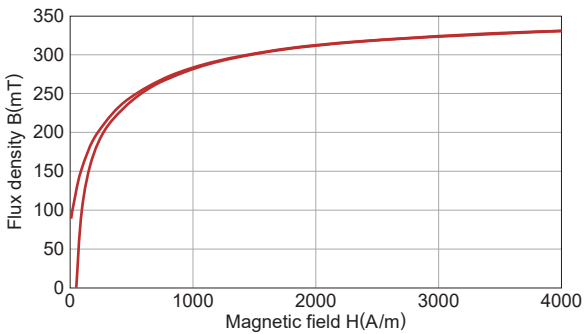

• All specifications are subject to change without notice.

Ni-Zn Ferrite for Coil(Low temperature coefficient) Material list of L6N

MATERIAL CHARACTERISTICS

| Practical frequency (MHz) | Initial permeability μ_i | Relative loss factor $\tan\delta/\mu_i$ $\times 10^{-6}$ | Temperature factor of initial permeability $\alpha_{\mu i r}$ $\times 10^{-6}/^{\circ}\text{C}$ [20 to 60°C] | Curie temperature T_c (°C) | Saturation magnetic flux density B_s (mT) | Remanent flux density B_r (mT) | Coercive force H_c (A/m) | Electrical resistivity ρ_v ($\Omega \cdot \text{m}$) | Density d_b (kg/m^3) |
|------------------------------|---------------------------------|--|---|------------------------------------|---|--|----------------------------------|---|--|
| 0.1 to 1.5 | 400±25% | <15[0.1MHz] <50[1.5MHz] | -1 to 1 | >180 | 350[4kA/m] | 180 | 120 | >10 ⁵ | 5.2×10 ³ |

□ μ_i frequency characteristics(Typ.)

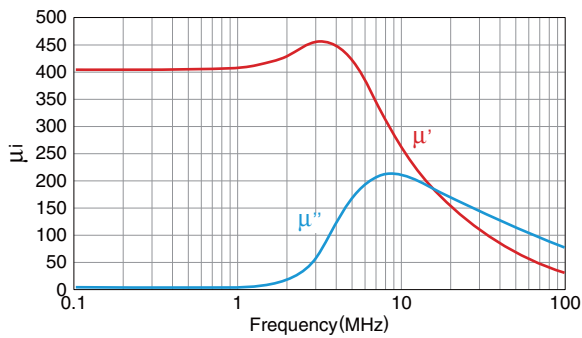

□ μ_i temperature characteristics(Typ.)

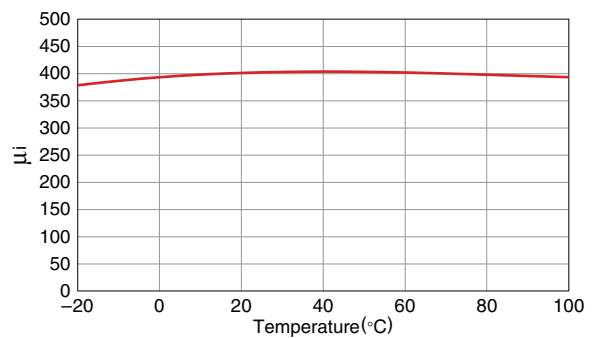

□ B-H temperature characteristics(Typ.)

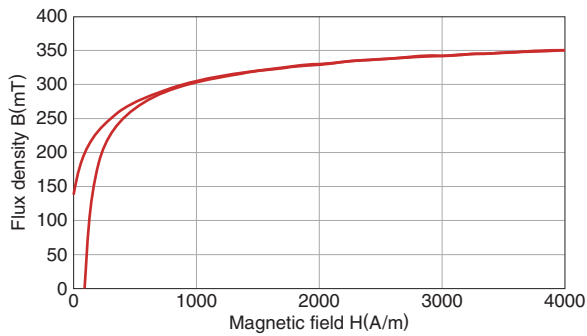

• All specifications are subject to change without notice.

Ni-Zn Ferrite for Coil(Low temperature coefficient) Material list of GT8

MATERIAL CHARACTERISTICS

| Practical frequency (MHz) | Initial permeability μ_i | Relative loss factor $\tan\delta/\mu_i$ $\times 10^{-6}$ | Temperature factor of initial permeability $\alpha_{\mu i r}$ $\times 10^{-6}/^{\circ}\text{C}$ [20 to 60 $^{\circ}\text{C}$] | Curie temperature T_c ($^{\circ}\text{C}$) | Saturation magnetic flux density B_s (mT) | Remanent flux density B_r (mT) | Coercive force H_c (A/m) | Electrical resistivity ρ_v ($\Omega\text{-m}$) | Density d_b (kg/m^3) |
|------------------------------|---------------------------------|--|---|--|---|--|----------------------------------|---|--|
| 0.1 to 1.5 | 300 \pm 25% | <350[1.5MHz] | 0 to 2 | >150 | 260[1.6kA/m] | 105 | 120 | >10 ⁵ | 5.1 \times 10 ³ |

μ_i frequency characteristics(Typ.)

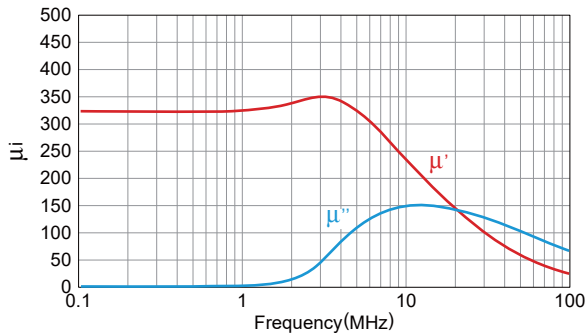

μ_i temperature characteristics(Typ.)

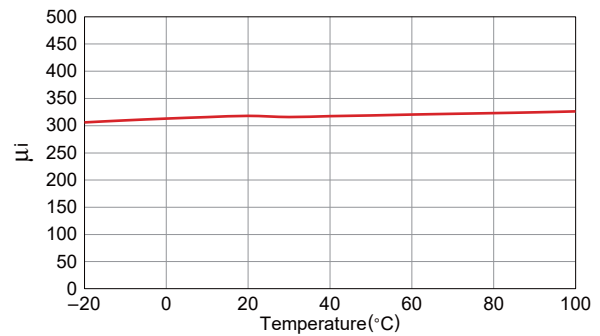

B-H temperature characteristics(Typ.)

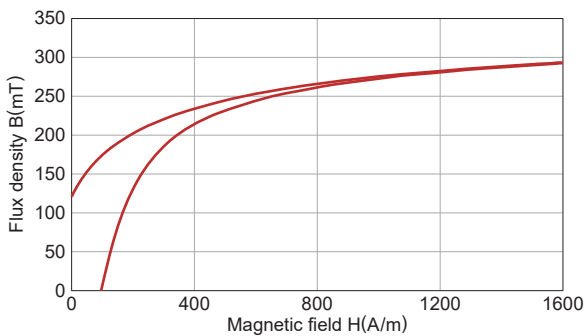

• All specifications are subject to change without notice.

Ni-Zn Ferrite for Coil(Low temperature coefficient) Material list of GT4

MATERIAL CHARACTERISTICS

| Practical frequency (MHz) | Initial permeability μ_i | Relative loss factor $\tan\delta/\mu_i$ $\times 10^{-6}$ | Temperature factor of initial permeability $\alpha_{\mu i r}$ $\times 10^{-6}/^{\circ}\text{C}$ [20 to 60°C] | Curie temperature T_c (°C) | Saturation magnetic flux density B_s (mT) | Remanent flux density B_r (mT) | Coercive force H_c (A/m) | Electrical resistivity ρ_v ($\Omega \cdot m$) | Density d_b (kg/m^3) |
|------------------------------|---------------------------------|--|---|------------------------------------|---|--|----------------------------------|--|--|
| 0.5 to 20 | 70±25% | <350[20MHz] | -1 to 5 | >300 | 360[4kA/m] | 260 | 700 | >10 ⁵ | 5×10 ³ |

□ μ_i frequency characteristics(Typ.)

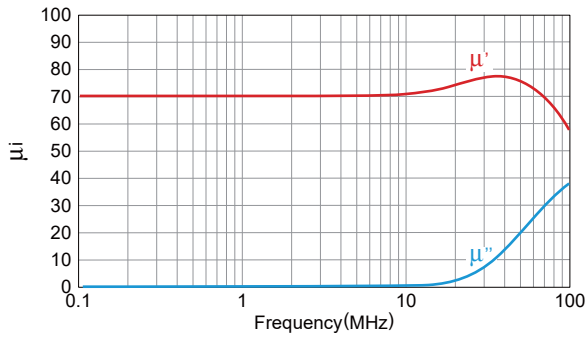

□ μ_i temperature characteristics(Typ.)

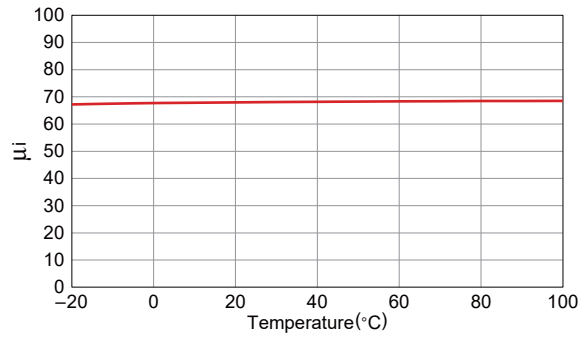

□ B-H temperature characteristics(Typ.)

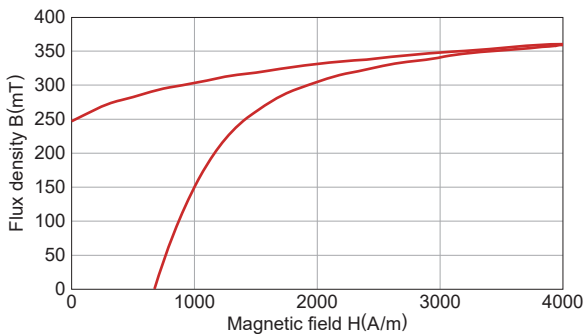

• All specifications are subject to change without notice.

Ni-Zn Ferrite for Coil(Low temperature coefficient) Material list of GT10

MATERIAL CHARACTERISTICS

| Practical frequency (MHz) | Initial permeability μ_i | Relative loss factor $\tan\delta/\mu_i$ $\times 10^{-6}$ | Temperature factor of initial permeability $\alpha_{\mu i r}$ $\times 10^{-6}/^{\circ}\text{C}$ [20 to 60 $^{\circ}\text{C}$] | Curie temperature T_c ($^{\circ}\text{C}$) | Saturation magnetic flux density B_s (mT) | Remanent flux density B_r (mT) | Coercive force H_c (A/m) | Electrical resistivity ρ_v ($\Omega \cdot \text{m}$) | Density d_b (kg/m^3) |
|------------------------------|---------------------------------|--|---|--|---|--|----------------------------------|---|--|
| 0.5 to 30 | 45 \pm 25% | <350[30MHz] | -5 to 5 | >300 | 320[4kA/m] | 250 | 950 | >10 ⁵ | 5 \times 10 ³ |

μ_i frequency characteristics(Typ.)

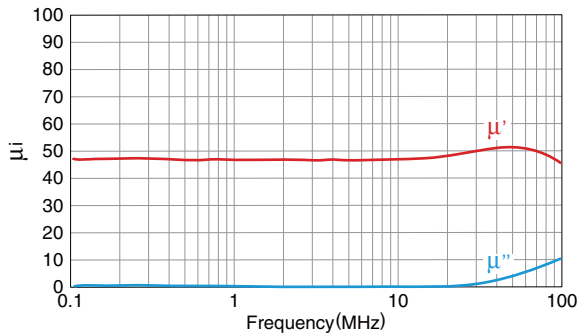

μ_i temperature characteristics(Typ.)

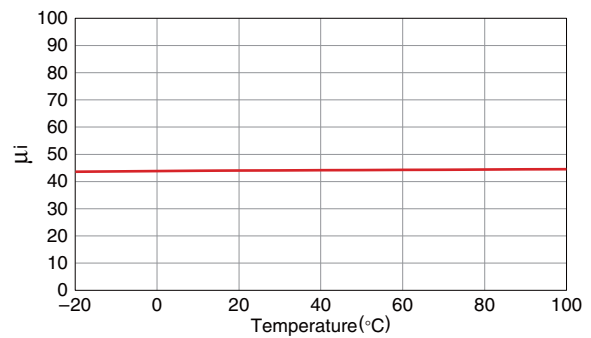

B-H temperature characteristics(Typ.)

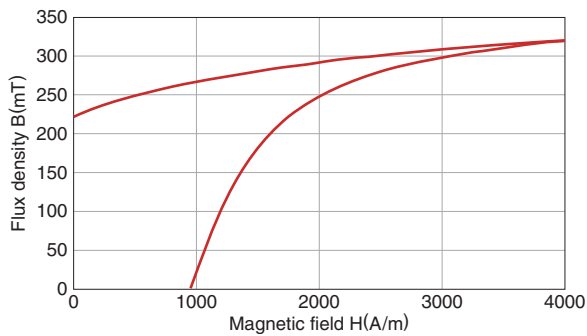

• All specifications are subject to change without notice.

Ni-Zn Ferrite for Coil(Low temperature coefficient) Material list of GT6

MATERIAL CHARACTERISTICS

| Practical frequency (MHz) | Initial permeability μ_i | Relative loss factor $\tan\delta/\mu_i$ $\times 10^{-6}$ | Temperature factor of initial permeability $\alpha_{\mu i r}$ $\times 10^{-6}/^{\circ}\text{C}$ [20 to 60 $^{\circ}\text{C}$] | Curie temperature T_c ($^{\circ}\text{C}$) | Saturation magnetic flux density B_s (mT) | Remanent flux density B_r (mT) | Coercive force H_c (A/m) | Electrical resistivity ρ_v ($\Omega\text{-m}$) | Density d_b (kg/m^3) |
|------------------------------|---------------------------------|--|---|--|---|--|----------------------------------|---|--|
| 10 to 80 | 12 \pm 25% | <700[80MHz] | -10 to 10 | >300 | 190[4kA/m] 230[8kA/m] | 160 | 2700 | >10 ⁵ | 4.7 \times 10 ³ |

μ_i frequency characteristics(Typ.)

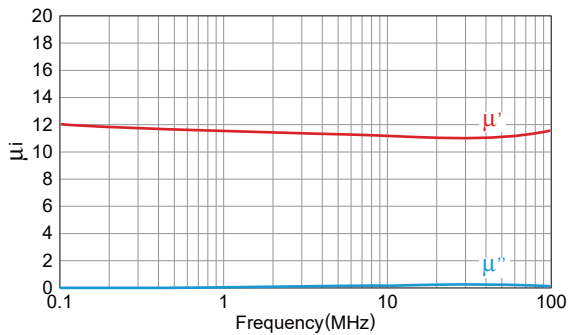

μ_i temperature characteristics(Typ.)

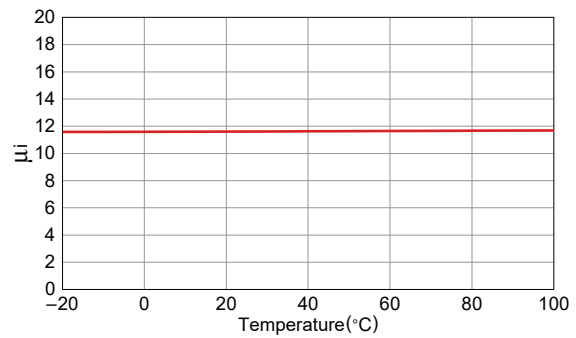

B-H temperature characteristics(Typ.)

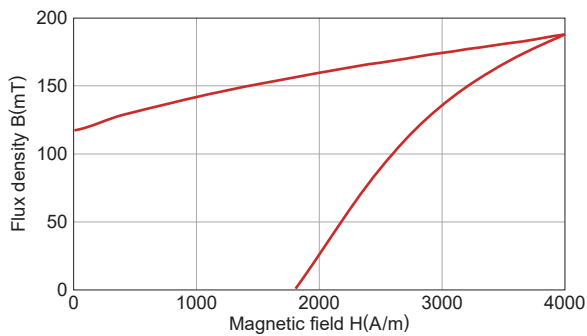

• All specifications are subject to change without notice.

Ni-Zn Ferrite for Coil(Low temperature coefficient) Material list of GT9

MATERIAL CHARACTERISTICS

| Practical frequency (MHz) | Initial permeability μ_i | Relative loss factor $\tan\delta/\mu_i$ $\times 10^{-6}$ | Temperature factor of initial permeability $\alpha_{\mu i r}$ $\times 10^{-6}/^{\circ}\text{C}$ [20 to 60 $^{\circ}\text{C}$] | Curie temperature T_c ($^{\circ}\text{C}$) | Saturation magnetic flux density B_s (mT) | Remanent flux density B_r (mT) | Coercive force H_c (A/m) | Electrical resistivity ρ_v ($\Omega\text{-m}$) | Density d_b (kg/m^3) |
|------------------------------|---------------------------------|--|---|--|---|--|----------------------------------|---|--|
| 10 to 80 | 11 \pm 25% | <700[80MHz] | -70 to -30 | >300 | 218[4kA/m] 220[16kA/m] | 130 | 2800 | >10 ⁵ | 4.2 \times 10 ³ |

μ_i frequency characteristics(Typ.)

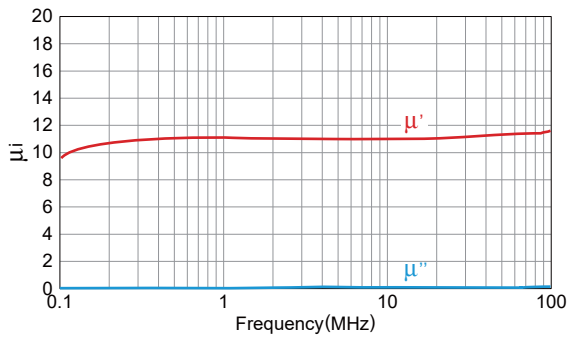

μ_i temperature characteristics(Typ.)

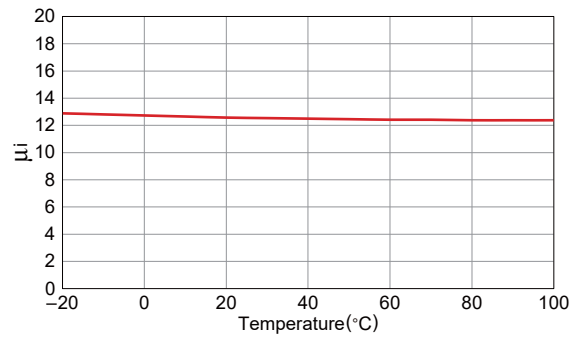

B-H temperature characteristics(Typ.)

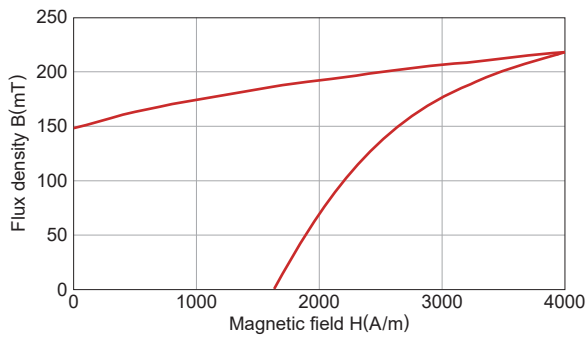

• All specifications are subject to change without notice.

Ni-Zn Ferrite for Coil(Stress-insensitive) Material list of T2F

MATERIAL CHARACTERISTICS

| Practical frequency (MHz) | Initial permeability μ_i | Relative loss factor $\tan\delta/\mu_i$ $\times 10^{-6}$ | Temperature factor of initial permeability $\alpha_{\mu i r}$ $\times 10^{-6}/^{\circ}\text{C}$ [20 to 60 $^{\circ}\text{C}$] | Curie temperature T_c ($^{\circ}\text{C}$) | Saturation magnetic flux density B_s (mT) | Remanent flux density B_r (mT) | Coercive force H_c (A/m) | Electrical resistivity ρ_v ($\Omega \cdot \text{m}$) | Density d_b (kg/m^3) |
|------------------------------|---------------------------------|--|---|--|---|--|----------------------------------|---|--|
| 0.1 to 1.5 | 400 \pm 25% | <25[0.1MHz] <50[1.5MHz] | 2 to 8 | >170 | 420[4kA/m] | 180 | 95 | 10 ⁵ | 5.2 \times 10 ³ |

μ_i frequency characteristics(Typ.)

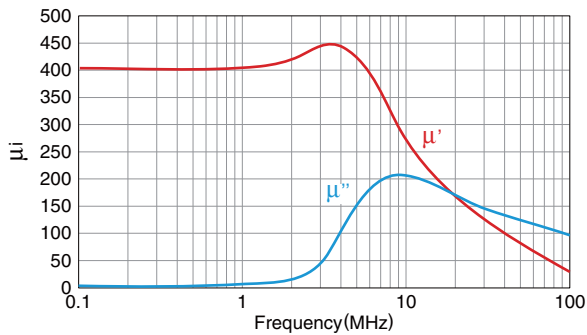

μ_i temperature characteristics(Typ.)

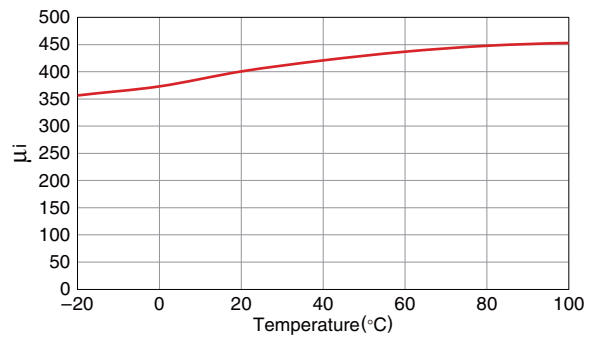

B-H temperature characteristics(Typ.)

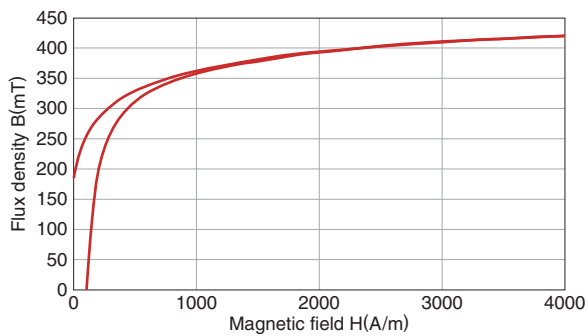

• All specifications are subject to change without notice.

Ni-Zn Ferrite for Coil(Stress-insensitive) Material list of T6F

MATERIAL CHARACTERISTICS

| Practical frequency (MHz) | Initial permeability μ_i | Relative loss factor $\tan\delta/\mu_i$ $\times 10^{-6}$ | Temperature factor of initial permeability $\alpha_{\mu i r}$ $\times 10^{-6}/^{\circ}\text{C}$ [20 to 60 $^{\circ}\text{C}$] | Curie temperature T_c ($^{\circ}\text{C}$) | Saturation magnetic flux density B_s (mT) | Remanent flux density B_r (mT) | Coercive force H_c (A/m) | Electrical resistivity ρ_v ($\Omega \cdot \text{m}$) | Density d_b (kg/m^3) |
|------------------------------|---------------------------------|--|---|--|---|--|----------------------------------|---|--|
| 0.1 to 50 | 18 \pm 25% | <300[0.1MHz] <1000[50MHz] | 55 to 65 | >250 | 320[16kA/m] | 57 | 1350 | 10 ⁵ | 5.1 \times 10 ³ |

μ_i frequency characteristics(Typ.)

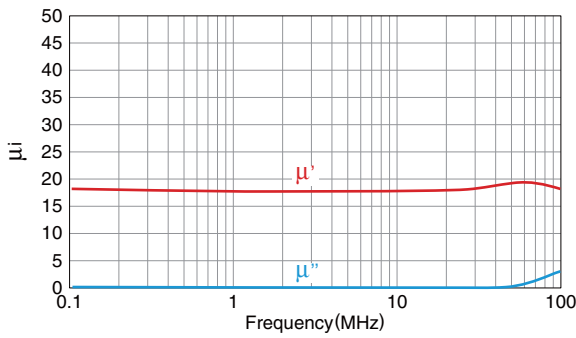

μ_i temperature characteristics(Typ.)

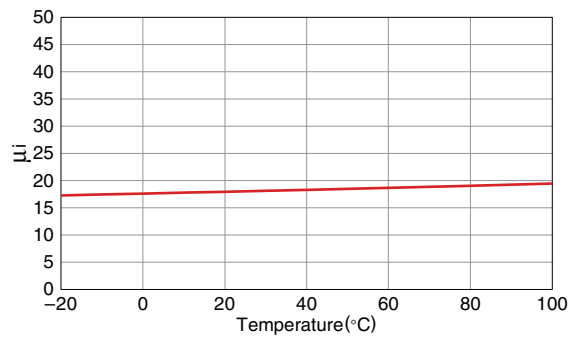

B-H temperature characteristics(Typ.)

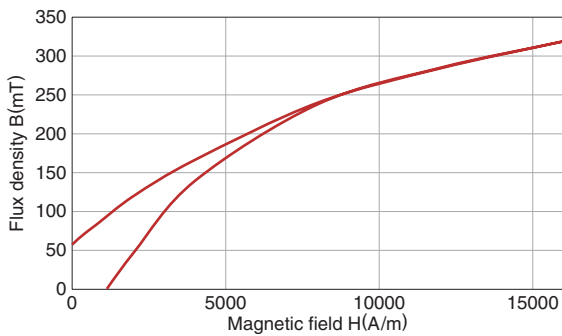

• All specifications are subject to change without notice.

Ni-Zn Ferrite for Coil(Stress-insensitive) Material list of T7F

MATERIAL CHARACTERISTICS

| Practical frequency (MHz) | Initial permeability μ_i | Relative loss factor $\tan\delta/\mu_i$ $\times 10^{-6}$ | Temperature factor of initial permeability $\alpha_{\mu i r}$ $\times 10^{-6}/^{\circ}\text{C}$ [20 to 60 $^{\circ}\text{C}$] | Curie temperature T_c ($^{\circ}\text{C}$) | Saturation magnetic flux density B_s (mT) | Remanent flux density B_r (mT) | Coercive force H_c (A/m) | Electrical resistivity ρ_v ($\Omega \cdot \text{m}$) | Density d_b (kg/m^3) |
|------------------------------|---------------------------------|--|---|--|---|--|----------------------------------|---|--|
| 0.1 to 100 | 8 \pm 25% | <700[0.1MHz] <1000[100MHz] | 15 to 25 | >300 | 220[16kA/m] | 130 | 3500 | 10 ⁵ | 5 \times 10 ³ |

μ_i frequency characteristics(Typ.)

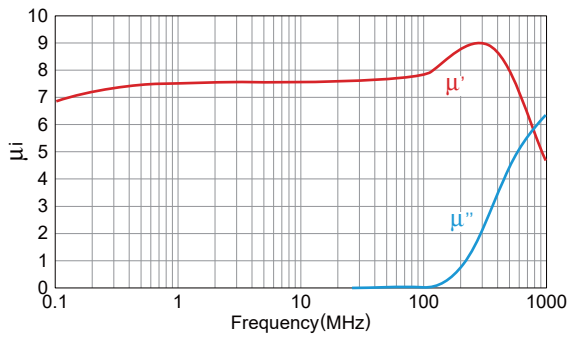

μ_i temperature characteristics(Typ.)

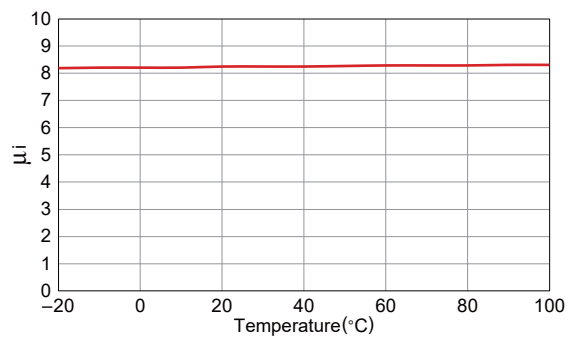

B-H temperature characteristics(Typ.)

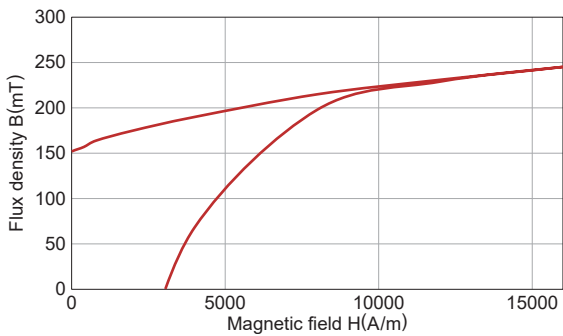

• All specifications are subject to change without notice.

Ni-Zn Ferrite for Coil(Stress-insensitive) Material list of T9F

MATERIAL CHARACTERISTICS

| Practical frequency (MHz) | Initial permeability μ_i | Relative loss factor $\tan\delta/\mu_i$ $\times 10^{-6}$ | Temperature factor of initial permeability $\alpha_{\mu i r}$ $\times 10^{-6}/^{\circ}\text{C}$ [20 to 60 $^{\circ}\text{C}$] | Curie temperature T_c ($^{\circ}\text{C}$) | Saturation magnetic flux density B_s (mT) | Remanent flux density B_r (mT) | Coercive force H_c (A/m) | Electrical resistivity ρ_v ($\Omega\text{-m}$) | Density d_b (kg/m^3) |
|------------------------------|---------------------------------|--|---|--|---|--|----------------------------------|---|---|
| 0.1 to 1000 | 1 | — | — | — | — | — | — | 10^5 | 5.3×10^3 |

μ_i frequency characteristics(Typ.)

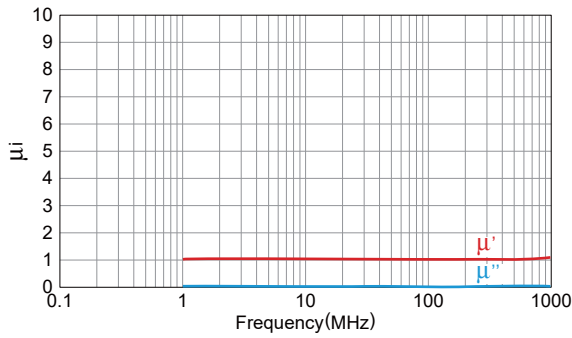

• All specifications are subject to change without notice.

Ni-Zn Ferrite for Coil(Low loss) Material list of L17H

MATERIAL CHARACTERISTICS

| Practical frequency (MHz) | Initial permeability μ_i | Relative loss factor $\tan\delta/\mu_i$ $\times 10^{-6}$ | Temperature factor of initial permeability $\alpha_{\mu i r}$ $\times 10^{-6}/^{\circ}\text{C}$ [20 to 60 $^{\circ}\text{C}$] | Curie temperature T_c ($^{\circ}\text{C}$) | Saturation magnetic flux density B_s (mT) | Remanent flux density B_r (mT) | Coercive force H_c (A/m) | Electrical resistivity ρ_v ($\Omega\cdot\text{m}$) | Density d_b (kg/m^3) |
|------------------------------|---------------------------------|--|---|--|---|--|----------------------------------|---|--|
| 0.05 to 0.5 | 1200 \pm 25% | <10[0.05MHz] <45[0.5MHz] | 9 to 18 | >160 | 375[4kA/m] | 240 | 10 | >10 ⁵ | 5.2 \times 10 ³ |

μ_i frequency characteristics(Typ.)

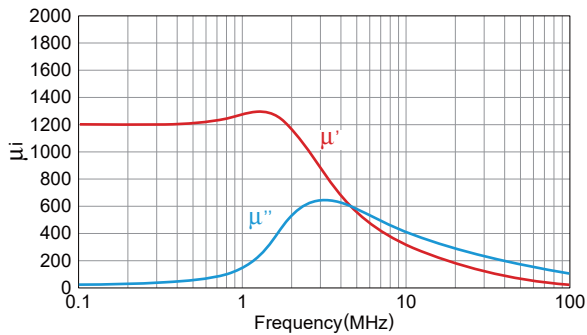

μ_i temperature characteristics(Typ.)

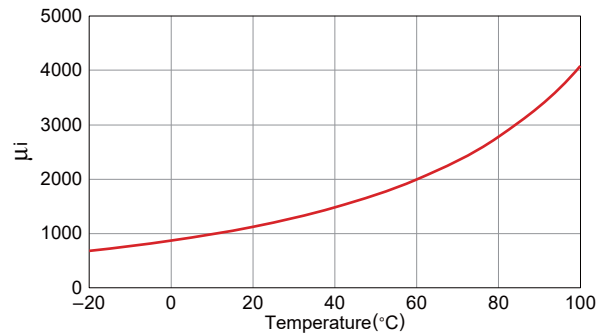

B-H temperature characteristics(Typ.)

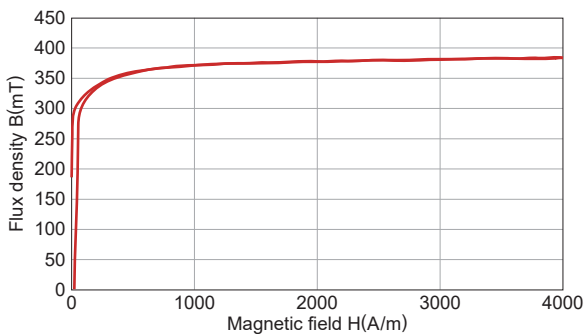

Core Loss(Typ.)

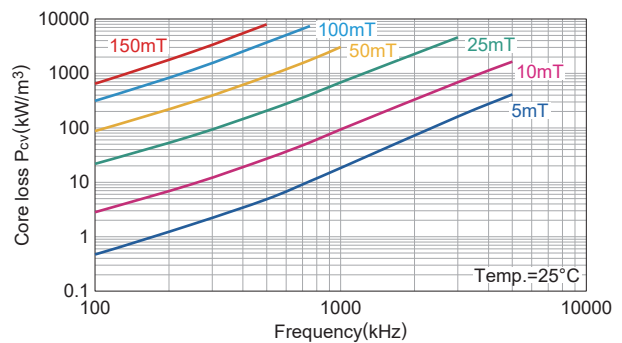

• All specifications are subject to change without notice.

Ni-Zn Ferrite for Coil(Low loss) Material list of L18H

MATERIAL CHARACTERISTICS

| Practical frequency (MHz) | Initial permeability μ_i | Relative loss factor $\tan\delta/\mu_i$ $\times 10^{-6}$ | Temperature factor of initial permeability $\alpha_{\mu i r}$ $\times 10^{-6}/^{\circ}\text{C}$ [20 to 60 $^{\circ}\text{C}$] | Curie temperature T_c ($^{\circ}\text{C}$) | Saturation magnetic flux density B_s (mT) | Remanent flux density B_r (mT) | Coercive force H_c (A/m) | Electrical resistivity ρ_v ($\Omega\text{-m}$) | Density d_b (kg/m^3) |
|------------------------------|---------------------------------|--|---|--|---|--|----------------------------------|---|---|
| 0.05 to 1.5 | 800 \pm 25% | <18[0.05MHz] <140[1.5MHz] | 12 to 18 | >180 | 420[4kA/m] | 280 | 13 | >10 ⁵ | 5.2 \times 10 ³ |

μ_i frequency characteristics(Typ.)

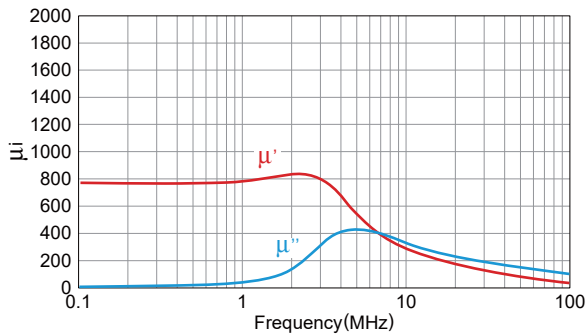

μ_i temperature characteristics(Typ.)

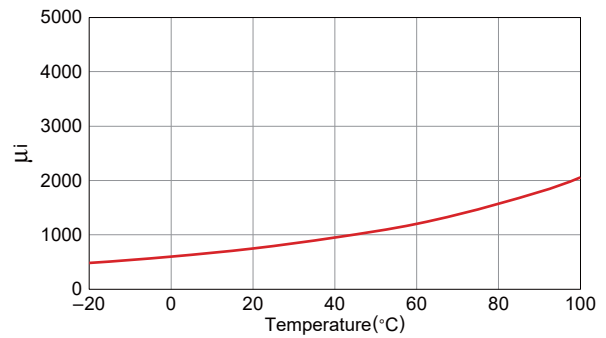

B-H temperature characteristics(Typ.)

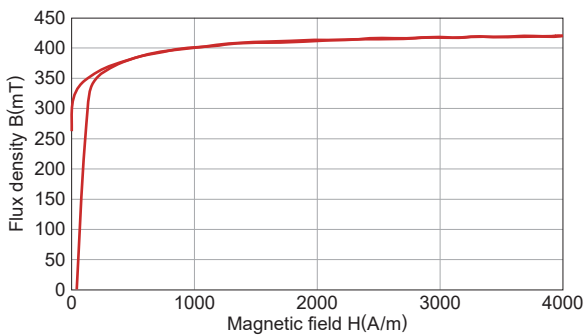

Core Loss(Typ.)

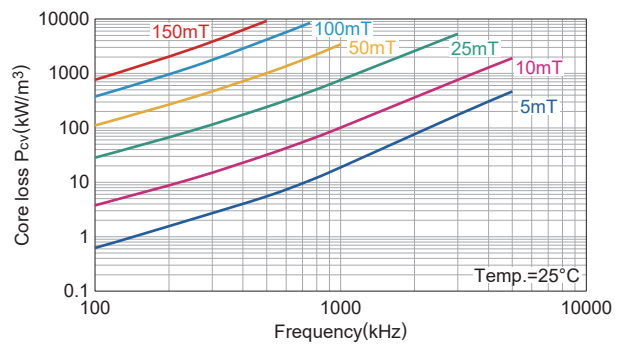

• All specifications are subject to change without notice.

Ni-Zn Ferrite for Coil(Low loss) Material list of SY20

MATERIAL CHARACTERISTICS

| Practical frequency (MHz) | Initial permeability μ_i | Relative loss factor $\tan\delta/\mu_i$ $\times 10^{-6}$ | Temperature factor of initial permeability $\alpha_{\mu i}$ $\times 10^{-6}/^{\circ}\text{C}$ [20 to 60 $^{\circ}\text{C}$] | Curie temperature T_c ($^{\circ}\text{C}$) | Saturation magnetic flux density B_s (mT) | Remanent flux density B_r (mT) | Coercive force H_c (A/m) | Electrical resistivity ρ_v ($\Omega \cdot \text{m}$) | Density d_b (kg/m^3) |
|------------------------------|---------------------------------|--|---|--|---|--|----------------------------------|---|--|
| 1 to 5 | 290 \pm 25% | <30[1MHz] <600[5MHz] | 15 to 25 | >150 | 330[2kA/m] 345[4kA/m] | 250 | 110 | 10 ⁵ | 5.1 \times 10 ³ |

μ_i frequency characteristics(Typ.)

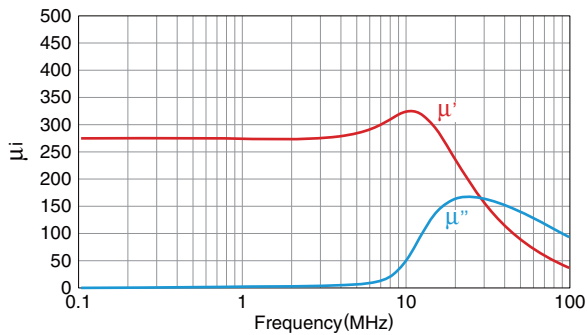

μ_i temperature characteristics(Typ.)

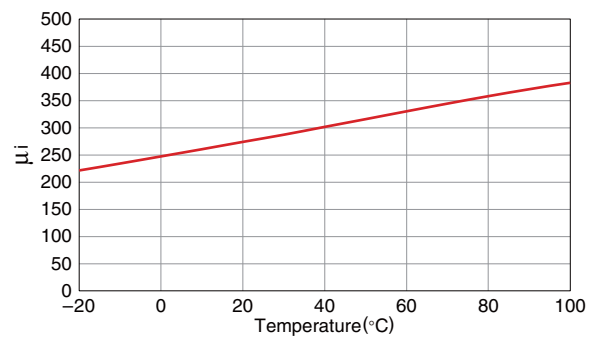

B-H temperature characteristics(Typ.)

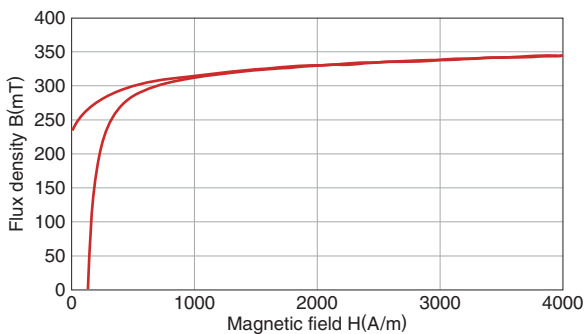

Core Loss(Typ.)

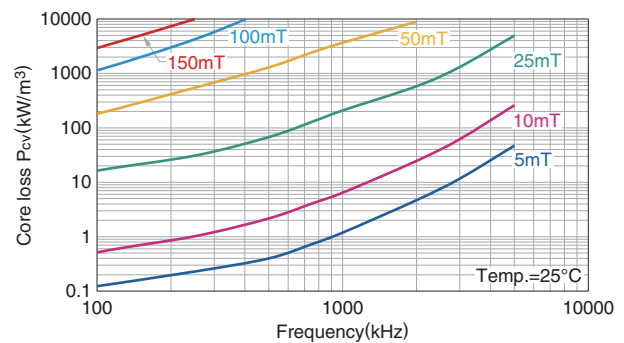

• All specifications are subject to change without notice.

Ni-Zn Ferrite for Coil(Low loss) Material list of SY22

MATERIAL CHARACTERISTICS

| Practical frequency (MHz) | Initial permeability μ_i | Relative loss factor $\tan\delta/\mu_i$ $\times 10^{-6}$ | Temperature factor of initial permeability $\alpha_{\mu i r}$ $\times 10^{-6}/^{\circ}\text{C}$ [20 to 60 $^{\circ}\text{C}$] | Curie temperature T_c ($^{\circ}\text{C}$) | Saturation magnetic flux density B_s (mT) | Remanent flux density B_r (mT) | Coercive force H_c (A/m) | Electrical resistivity ρ_v ($\Omega \cdot \text{m}$) | Density d_b (kg/m^3) |
|------------------------------|---------------------------------|--|---|--|---|--|----------------------------------|---|--|
| 5 to 15 | 80 | <230[1MHz] <100[10MHz] | 25 to 45 | >250 | 310[2kA/m] 330[4kA/m] | 200 | 370 | >10 ⁵ | 5.2 $\times 10^3$ |

μ_i frequency characteristics(Typ.)

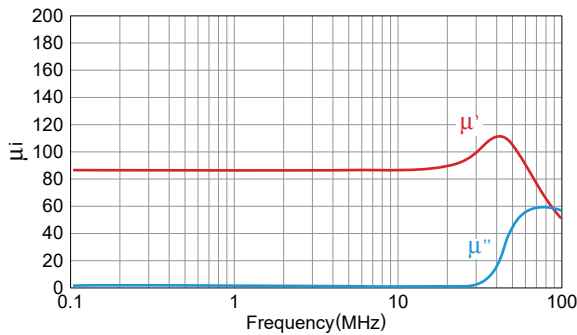

μ_i temperature characteristics(Typ.)

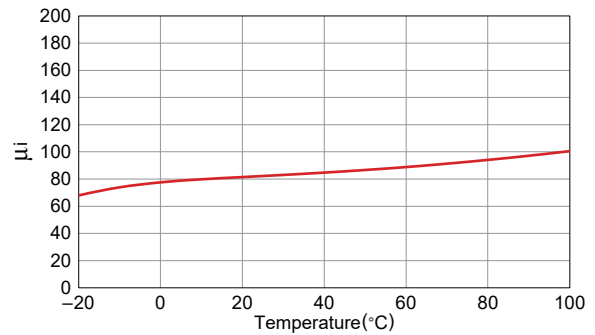

B-H temperature characteristics(Typ.)

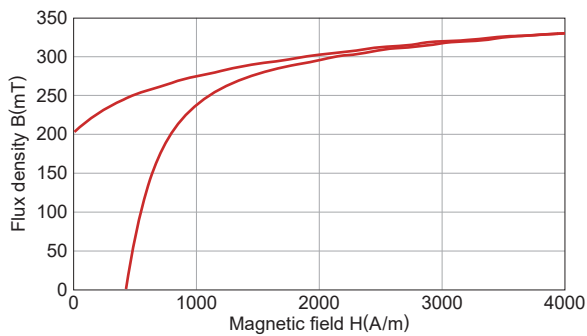

Core Loss(Typ.)

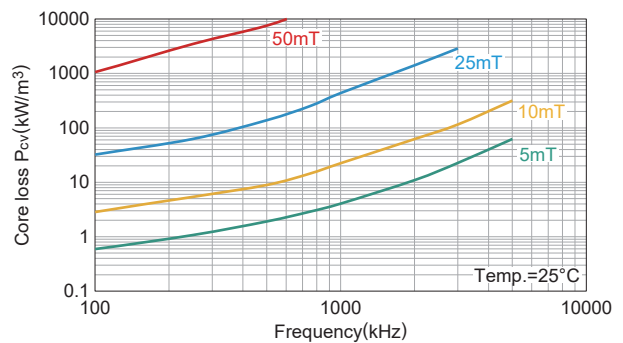

• All specifications are subject to change without notice.

Ni-Zn Ferrite for Coil(High Q) Material list of L5

MATERIAL CHARACTERISTICS

| Practical frequency (MHz) | Initial permeability μ_i | Relative loss factor $\tan\delta/\mu_i$ $\times 10^{-6}$ | Temperature factor of initial permeability $\alpha_{\mu i r}$ $\times 10^{-6}/^{\circ}\text{C}$ [20 to 60 $^{\circ}\text{C}$] | Curie temperature T_c ($^{\circ}\text{C}$) | Saturation magnetic flux density B_s (mT) | Remanent flux density B_r (mT) | Coercive force H_c (A/m) | Electrical resistivity ρ_v ($\Omega \cdot \text{m}$) | Density d_b (kg/m^3) |
|------------------------------|---------------------------------|--|---|--|---|--|----------------------------------|---|--|
| 0.1 to 1.5 | 750 \pm 25% | <15[0.1MHz] <280[1.5MHz] | 1 to 3 | >120 | 310[1.6kA/m] 345[4kA/m] | 105 | 40 | 10 ⁵ | 5 \times 10 ³ |

μ_i frequency characteristics(Typ.)

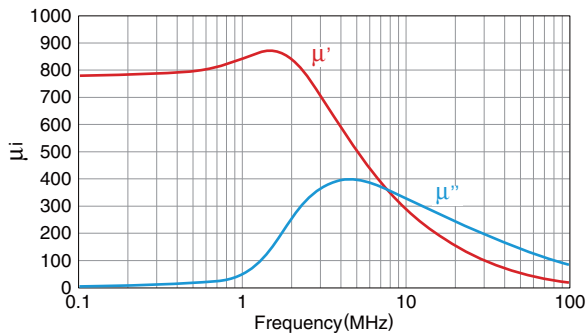

μ_i temperature characteristics(Typ.)

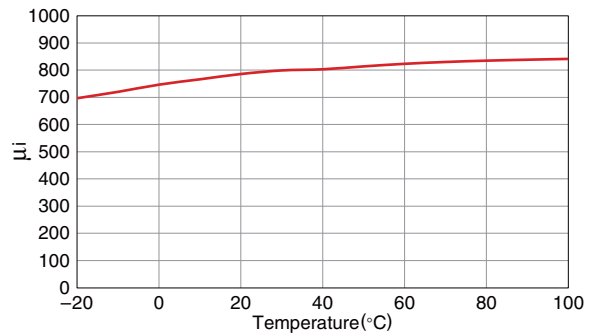

B-H temperature characteristics(Typ.)

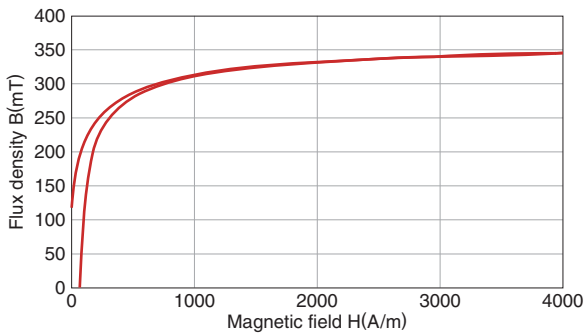

• All specifications are subject to change without notice.

Ni-Zn Ferrite for Coil(High Q) Material list of GT5

MATERIAL CHARACTERISTICS

| Practical frequency (MHz) | Initial permeability μ_i | Relative loss factor $\tan\delta/\mu_i$ $\times 10^{-6}$ | Temperature factor of initial permeability $\alpha_{\mu i r}$ $\times 10^{-6}/^{\circ}\text{C}$ [20 to 60 $^{\circ}\text{C}$] | Curie temperature T_c ($^{\circ}\text{C}$) | Saturation magnetic flux density B_s (mT) | Remanent flux density B_r (mT) | Coercive force H_c (A/m) | Electrical resistivity ρ_v ($\Omega\text{-m}$) | Density d_b (kg/m^3) |
|------------------------------|---------------------------------|--|---|--|---|--|----------------------------------|---|---|
| 3 to 80 | 25 \pm 25% | <470[80MHz] | 30 to 70 | >300 | 300[4kA/m] | 220 | 1100 | 10 ⁵ | 5.1 \times 10 ³ |

μ_i frequency characteristics(Typ.)

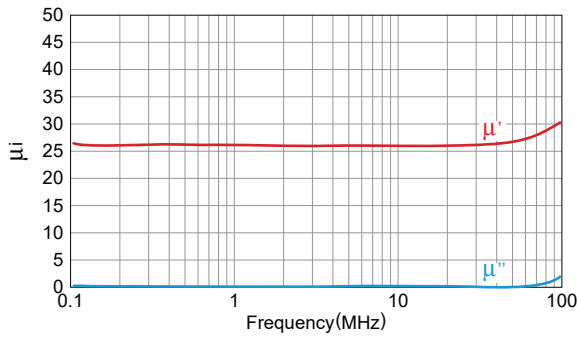

μ_i temperature characteristics(Typ.)

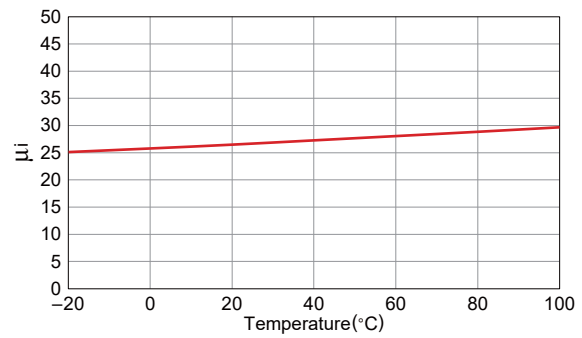

B-H temperature characteristics(Typ.)

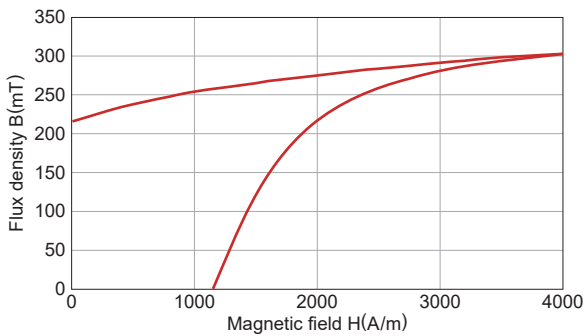

• All specifications are subject to change without notice.

Ni-Zn Ferrite for Coil(High Q) Material list of GT7

MATERIAL CHARACTERISTICS

| Practical frequency (MHz) | Initial permeability μ_i | Relative loss factor $\tan\delta/\mu_i$ $\times 10^{-6}$ | Temperature factor of initial permeability $\alpha_{\mu i r}$ $\times 10^{-6}/^{\circ}\text{C}$ [20 to 60 $^{\circ}\text{C}$] | Curie temperature T_c ($^{\circ}\text{C}$) | Saturation magnetic flux density B_s (mT) | Remanent flux density B_r (mT) | Coercive force H_c (A/m) | Electrical resistivity ρ_v ($\Omega\text{-m}$) | Density d_b (kg/m^3) |
|------------------------------|---------------------------------|--|---|--|---|--|----------------------------------|---|--|
| 10 to 250 | 9 \pm 25% | <1500[250MHz] | 100 to 140 | >300 | 180[16kA/m] | 110 | 2900 | 10 ⁵ | 5.1 \times 10 ³ |

μ_i frequency characteristics(Typ.)

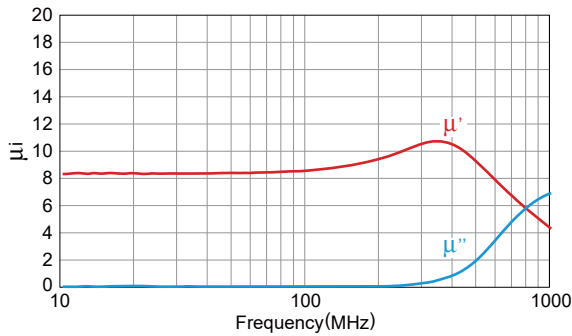

μ_i temperature characteristics(Typ.)

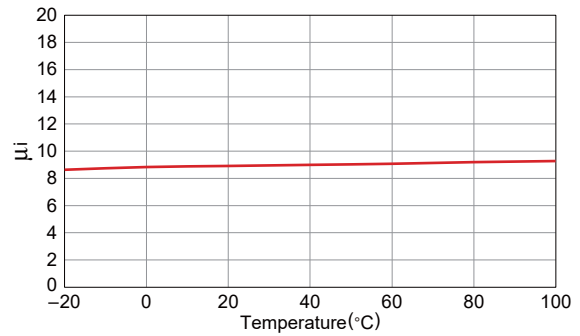

B-H temperature characteristics(Typ.)

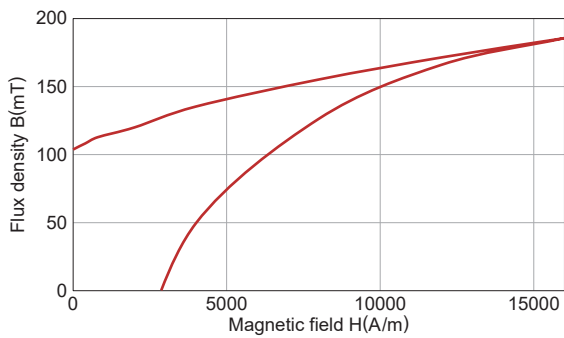

• All specifications are subject to change without notice.

Mn-Zn

Ferrite Core for Switching Power Supplies

E series

EI
EE, EF
EER
ETD

**REMINDERS FOR USING THESE PRODUCTS**

Please be sure to read this manual thoroughly before using the products.

The products listed on this catalog are intended for use in general electronic equipment (AV equipment, telecommunications equipment, home appliances, amusement equipment, computer equipment, personal equipment, office equipment, measurement equipment, industrial robots) under a normal operation and use condition.

The products are not designed or warranted to meet the requirements of the applications listed below, whose performance and/or quality require a more stringent level of safety or reliability, or whose failure, malfunction or trouble could cause serious damage to society, person or property.

When using the products for specific purposes, please first make confirmations in areas such as safety, reliability, and quality.

Please understand that we are not in a position to be held responsible for any damage or the like caused by any use exceeding the range or conditions of this specification sheet or by any use in the specific applications.

- | | |
|---|--|
| (1) Aerospace/Aviation equipment | (8) Public information-processing equipment |
| (2) Transportation equipment (electric trains, ships, etc.) | (9) Military equipment |
| (3) Medical equipment | (10) Electric heating apparatus, burning equipment |
| (4) Power-generation control equipment | (11) Disaster prevention/crime prevention equipment |
| (5) Atomic energy-related equipment | (12) Safety equipment |
| (6) Seabed equipment | (13) Other applications that are not considered general-purpose applications |
| (7) Transportation control equipment | |

When using this product in general-purpose standard applications, you are kindly requested to take into consideration securing protection circuit/equipment or providing backup circuits, etc to ensure higher safety.

Ferrite Cores for Switching Power Supplies

Product compatible with RoHS directive
Halogen-free

Overview of the E Series

FEATURES

- Standard form for use in most commonly used transformers.
- Shape conforms to JIS and IEC standards.
- EF, ETD cores have shapes that are commonly used in Europe.
- A wide range of sizes is available from 8mm to 60mm.

APPLICATION

Switched-mode power supply (SMPS), electronics, power adapters, transformers and coils for chargers

PART NUMBER CONSTRUCTION

| | | | | | | | | | | | | |
|-----------------|-----------------------|-----------|---------|--|----------|------------|------------|---------|-----------|------------|--|--|
| PC47 | EI12.5 | - | Z | | | | | | | | | |
| Material | Size of E core | | | AL-value (Z: without air gap) | | | | | | | | |
| PC47 PC95 | | | | | | | | | | | | |
| | | | | EI core | | | | | | | | |
| | | EI12.5 | EI16 | EI19 | EI22 | EI22/19/6 | EI25 | EI28 | EI30 | EI33/29/13 | | |
| | | EI35 | EI40 | EI50 | EI60 | | | | | | | |
| | | | | EE, EF core | | | | | | | | |
| | | EE8 | EE10/11 | EF12.6 | EE13 | EE16 | SEE16 | EF16 | EE19 | EE19/16 | | |
| | | EE20/20/5 | EF20 | EE22 | EE25/19 | EF25 | EE25.4 | EE30 | EE30/30/7 | EF32 | | |
| | | EE35/28B | EE35 | EE40 | EE41/33C | EE42/42/15 | EE42/42/20 | EE47/39 | EE50 | EE55/55/21 | | |
| | | EE57/47 | EE60 | | | | | | | | | |
| | | | | EER core | | | | | | | | |
| | | EER25.5 | EER25.5 | EER28 | EER28 | EER28L | EER28L | EER35 | EER35 | EER40 | | |
| | | EER40 | EER42 | EER42/42/20 | EER49 | | | | | | | |
| | | | | ETD core | | | | | | | | |
| | | ETD19 | ETD24 | ETD29 | ETD34 | ETD39 | ETD44 | ETD49 | | | | |

RANGE OF USE AND STORAGE TEMPERATURE

| Temperature range | |
|-------------------------------|-----------------------------|
| Operating temperature (°C) | Storage temperature (°C) |
| -30 to +105 | -30 to +85 |

- RoHS Directive Compliant Product: See the following for more details related to RoHS Directive compliant products. <http://product.tdk.com/en/environment/rohs/>
- Halogen-free: Indicates that Cl content is less than 900ppm, Br content is less than 900ppm, and that the total Cl and Br content is less than 1500ppm.

Please be sure to request delivery specifications that provide further details on the features and specifications of the products for proper and safe use. Please note that the contents may change without any prior notice due to reasons such as upgrading.

Mn-Zn EI Cores



SHAPES AND DIMENSIONS

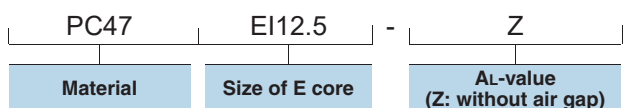
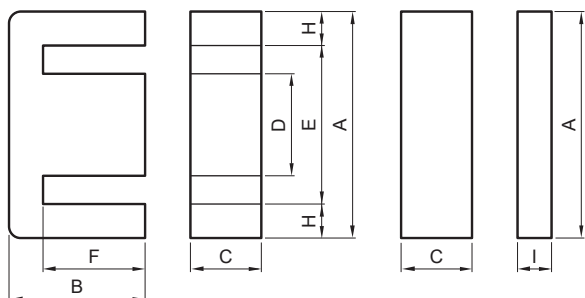

| Part No. | JIS | Dimensions (mm) | | | | | | | |
|-----------------|-----------------|--------------------------------------|------------|--------------------------------------|-----------|--------|------------|------|---------|
| | | A | B | C | D | E min. | F | H | I |
| PC47EI12.5-Z | JIS FEI 12.5 | 12.4±0.3 | 7.4±0.1 | 4.85±0.15 | 2.4±0.1 | 8.8 | 5.1±0.1 | 1.6 | 1.5±0.1 |
| PC47EI16-Z | JIS FEI 16 | 16.0±0.3 | 12.2±0.2 | 4.8±0.2 | 4.0±0.2 | 11.6 | 10.2±0.2 | 2.05 | 2.0±0.2 |
| PC47EI19-Z | | 20.0±0.3 | 13.55±0.25 | 5.0±0.2 | 4.55±0.15 | 14.3 | 11.15±0.15 | 2.75 | 2.3±0.1 |
| PC47EI22-Z | | 22.0±0.3 | 14.55±0.25 | 5.75±0.25 | 5.75±0.25 | 13.0 | 10.55±0.25 | 4.5 | 4.5±0.2 |
| PC47EI22/19/6-Z | JIS FEI 22 | 22.0±0.4 | 14.7±0.2 | 5.75±0.25 | 5.75±0.25 | 15.75 | 10.7±0.2 | 3.0 | 4.0±0.2 |
| PC47EI25-Z | | 25.3±0.5 | 15.55±0.25 | 6.75±0.25 | 6.5±0.3 | 19.0 | 12.35±0.25 | 3.0 | 2.7±0.2 |
| PC47EI28-Z | JIS FEI 28 | 28.0 ^{+0.7} _{-0.5} | 16.75±0.25 | 10.6±0.2(E core) 10.7±0.3(I core) | 7.2±0.3 | 18.4 | 12.25±0.25 | 4.5 | 3.5±0.3 |
| PC47EI30-Z | JIS FEI 30 | 30.0 ^{+0.7} _{-0.4} | 21.25±0.25 | 10.7±0.3 | 10.7±0.3 | 19.7 | 16.25±0.25 | 5.0 | 5.5±0.2 |

| Part No. | Effective parameter | | | | | Electrical characteristics | | |
|-----------------|---|---|---|--|---------------|--|-------------------|---|
| | Core factor C ₁ (mm ⁻¹) | Effective cross-sectional area A _e (mm ²) | Effective magnetic path length ℓ _e (mm) | Effective core volume V _e (mm ³) | Weight (g) | AL-value (nH/N ²) 1kHz 0.5mA 100Ts Without air gap With air gap | | Core loss (W) max. 100kHz 200mT 100°C |
| PC47EI12.5-Z | 1.48 | 14.4 | 21.3 | 308 | 1.9 | 1200±25% | 63±7% 100±10% | 0.1 |
| PC47EI16-Z | 1.75 | 19.8 | 34.6 | 685 | 3.3 | 1100±25% | 80±7% 160±10% | 0.3 |
| PC47EI19-Z | 1.65 | 24.0 | 39.6 | 950 | 5.1 | 1400±25% | 80±7% 160±10% | 0.4 |
| PC47EI22-Z | 0.936 | 42.0 | 39.3 | 1650 | 9.8 | 2400±25% | 125±7% 250±10% | 0.6 |
| PC47EI22/19/6-Z | 1.13 | 37.0 | 41.8 | 1550 | 8.5 | 2000±25% | 125±7% 250±10% | 0.6 |
| PC47EI25-Z | 1.15 | 41.0 | 47.0 | 1930 | 9.8 | 2140±25% | 125±7% 250±10% | 0.8 |
| PC47EI28-Z | 0.56 | 86.0 | 48.2 | 4150 | 22 | 4300±25% | 200±5% 400±7% | 1.6 |
| PC47EI30-Z | 0.522 | 111 | 58.0 | 6440 | 34 | 4690±25% | 200±5% 400±7% | 2.2 |

⚠ Please be sure to request delivery specifications that provide further details on the features and specifications of the products for proper and safe use. Please note that the contents may change without any prior notice due to reasons such as upgrading.

Mn-Zn EI Cores



SHAPES AND DIMENSIONS

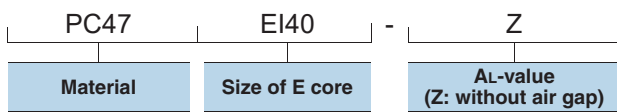
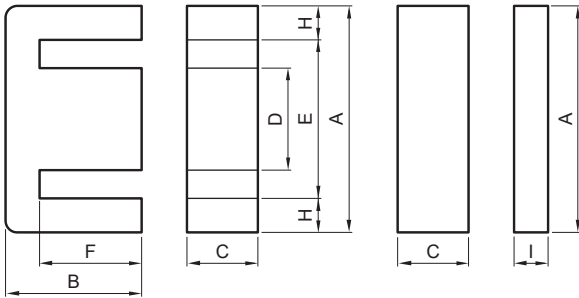

| Part No. | JIS | Dimensions (mm) | | | | | | | |
|------------------|---------------|--------------------------------------|------------|------------|------------|--------|------------|------|---------|
| | | A | B | C | D | E min. | F | H | I |
| PC47EI33/29/13-Z | | 33.0 ^{+0.8} _{-0.5} | 23.75±0.25 | 12.7±0.3 | 9.7±0.3 | 23.4 | 19.25±0.25 | 4.45 | 5.0±0.3 |
| PC47EI35-Z | JIS FEI 35 | 35.0±0.5 | 24.35±0.15 | 10.0±0.3 | 10.0±0.3 | 24.5 | 18.25±0.15 | 5.0 | 4.6±0.3 |
| PC47EI40-Z | JIS FEI 40 | 40.0±0.5 | 27.25±0.25 | 11.65±0.35 | 11.65±0.35 | 27.2 | 20.25±0.25 | 6.2 | 7.5±0.3 |
| PC47EI50-Z | JIS FEI 50 | 50.0 ^{+1.2} _{-0.7} | 33.35±0.35 | 14.6±0.4 | 14.6±0.4 | 33.5 | 24.75±0.25 | 7.7 | 9.0±0.3 |
| PC47EI60-Z | JIS FEI 60 | 60.0 ^{+1.4} _{-0.8} | 35.85±0.35 | 15.6±0.4 | 15.6±0.4 | 43.6 | 27.85±0.35 | 7.7 | 8.5±0.3 |

| Part No. | Effective parameter | | | | | Electrical characteristics | | |
|------------------|---|---|---|--|---------------|--|------------------|---|
| | Core factor C ₁ (mm ⁻¹) | Effective cross-sectional area A _e (mm ²) | Effective magnetic path length ℓ _e (mm) | Effective core volume V _e (mm ³) | Weight (g) | AL-value (nH/N ²) 1kHz 0.5mA 100Ts Without air gap With air gap | | Core loss (W) max. 100kHz 200mT 100°C |
| PC47EI33/29/13-Z | 0.567 | 119 | 67.5 | 8030 | 41 | 4400±25% | 200±5% 400±7% | 2.7 |
| PC47EI35-Z | 0.664 | 101 | 67.1 | 6780 | 36 | 3800±25% | 200±5% 400±7% | 2.3 |
| PC47EI40-Z | 0.520 | 148 | 77.0 | 11400 | 60 | 4860±25% | 200±5% 400±7% | 3.7 |
| PC47EI50-Z | 0.409 | 230 | 94.0 | 21620 | 115 | 6110±25% | 250±5% 500±7% | 8.6 |
| PC47EI60-Z | 0.441 | 247 | 109 | 26900 | 139 | 5670±25% | 250±5% 500±7% | 9.2 |

⚠ Please be sure to request delivery specifications that provide further details on the features and specifications of the products for proper and safe use. Please note that the contents may change without any prior notice due to reasons such as upgrading.

Mn-Zn E series Part No.: PC47EI12.5-Z

SHAPES AND DIMENSIONS

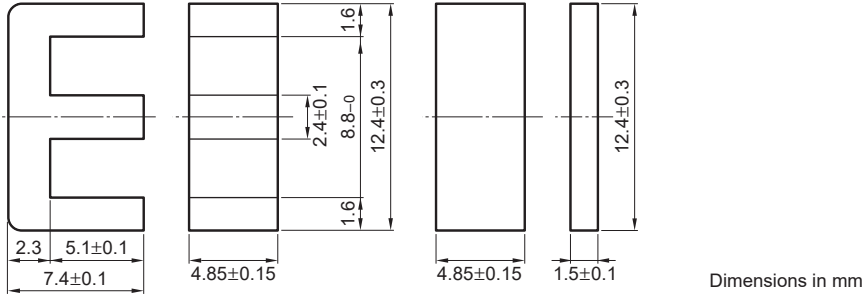

Based on JIS FEI 12.5.

| Effective parameter | | | | | | | | Electrical characteristics | | |
|------------------------|---|---|--|--|---|--|----------------|----------------------------|-----------------|--------------------------|
| Core factor | Effective magnetic path length l_e (mm) | Effective cross-sectional area A_e (mm ²) | Effective core volume V_e (mm ³) | Cross-sectional center pole area A_{cp} (mm ²) | Minimum cross-sectional center pole area $A_{cp \text{ min.}}$ (mm ²) | Cross-sectional winding area of core A_{cw} (mm ²) | Weight (g/set) | AL-value * | | Core loss |
| C1 (mm ⁻¹) | | | | | | | | (nH/N ²) | | (W)max. |
| 1.48 | 21.3 | 14.4 | 308 | 11.6 | 10.8 | 17.3 | 1.9 | 1kHz 0.5mA | 100kHz 200mT | 100kHz 200mT 100°C |
| | | | | | | | | 1200±25% | 2120 min. | 0.10 |

* Coil : ø0.2 2UEW 100Ts

○ Calculated output power (forward converter mode): 11.5W (100kHz)

NI limit vs. AL-value (Typ.)

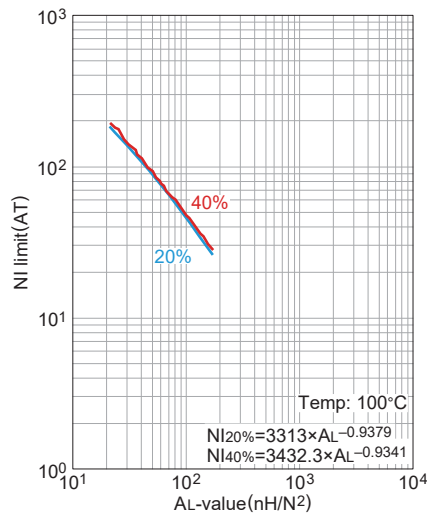

The 20% and 40% graph shows when a 20% and 40% drop from the initial AL-value has been made due to the DC superimposition.

AL-value vs. Air gap length (Typ.)

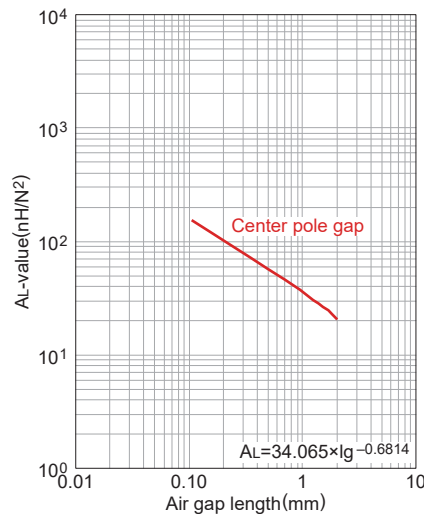

Measuring conditions
 • Coil : ø0.2 2UEW 100Ts
 • Frequency : 1kHz
 • Current level : 0.5mA
 • Ambient temperature : 25°C

Temperature rise vs. Total loss (Typ.)

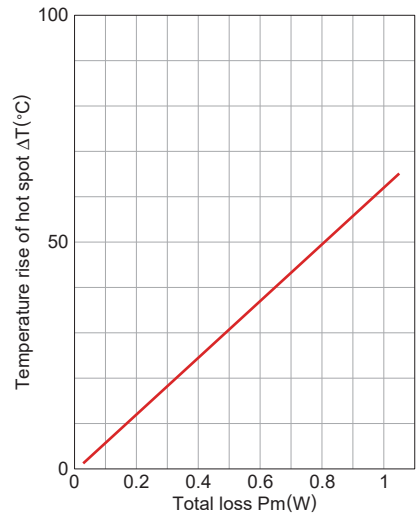

Measuring conditions
 • Room space: approx. 400x300x 300cm
 • Ambient temperature : 25°C
 • Humidity: 45%(%)RH.

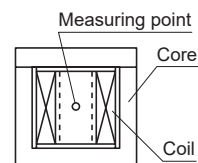

⚠ Please be sure to request delivery specifications that provide further details on the features and specifications of the products for proper and safe use. Please note that the contents may change without any prior notice due to reasons such as upgrading.

Mn-Zn E series Part No.: PC47EI16-Z

SHAPES AND DIMENSIONS

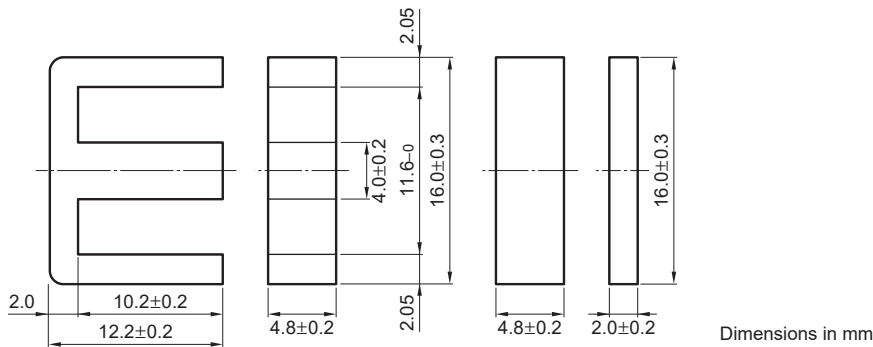

Based on JIS FEI 16.

| Effective parameter | | | | | | | | Electrical characteristics | | |
|------------------------------------|--|---|--|--|---|--|----------------|---------------------------------------|-----------------|-------------------------------------|
| Core factor | Effective magnetic path length ℓ_e (mm) | Effective cross-sectional area A_e (mm ²) | Effective core volume V_e (mm ³) | Cross-sectional center pole area A_{cp} (mm ²) | Minimum cross-sectional center pole area $A_{cp \text{ min.}}$ (mm ²) | Cross-sectional winding area of core A_{cw} (mm ²) | Weight (g/set) | AL-value * | | Core loss |
| C ₁ (mm ⁻¹) | | | | | | | | (nH/N ²) 1kHz 0.5mA | 100kHz 200mT | (W)max. 100kHz 200mT 100°C |
| 1.75 | 34.6 | 19.8 | 685 | 19.2 | 17.5 | 40.3 | 3.3 | 1100±25% | 1750 min. | 0.29 |

* Coil : ϕ 0.23 2UEW 100Ts

○ Calculated output power (forward converter mode): 33W (100kHz)

NI limit vs. AL-value (Typ.)

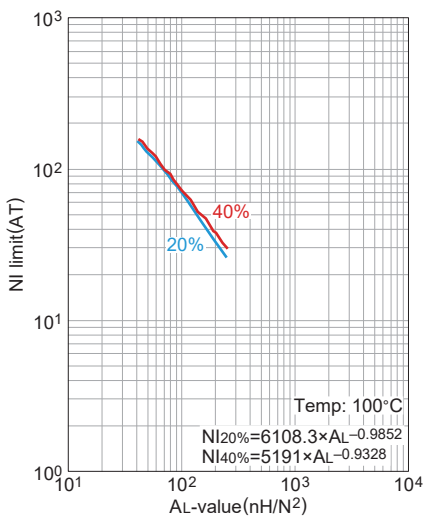

The 20% and 40% graph shows when a 20% and 40% drop from the initial AL-value has been made due to the DC superimposition.

AL-value vs. Air gap length (Typ.)

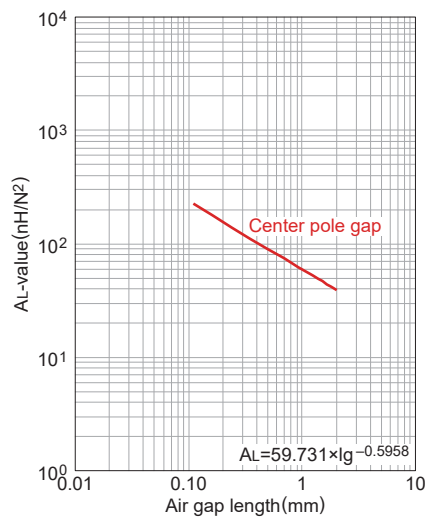

Measuring conditions

- Coil : ϕ 0.23 2UEW 100Ts
- Frequency : 1kHz
- Current level : 0.5mA
- Ambient temperature : 25°C

Temperature rise vs. Total loss (Typ.)

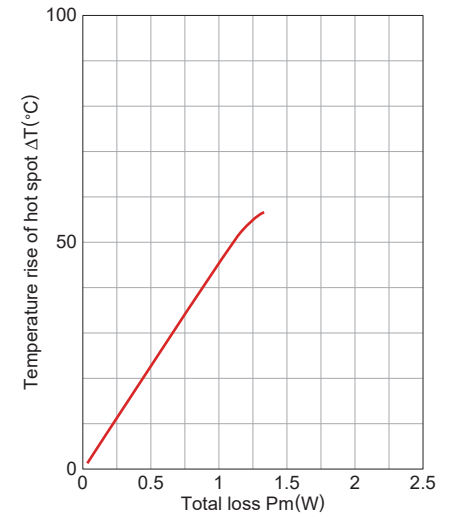

Measuring conditions

- Room space: approx. 400x300x 300cm
- Ambient temperature : 25°C
- Humidity: 45%(%)RH.

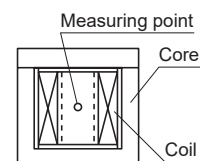

⚠ Please be sure to request delivery specifications that provide further details on the features and specifications of the products for proper and safe use. Please note that the contents may change without any prior notice due to reasons such as upgrading.

Mn-Zn E series Part No.: PC47EI19-Z

SHAPES AND DIMENSIONS

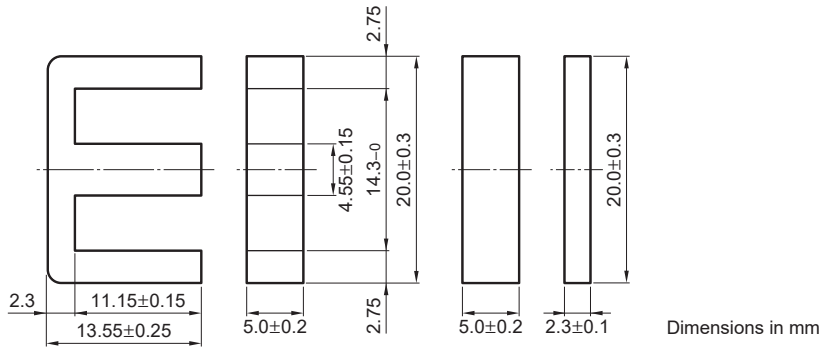

Based on JIS FEI 12.5.

| Effective parameter | | | | | | | | Electrical characteristics | | |
|------------------------|--|---|--|--|---|--|----------------|----------------------------|-----------------|--------------------------|
| Core factor | Effective magnetic path length ℓ_e (mm) | Effective cross-sectional area A_e (mm ²) | Effective core volume V_e (mm ³) | Cross-sectional center pole area A_{cp} (mm ²) | Minimum cross-sectional center pole area $A_{cp \text{ min.}}$ (mm ²) | Cross-sectional winding area of core A_{cw} (mm ²) | Weight (g/set) | AL-value * | | Core loss |
| C1 (mm ⁻¹) | | | | | | | | (nH/N ²) | | (W)max. |
| 1.65 | 39.6 | 24.0 | 950 | 22.8 | 21.1 | 55.5 | 5.1 | 1kHz 0.5mA | 100kHz 200mT | 100kHz 200mT 100°C |
| | | | | | | | | 1400±25% | 1830 min. | 0.39 |

* Coil : ø0.23 2UEW 100Ts

○ Calculated output power (forward converter mode): 45W (100kHz)

NI limit vs. AL-value (Typ.)

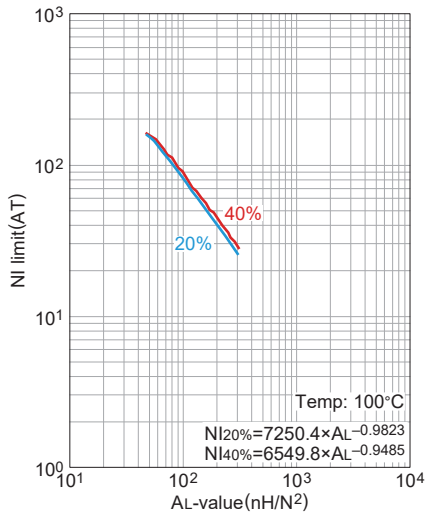

The 20% and 40% graph shows when a 20% and 40% drop from the initial AL-value has been made due to the DC superimposition.

AL-value vs. Air gap length (Typ.)

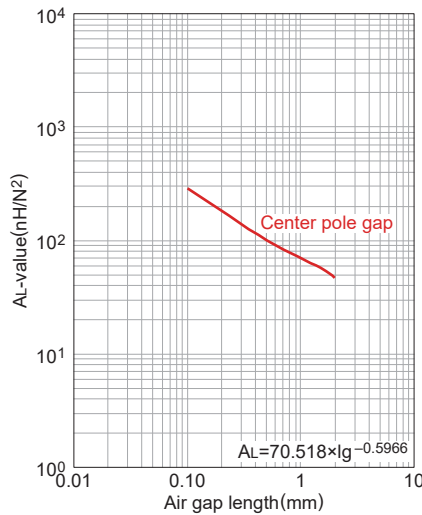

Measuring conditions

- Coil : ø0.23 2UEW 100Ts
- Frequency : 1kHz
- Current level : 0.5mA
- Ambient temperature : 25°C

Temperature rise vs. Total loss (Typ.)

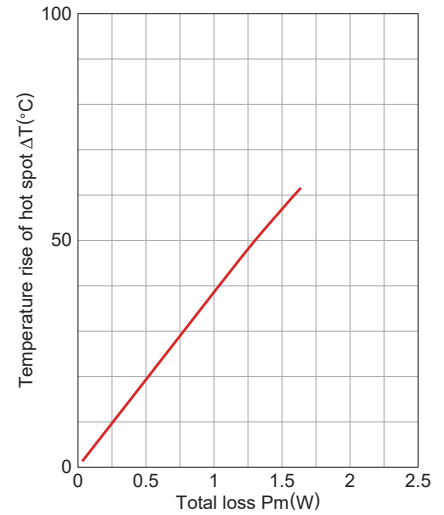

Measuring conditions

- Room space: approx. 400x300x 300cm
- Ambient temperature : 25°C
- Humidity: 45%(%)RH.

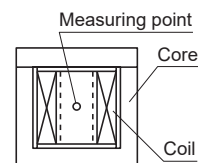

⚠ Please be sure to request delivery specifications that provide further details on the features and specifications of the products for proper and safe use. Please note that the contents may change without any prior notice due to reasons such as upgrading.

Mn-Zn E series Part No.: PC47EI22-Z

SHAPES AND DIMENSIONS

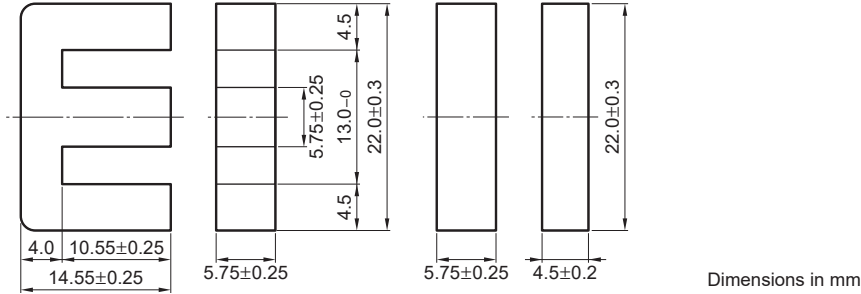

Based on JIS FEI 12.5.

| Effective parameter | | | | | | | | Electrical characteristics | | |
|------------------------|--|---|--|--|---|--|----------------|----------------------------|-----------------|--------------------------|
| Core factor | Effective magnetic path length ℓ_e (mm) | Effective cross-sectional area A_e (mm ²) | Effective core volume V_e (mm ³) | Cross-sectional center pole area A_{cp} (mm ²) | Minimum cross-sectional center pole area $A_{cp \text{ min.}}$ (mm ²) | Cross-sectional winding area of core A_{cw} (mm ²) | Weight (g/set) | AL-value * | | Core loss |
| C1 (mm ⁻¹) | | | | | | | | (nH/N ²) | | (W)max. |
| 0.936 | 39.3 | 42.0 | 1650 | 33.1 | 30.3 | 38.2 | 9.8 | 1kHz 0.5mA | 100kHz 200mT | 100kHz 200mT 100°C |
| | | | | | | | | 2400±25% | 3360 min. | 0.56 |

* Coil : ø0.23 2UEW 100Ts

○ Calculated output power (forward converter mode): 49W (100kHz)

NI limit vs. AL-value (Typ.)

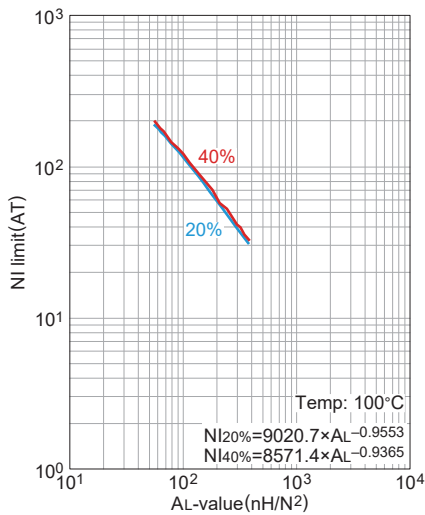

The 20% and 40% graph shows when a 20% and 40% drop from the initial AL-value has been made due to the DC superimposition.

AL-value vs. Air gap length (Typ.)

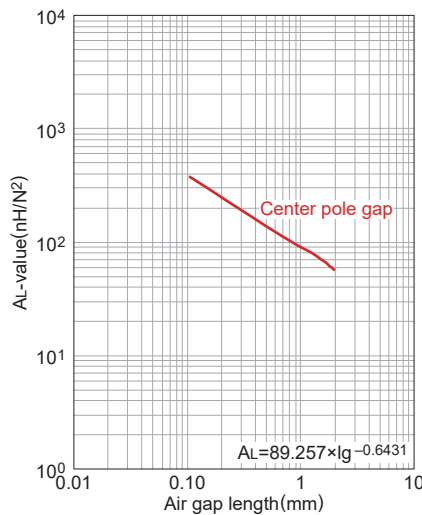

Measuring conditions

- Coil : ø0.23 2UEW 100Ts
- Frequency : 1kHz
- Current level : 0.5mA
- Ambient temperature : 25°C

Temperature rise vs. Total loss (Typ.)

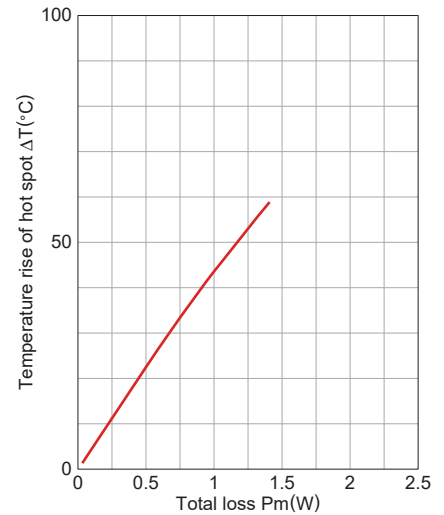

Measuring conditions

- Room space: approx. 400x300x 300cm
- Ambient temperature : 25°C
- Humidity: 45%(%)RH.

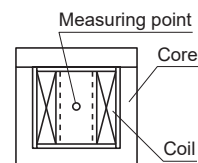

⚠ Please be sure to request delivery specifications that provide further details on the features and specifications of the products for proper and safe use. Please note that the contents may change without any prior notice due to reasons such as upgrading.

Mn-Zn E series Part No.: PC47EI22/19/6-Z

SHAPES AND DIMENSIONS

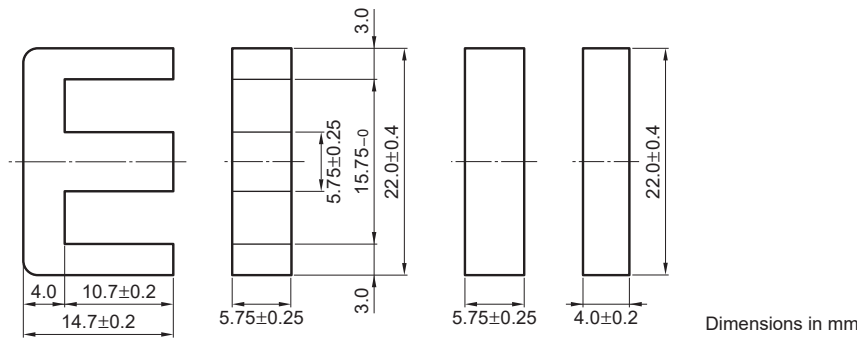

Based on JIS FEI 22.

| Effective parameter | | | | | | | | Electrical characteristics | | |
|------------------------|--|---|--|--|---|--|----------------|----------------------------|-----------------|--------------------------|
| Core factor | Effective magnetic path length ℓ_e (mm) | Effective cross-sectional area A_e (mm ²) | Effective core volume V_e (mm ³) | Cross-sectional center pole area A_{cp} (mm ²) | Minimum cross-sectional center pole area $A_{cp \text{ min.}}$ (mm ²) | Cross-sectional winding area of core A_{cw} (mm ²) | Weight (g/set) | AL-value * | | Core loss |
| C1 (mm ⁻¹) | | | | | | | | (nH/N ²) | | (W)max. |
| 1.13 | 41.8 | 37.0 | 1550 | 33.1 | 30.3 | 54.8 | 8.5 | 1kHz 0.5mA | 100kHz 200mT | 100kHz 200mT 100°C |
| | | | | | | | | 2000±25% | 2780 min. | 0.59 |

* Coil : ø0.23 2UEW 100Ts

○ Calculated output power (forward converter mode): 59W (100kHz)

NI limit vs. AL-value (Typ.)

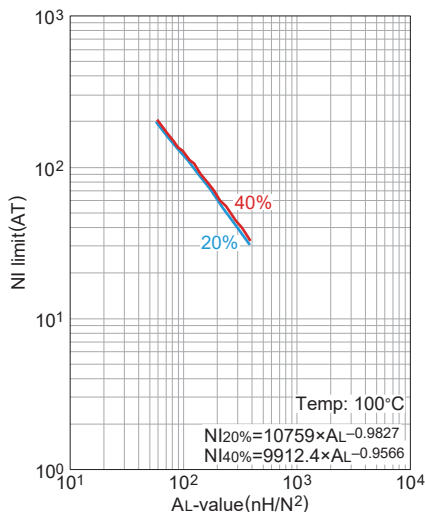

The 20% and 40% graph shows when a 20% and 40% drop from the initial AL-value has been made due to the DC superimposition.

AL-value vs. Air gap length (Typ.)

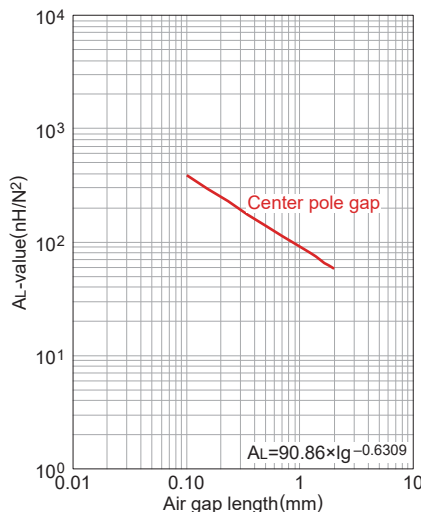

Measuring conditions
 • Coil : ø0.23 2UEW 100Ts
 • Frequency : 1kHz
 • Current level : 0.5mA
 • Ambient temperature : 25°C

Temperature rise vs. Total loss (Typ.)

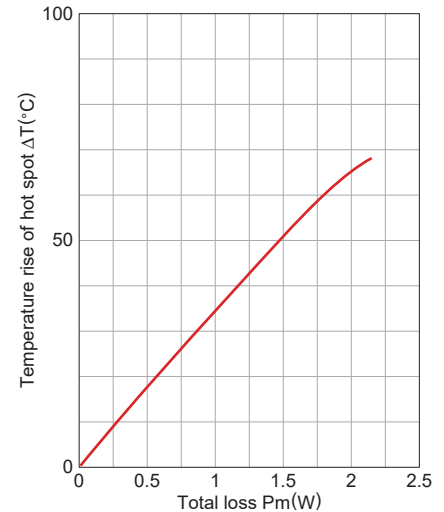

Measuring conditions
 • Room space: approx. 400x300x 300cm
 • Ambient temperature : 25°C
 • Humidity : 45%(%)RH.

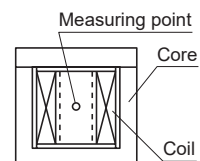

⚠ Please be sure to request delivery specifications that provide further details on the features and specifications of the products for proper and safe use. Please note that the contents may change without any prior notice due to reasons such as upgrading.

Mn-Zn E series Part No.: PC47EI25-Z

SHAPES AND DIMENSIONS

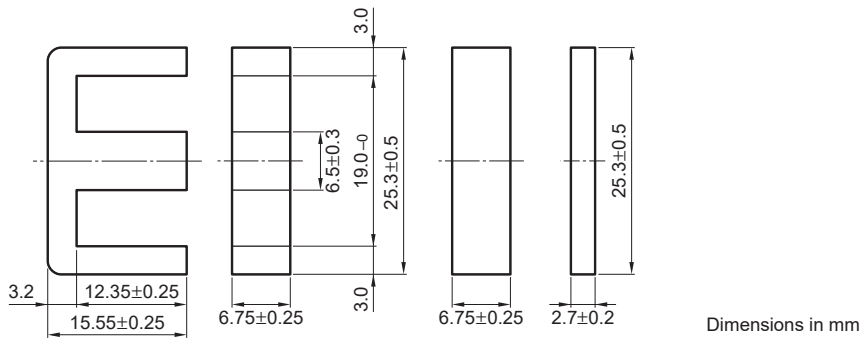

Based on JIS FEI 12.5.

| Effective parameter | | | | | | | | Electrical characteristics | | |
|------------------------|--|---|--|--|---|--|----------------|----------------------------|-----------------|--------------------------|
| Core factor | Effective magnetic path length ℓ_e (mm) | Effective cross-sectional area A_e (mm ²) | Effective core volume V_e (mm ³) | Cross-sectional center pole area A_{cp} (mm ²) | Minimum cross-sectional center pole area $A_{cp \text{ min.}}$ (mm ²) | Cross-sectional winding area of core A_{cw} (mm ²) | Weight (g/set) | AL-value * | | Core loss |
| C1 (mm ⁻¹) | | | | | | | | (nH/N ²) | | (W)max. |
| 1.15 | 47.0 | 41.0 | 1930 | 43.9 | 40.3 | 77.2 | 9.8 | 1kHz 0.5mA | 100kHz 200mT | 100kHz 200mT 100°C |
| | | | | | | | | 2140±25% | 2950 min. | 0.82 |

* Coil : $\phi 0.35$ 2UEW 100Ts

○ Calculated output power (forward converter mode): 82W (100kHz)

NI limit vs. AL-value (Typ.)

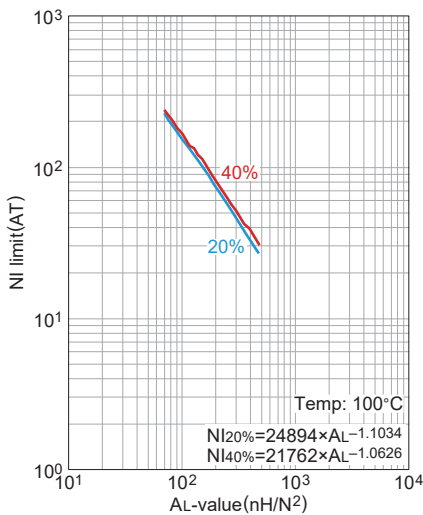

The 20% and 40% graph shows when a 20% and 40% drop from the initial AL-value has been made due to the DC superimposition.

AL-value vs. Air gap length (Typ.)

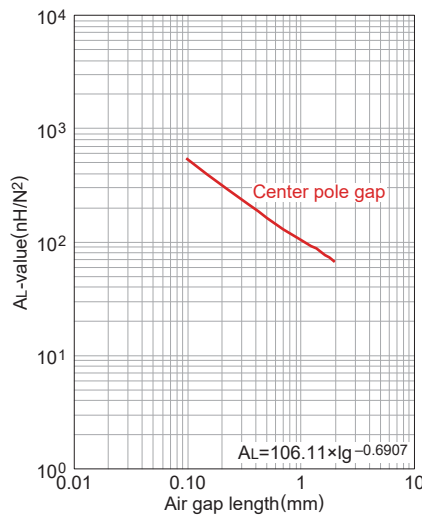

Measuring conditions
 • Coil : $\phi 0.35$ 2UEW 100Ts
 • Frequency : 1kHz
 • Current level : 0.5mA
 • Ambient temperature : 25°C

Temperature rise vs. Total loss (Typ.)

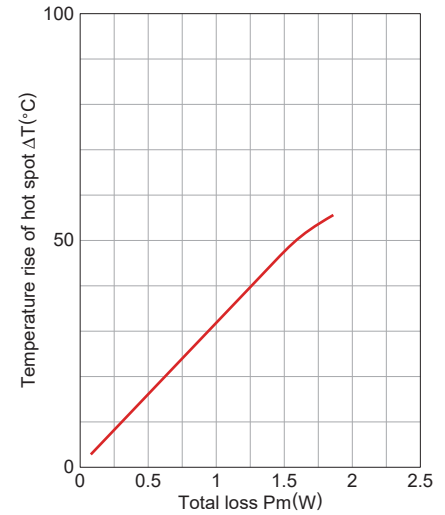

Measuring conditions
 • Room space: approx. 400x300x 300cm
 • Ambient temperature : 25°C
 • Humidity: 45(%RH).

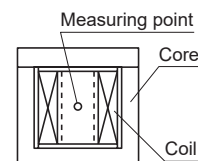

⚠ Please be sure to request delivery specifications that provide further details on the features and specifications of the products for proper and safe use. Please note that the contents may change without any prior notice due to reasons such as upgrading.

Mn-Zn E series Part No.: PC47EI28-Z

SHAPES AND DIMENSIONS

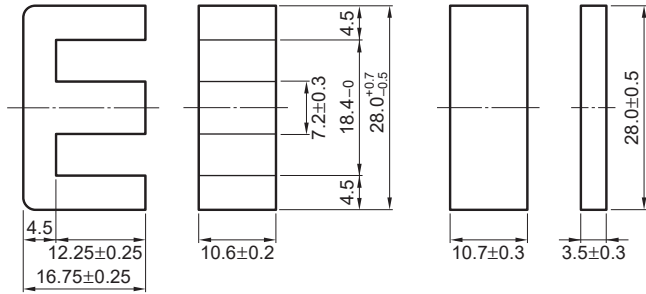

Dimensions in mm

Based on JIS FEI 28.

| Effective parameter | | | | | | | | Electrical characteristics | | |
|------------------------|--|---|--|--|---|--|----------------|----------------------------|-----------------|--------------------------|
| Core factor | Effective magnetic path length ℓ_e (mm) | Effective cross-sectional area A_e (mm ²) | Effective core volume V_e (mm ³) | Cross-sectional center pole area A_{cp} (mm ²) | Minimum cross-sectional center pole area $A_{cp \text{ min.}}$ (mm ²) | Cross-sectional winding area of core A_{cw} (mm ²) | Weight (g/set) | AL-value * | | Core loss |
| C1 (mm ⁻¹) | | | | | | | | (nH/N ²) | | (W)max. |
| 0.560 | 48.2 | 86.0 | 4150 | 76.3 | 71.8 | 69.8 | 22 | 1kHz 0.5mA | 100kHz 200mT | 100kHz 200mT 100°C |
| | | | | | | | | 4300±25% | 6060 min. | 1.58 |

* Coil : ø0.35 2UEW 100Ts

○ Calculated output power (forward converter mode): 145W (100kHz)

NI limit vs. AL-value (Typ.)

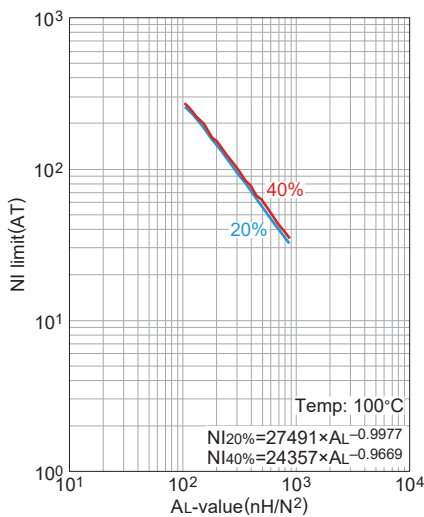

The 20% and 40% graph shows when a 20% and 40% drop from the initial AL-value has been made due to the DC superimposition.

AL-value vs. Air gap length (Typ.)

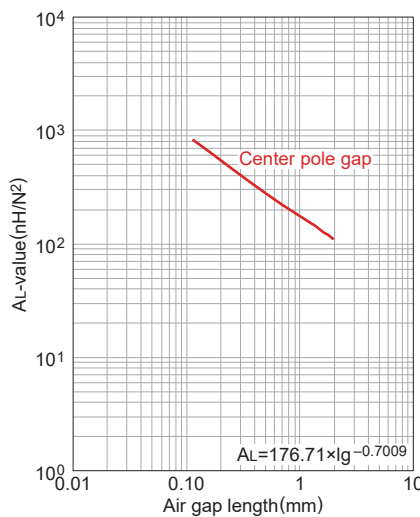

Measuring conditions
 • Coil : ø0.35 2UEW 100Ts
 • Frequency : 1kHz
 • Current level : 0.5mA
 • Ambient temperature : 25°C

Temperature rise vs. Total loss (Typ.)

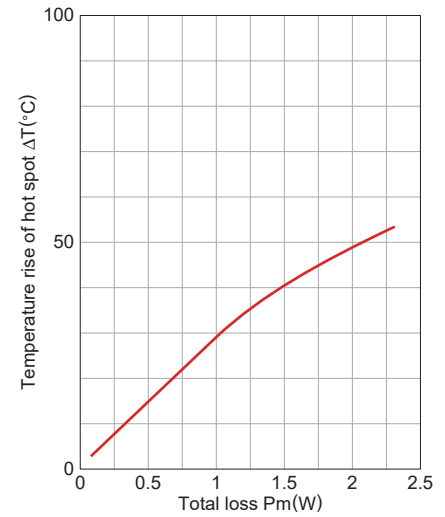

Measuring conditions
 • Room space: approx. 400x300x 300cm
 • Ambient temperature : 25°C
 • Humidity: 45%(%)RH.

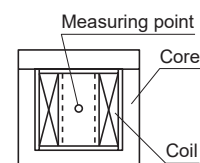

⚠ Please be sure to request delivery specifications that provide further details on the features and specifications of the products for proper and safe use. Please note that the contents may change without any prior notice due to reasons such as upgrading.

Mn-Zn E series Part No.: PC47EI30-Z

SHAPES AND DIMENSIONS

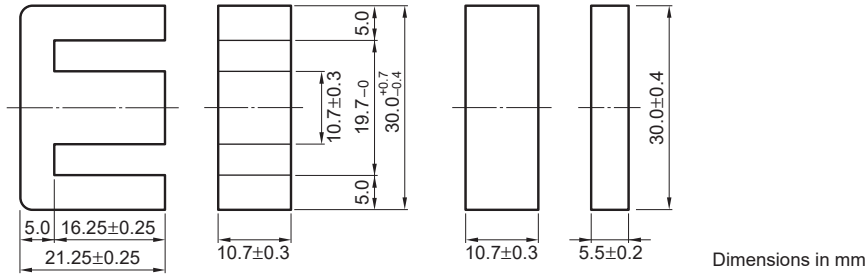

Based on JIS FEI 30.

| Effective parameter | | | | | | | | Electrical characteristics | | |
|------------------------|---|---|--|--|---|--|----------------|----------------------------|-----------------|--------------------------|
| Core factor | Effective magnetic path length l_e (mm) | Effective cross-sectional area A_e (mm ²) | Effective core volume V_e (mm ³) | Cross-sectional center pole area A_{cp} (mm ²) | Minimum cross-sectional center pole area $A_{cp \text{ min.}}$ (mm ²) | Cross-sectional winding area of core A_{cw} (mm ²) | Weight (g/set) | AL-value * | | Core loss |
| C1 (mm ⁻¹) | | | | | | | | (nH/N ²) | | (W)max. |
| 0.523 | 58.0 | 111 | 6440 | 114 | 108 | 75.6 | 34 | 1kHz 0.5mA | 100kHz 200mT | 100kHz 200mT 100°C |
| | | | | | | | | 4690±25% | 6490 min. | 2.17 |

*Coil : ø0.35 2UEW 100Ts

○ Calculated output power (forward converter mode): 214W (100kHz)

NI limit vs. AL-value (Typ.)

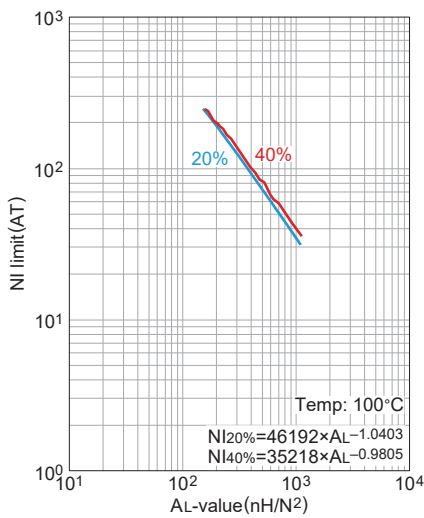

The 20% and 40% graph shows when a 20% and 40% drop from the initial AL-value has been made due to the DC superimposition.

AL-value vs. Air gap length (Typ.)

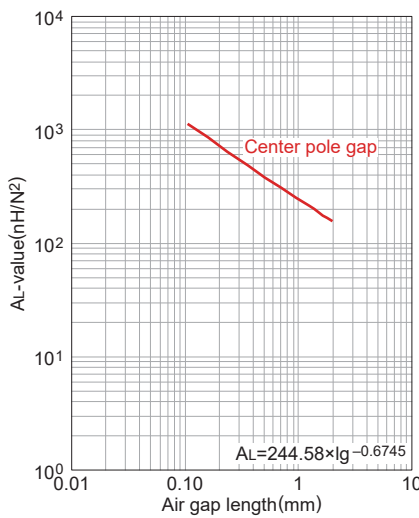

Measuring conditions

- Coil : ø0.35 2UEW 100Ts
- Frequency : 1kHz
- Current level : 0.5mA
- Ambient temperature : 25°C

Temperature rise vs. Total loss (Typ.)

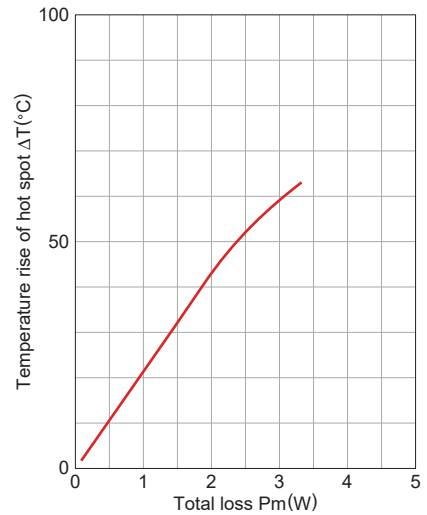

Measuring conditions

- Room space: approx. 400x300x 300cm
- Ambient temperature : 25°C
- Humidity : 45(%RH).

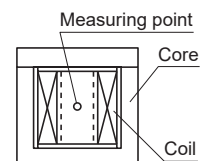

⚠ Please be sure to request delivery specifications that provide further details on the features and specifications of the products for proper and safe use. Please note that the contents may change without any prior notice due to reasons such as upgrading.

Mn-Zn E series Part No.: PC47EI33/29/13-Z

SHAPES AND DIMENSIONS

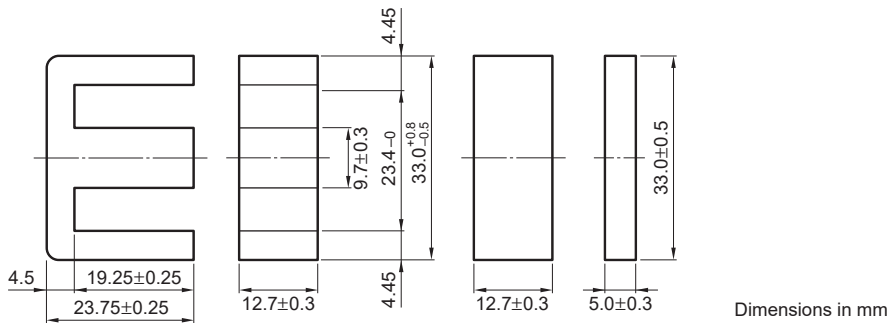

| Effective parameter | | | | | | | | Electrical characteristics | | |
|------------------------|--|---|--|--|---|--|----------------|----------------------------|-----------------|--------------------------|
| Core factor | Effective magnetic path length ℓ_e (mm) | Effective cross-sectional area A_e (mm ²) | Effective core volume V_e (mm ³) | Cross-sectional center pole area A_{cp} (mm ²) | Minimum cross-sectional center pole area $A_{cp \text{ min.}}$ (mm ²) | Cross-sectional winding area of core A_{cw} (mm ²) | Weight (g/set) | AL-value * | | Core loss |
| C1 (mm ⁻¹) | | | | | | | | (nH/N ²) | | (W)max. |
| 0.567 | 67.5 | 119 | 8030 | 123 | 117 | 138.6 | 41 | 1kHz 0.5mA | 100kHz 200mT | 100kHz 200mT 100°C |
| | | | | | | | | 4400±25% | 5980 min. | 2.67 |

* Coil : ø0.35 2UEW 100Ts

○ Calculated output power (forward converter mode): 288W (100kHz)

NI limit vs. AL-value (Typ.)

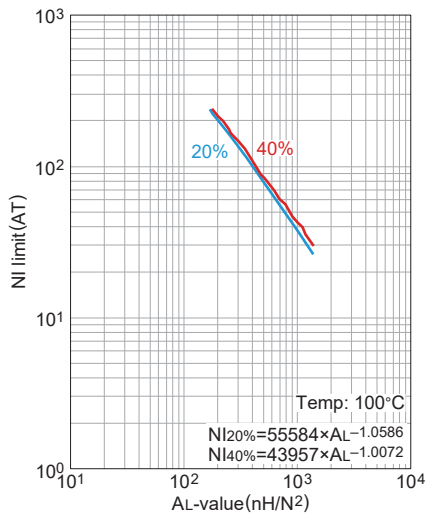

The 20% and 40% graph shows when a 20% and 40% drop from the initial AL-value has been made due to the DC superimposition.

AL-value vs. Air gap length (Typ.)

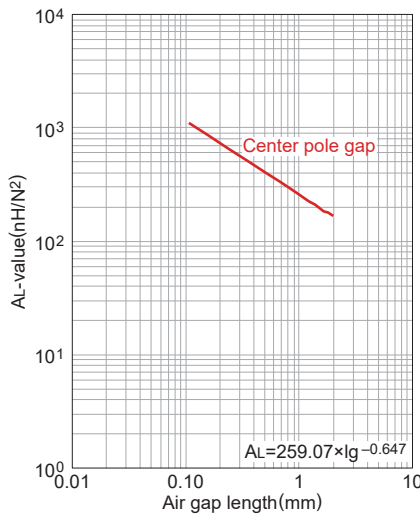

Measuring conditions

- Coil : ø0.35 2UEW 100Ts
- Frequency : 1kHz
- Current level : 0.5mA
- Ambient temperature : 25°C

Temperature rise vs. Total loss (Typ.)

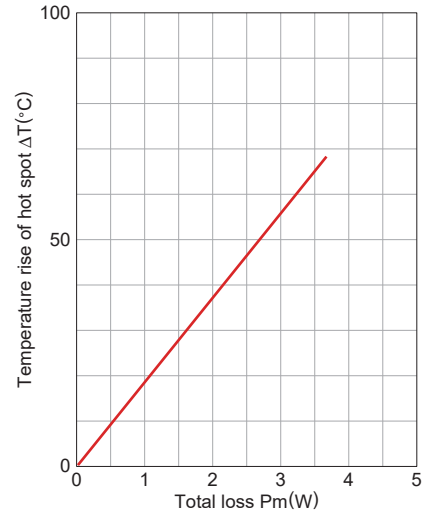

Measuring conditions

- Room space: approx. 400x300x 300cm
- Ambient temperature : 25°C
- Humidity: 45(%)RH.

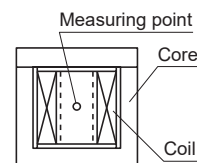

⚠ Please be sure to request delivery specifications that provide further details on the features and specifications of the products for proper and safe use. Please note that the contents may change without any prior notice due to reasons such as upgrading.

Mn-Zn E series Part No.: PC47EI35-Z

SHAPES AND DIMENSIONS

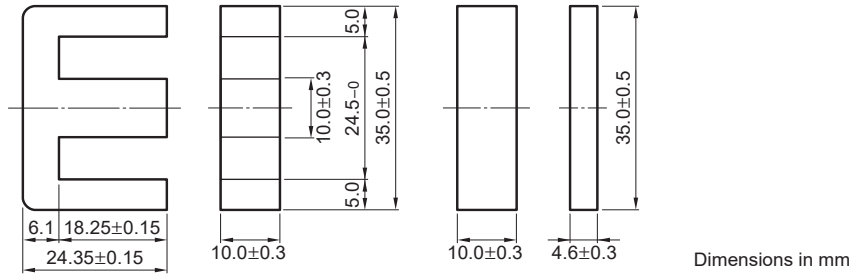

Based on JIS FEI 35.

| Effective parameter | | | | | | | | Electrical characteristics | | |
|------------------------|---|---|--|--|---|--|----------------|----------------------------|-----------------|--------------------------|
| Core factor | Effective magnetic path length l_e (mm) | Effective cross-sectional area A_e (mm ²) | Effective core volume V_e (mm ³) | Cross-sectional center pole area A_{cp} (mm ²) | Minimum cross-sectional center pole area $A_{cp \text{ min.}}$ (mm ²) | Cross-sectional winding area of core A_{cw} (mm ²) | Weight (g/set) | AL-value * | | Core loss |
| C1 (mm ⁻¹) | | | | | | | | (nH/N ²) | | (W)max. |
| 0.664 | 67.1 | 101 | 6780 | 100 | 94.1 | 131.6 | 36 | 1kHz 0.5mA | 100kHz 200mT | 100kHz 200mT 100°C |
| | | | | | | | | 3800±25% | 5110 min. | 2.35 |

* Coil : $\phi 0.35$ 2UEW 100Ts

○ Calculated output power (forward converter mode): 266W (100kHz)

NI limit vs. AL-value (Typ.)

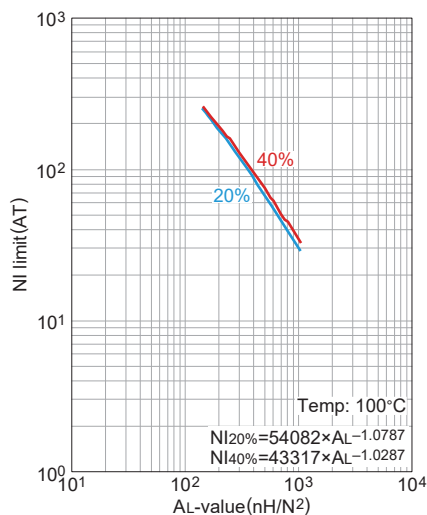

The 20% and 40% graph shows when a 20% and 40% drop from the initial AL-value has been made due to the DC superimposition.

AL-value vs. Air gap length (Typ.)

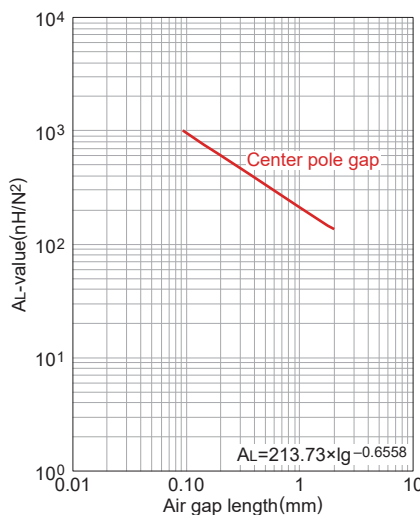

Measuring conditions
 • Coil : $\phi 0.35$ 2UEW 100Ts
 • Frequency : 1kHz
 • Current level : 0.5mA
 • Ambient temperature : 25°C

Temperature rise vs. Total loss (Typ.)

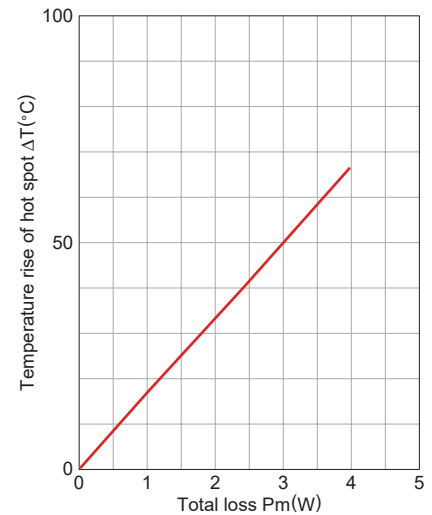

Measuring conditions
 • Room space: approx. 400x300x 300cm
 • Ambient temperature : 25°C
 • Humidity : 45(%)RH.

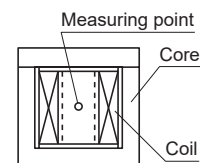

⚠ Please be sure to request delivery specifications that provide further details on the features and specifications of the products for proper and safe use. Please note that the contents may change without any prior notice due to reasons such as upgrading.

Mn-Zn E series Part No.: PC47EI40-Z

SHAPES AND DIMENSIONS

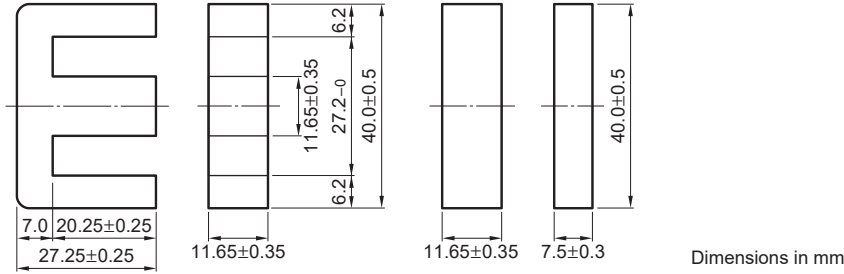

Based on JIS FEI 40.

| Effective parameter | | | | | | | | Electrical characteristics | | |
|------------------------|--|---|--|--|---|--|----------------|----------------------------|-----------------|--------------------------|
| Core factor | Effective magnetic path length ℓ_e (mm) | Effective cross-sectional area A_e (mm ²) | Effective core volume V_e (mm ³) | Cross-sectional center pole area A_{cp} (mm ²) | Minimum cross-sectional center pole area $A_{cp \text{ min.}}$ (mm ²) | Cross-sectional winding area of core A_{cw} (mm ²) | Weight (g/set) | AL-value * | | Core loss |
| C1 (mm ⁻¹) | | | | | | | | (nH/N ²) | | (W)max. |
| 0.520 | 77.0 | 148 | 11400 | 136 | 128 | 160.5 | 60 | 1kHz 0.5mA | 100kHz 200mT | 100kHz 200mT 100°C |
| | | | | | | | | 4860±25% | 6520 min. | 3.66 |

* Coil : $\phi 0.35$ 2UEW 100Ts

○ Calculated output power (forward converter mode): 361W (100kHz)

NI limit vs. AL-value (Typ.)

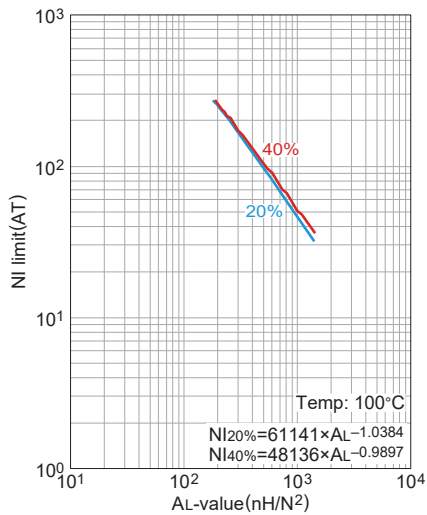

The 20% and 40% graph shows when a 20% and 40% drop from the initial AL-value has been made due to the DC superimposition.

AL-value vs. Air gap length (Typ.)

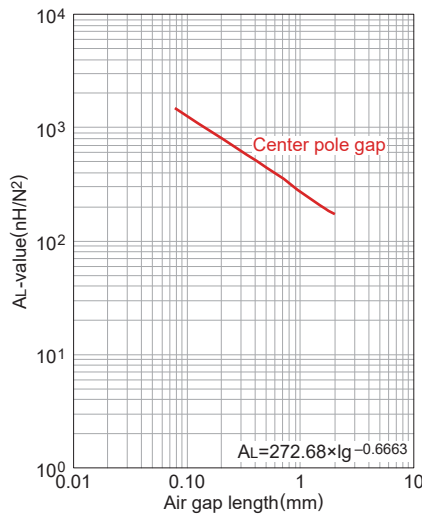

Measuring conditions

- Coil : $\phi 0.35$ 2UEW 100Ts
- Frequency : 1kHz
- Current level : 0.5mA
- Ambient temperature : 25°C

Temperature rise vs. Total loss (Typ.)

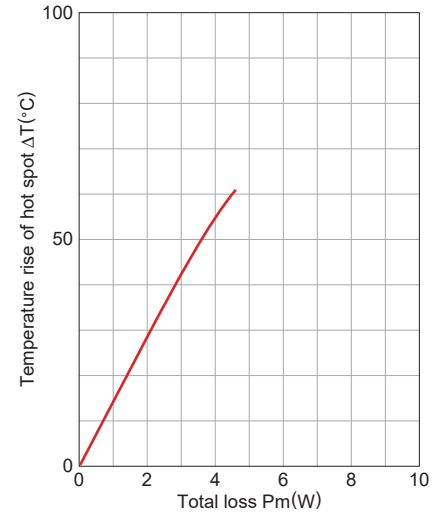

Measuring conditions

- Room space: approx. 400x300x 300cm
- Ambient temperature : 25°C
- Humidity : 45(%RH).

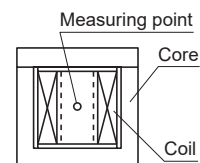

⚠ Please be sure to request delivery specifications that provide further details on the features and specifications of the products for proper and safe use. Please note that the contents may change without any prior notice due to reasons such as upgrading.

Mn-Zn E series Part No.: PC47EI50-Z

SHAPES AND DIMENSIONS

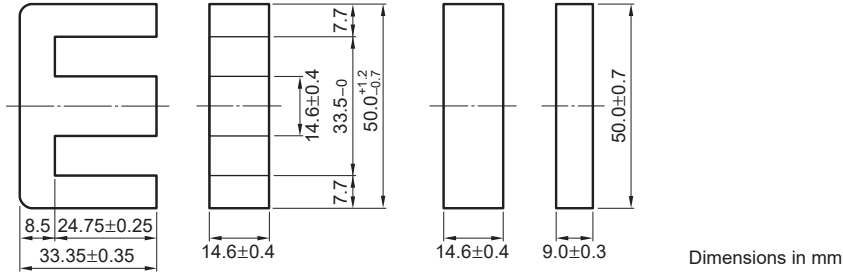

Based on JIS FEI 50.

| Effective parameter | | | | | | | | Electrical characteristics | | |
|------------------------|--|---|--|--|---|--|----------------|----------------------------|-----------------|--------------------------|
| Core factor | Effective magnetic path length ℓ_e (mm) | Effective cross-sectional area A_e (mm ²) | Effective core volume V_e (mm ³) | Cross-sectional center pole area A_{cp} (mm ²) | Minimum cross-sectional center pole area $A_{cp \text{ min.}}$ (mm ²) | Cross-sectional winding area of core A_{cw} (mm ²) | Weight (g/set) | AL-value * | | Core loss |
| C1 (mm ⁻¹) | | | | | | | | (nH/N ²) | | (W)max. |
| 0.409 | 94.0 | 230 | 21620 | 213 | 202 | 246.3 | 115 | 1kHz 0.5mA | 100kHz 200mT | 100kHz 200mT 100°C |
| | | | | | | | | 6110±25% | 8300 min. | 8.62 |

* Coil : ø0.35 2UEW 100Ts

○ Calculated output power (forward converter mode): 554W (100kHz)

NI limit vs. AL-value (Typ.)

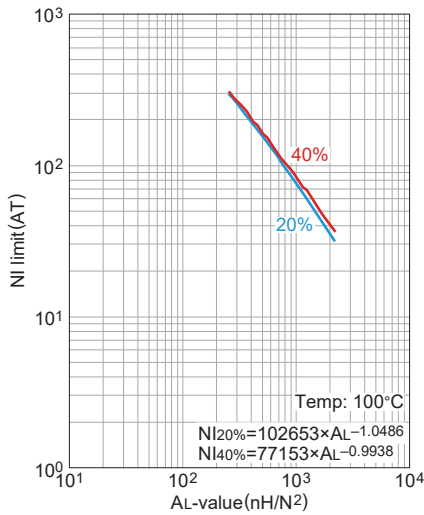

The 20% and 40% graph shows when a 20% and 40% drop from the initial AL-value has been made due to the DC superimposition.

AL-value vs. Air gap length (Typ.)

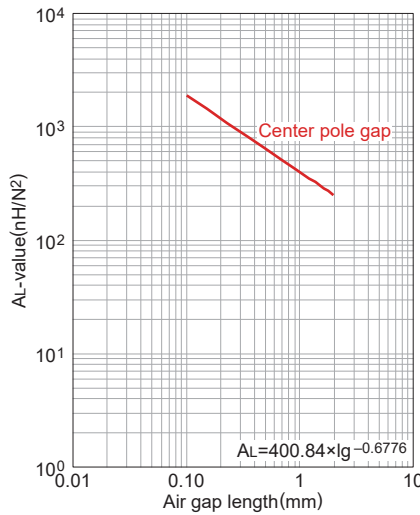

Measuring conditions
 • Coil : ø0.35 2UEW 100Ts
 • Frequency : 1kHz
 • Current level : 0.5mA
 • Ambient temperature : 25°C

Temperature rise vs. Total loss (Typ.)

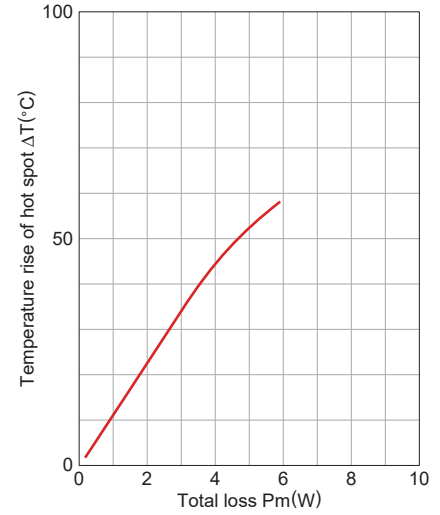

Measuring conditions
 • Room space: approx. 400x300x 300cm
 • Ambient temperature : 25°C
 • Humidity : 45(%RH).

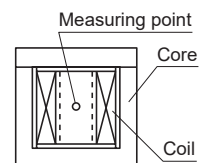

⚠ Please be sure to request delivery specifications that provide further details on the features and specifications of the products for proper and safe use. Please note that the contents may change without any prior notice due to reasons such as upgrading.

Mn-Zn E series Part No.: PC47EI60-Z

SHAPES AND DIMENSIONS

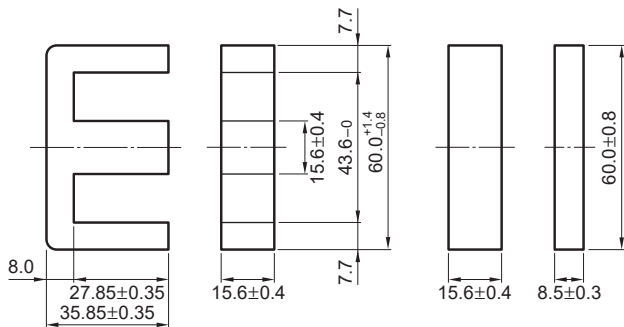

Dimensions in mm

Based on JIS FEI 60.

| Effective parameter | | | | | | | | Electrical characteristics | | |
|------------------------|--|---|--|--|---|--|----------------|----------------------------|-----------------|--------------------------|
| Core factor | Effective magnetic path length ℓ_e (mm) | Effective cross-sectional area A_e (mm ²) | Effective core volume V_e (mm ³) | Cross-sectional center pole area A_{cp} (mm ²) | Minimum cross-sectional center pole area $A_{cp \text{ min.}}$ (mm ²) | Cross-sectional winding area of core A_{cw} (mm ²) | Weight (g/set) | AL-value * | | Core loss |
| C1 (mm ⁻¹) | | | | | | | | (nH/N ²) | | (W)max. |
| 0.441 | 109 | 247 | 26900 | 243 | 231 | 402.4 | 139 | 1kHz 0.5mA | 100kHz 200mT | 100kHz 200mT 100°C |
| | | | | | | | | 5670±25% | 7690 min. | 9.16 |

* Coil : $\phi 0.35$ 2UEW 100Ts

○ Calculated output power (forward converter mode): 712W (100kHz)

NI limit vs. AL-value (Typ.)

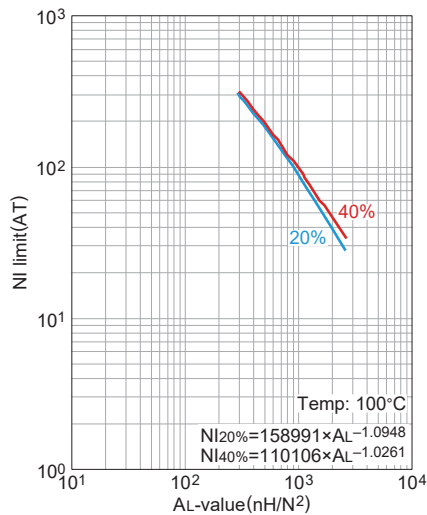

The 20% and 40% graph shows when a 20% and 40% drop from the initial AL-value has been made due to the DC superimposition.

AL-value vs. Air gap length (Typ.)

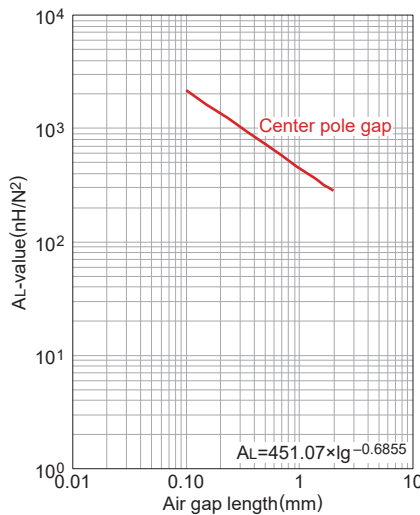

Measuring conditions
 • Coil : $\phi 0.35$ 2UEW 100Ts
 • Frequency : 1kHz
 • Current level : 0.5mA
 • Ambient temperature : 25°C

Temperature rise vs. Total loss (Typ.)

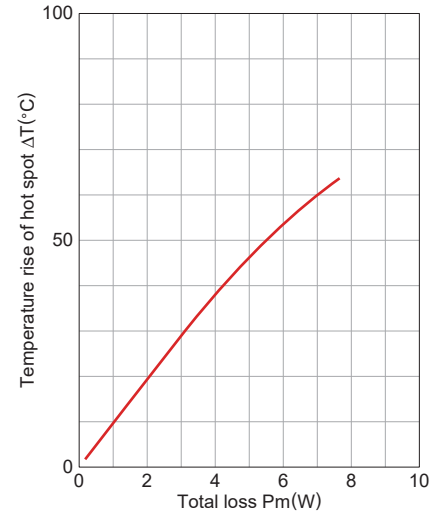

Measuring conditions
 • Room space: approx. 400x300x 300cm
 • Ambient temperature : 25°C
 • Humidity : 45(%)RH.

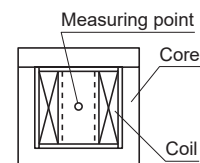

⚠ Please be sure to request delivery specifications that provide further details on the features and specifications of the products for proper and safe use. Please note that the contents may change without any prior notice due to reasons such as upgrading.

Mn-Zn EE, EF Cores

SHAPES AND DIMENSIONS

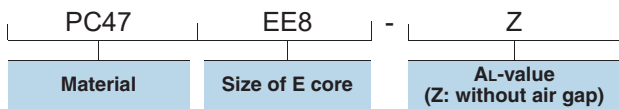
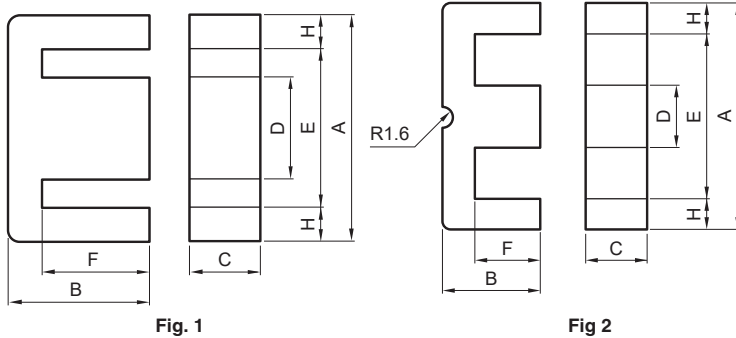

| Part No. | U.S. lam. cores, DIN standard JIS | Core | Dimensions (mm) | | | | | | |
|---------------|-----------------------------------|------|-----------------|-----------|-----------|-----------|--------|-----------|------|
| | | | A | B | C | D | E min. | F | H |
| PC47EE8-Z | JIS FEE 8.3 | 1 | 8.3±0.2 | 4.0±0.1 | 3.6±0.2 | 1.85±0.15 | 6.0 | 3.0±0.1 | 1.0 |
| PC47EE10/11-Z | JIS FEE 10.2 | 1 | 10.2±0.2 | 5.5±0.1 | 4.75±0.15 | 2.45±0.15 | 7.7 | 4.20±0.15 | 1.1 |
| PC47EF12.6-Z | DIN 41985 | 1 | 12.7±0.4 | 6.4±0.1 | 3.6±0.2 | 3.65±0.15 | 8.8 | 4.65±0.15 | 1.83 |
| PC47EE13-Z | | 1 | 13.0±0.2 | 6.00±0.15 | 6.15±0.15 | 2.75±0.15 | 10.0 | 4.6±0.1 | 1.4 |
| PC47EE16-Z | JIS FEE 16A | 1 | 16.0±0.3 | 7.15±0.15 | 4.8±0.2 | 4.0±0.2 | 11.7 | 5.1±0.2 | 2.0 |
| PC47SEE16-Z | | 1 | 16.0±0.3 | 7.15±0.15 | 6.8±0.2 | 3.18±0.18 | 12.5 | 5.5±0.1 | 1.6 |
| PC47EF16-Z | DIN 41985 | 1 | 16.1±0.6 | 8.05±0.15 | 4.5±0.2 | 4.55±0.15 | 11.3 | 5.9±0.2 | 2.2 |
| PC47EE19-Z | JIS FEE 19A | 1 | 19.1±0.3 | 7.95±0.15 | 5.0±0.2 | 4.55±0.15 | 14.2 | 5.6±0.1 | 2.3 |

| Part No. | Effective parameter | | | | | Electrical characteristics | | |
|---------------|---|---|---|--|---------------|--|------------------|---|
| | Core factor C ₁ (mm ⁻¹) | Effective cross-sectional area A _e (mm ²) | Effective magnetic path length ℓ _e (mm) | Effective core volume V _e (mm ³) | Weight (g) | AL-value (nH/N ²) 1kHz 0.5mA 100Ts | | Core loss (W) max. 100kHz 200mT 100°C |
| | | | | | | Without air gap | With air gap | |
| PC47EE8-Z | 2.75 | 7.0 | 19.2 | 134 | 0.7 | 610±25% | 40±7% 63±10% | 0.05 |
| PC47EE10/11-Z | 2.16 | 12.1 | 26.1 | 315 | 1.5 | 850±25% | 40±7% 63±10% | 0.12 |
| PC47EF12.6-Z | 2.28 | 13.0 | 29.6 | 385 | 2.0 | 810±25% | 63±7% 100±10% | 0.16 |
| PC47EE13-Z | 1.77 | 17.1 | 30.2 | 517 | 2.7 | 1130±25% | 63±7% 100±10% | 0.22 |
| PC47EE16-Z | 1.82 | 19.0 | 34.5 | 656 | 3.3 | 1140±25% | 80±7% 160±10% | 0.28 |
| PC47SEE16-Z | 1.69 | 21.7 | 36.6 | 795 | 4.1 | 1240±25% | 80±7% 160±10% | 0.34 |
| PC47EF16-Z | 1.87 | 20.1 | 37.6 | 754 | 3.9 | 1100±25% | 63±7% 100±10% | 0.31 |
| PC47EE19-Z | 1.71 | 23.0 | 39.4 | 906 | 4.8 | 1250±25% | 80±7% 160±10% | 0.39 |

⚠ Please be sure to request delivery specifications that provide further details on the features and specifications of the products for proper and safe use. Please note that the contents may change without any prior notice due to reasons such as upgrading.

Mn-Zn EE, EF Cores

SHAPES AND DIMENSIONS

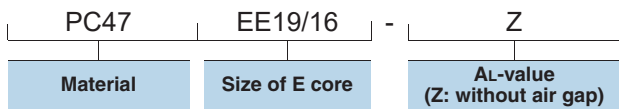
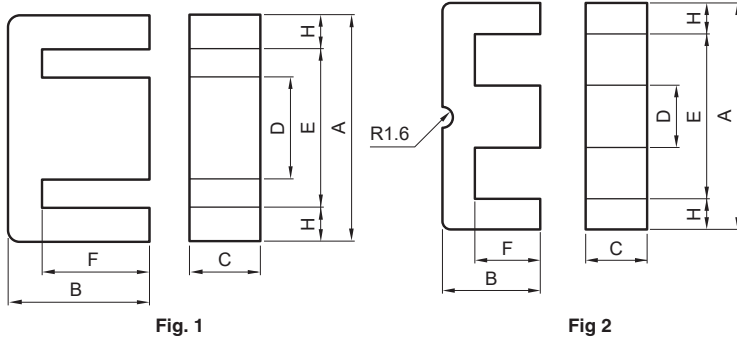

| Part No. | U.S. lam. cores, DIN standard JIS | | Core | Dimensions (mm) | | | | | | |
|-----------------|-----------------------------------|--|------|-----------------|------------|-----------|-----------|--------|-------------|------|
| | | | | A | B | C | D | E min. | F | H |
| PC47EE19/16-Z | U.S. EE-187 | | 1 | 19.29±0.32 | 8.1±0.18 | 4.75±0.13 | 4.75±0.08 | 14.05 | 5.715±0.125 | 2.46 |
| PC47EE20/20/5-Z | DIN 41295 | | 2 | 20.15±0.55 | 10.0±0.2 | 5.1±0.2 | 5.0±0.2 | 12.8 | 6.5±0.2 | 3.53 |
| PC47EF20-Z | DIN 41985 | | 1 | 20.0±0.4 | 9.9±0.2 | 5.65±0.25 | 5.7±0.2 | 14.1 | 7.2±0.2 | 2.8 |
| PC47EE22-Z | | | 1 | 22.0±0.3 | 9.35±0.15 | 5.75±0.25 | 5.75±0.25 | 13.0 | 5.35±0.15 | 4.3 |
| PC47EE25/19-Z | U.S. EE-24/25 | | 1 | 25.4±0.5 | 9.46±0.19 | 6.29±0.19 | 6.35±0.25 | 18.55 | 6.41±0.19 | 3.11 |
| PC47EF25-Z | DIN 41985 | | 1 | 25.05±0.75 | 12.55±0.25 | 7.2±0.3 | 7.25±0.25 | 17.5 | 8.95±0.25 | 3.55 |
| PC47EE25.4-Z | JIS FEE 25.4A | | 1 | 25.4±0.76 | 9.66±0.15 | 6.35±0.25 | 6.35±0.25 | 18.5 | 6.48±0.15 | 3.18 |
| PC47EE30-Z | JIS FEE 30A | | 1 | 30.0±0.5 | 13.15±0.15 | 10.7±0.3 | 10.7±0.3 | 19.7 | 8.15±0.15 | 5.0 |

| Part No. | Effective parameter | | | | | Electrical characteristics | | |
|-----------------|---|---|---|--|--------------|--|-------------------|---|
| | Core factor C ₁ (mm ⁻¹) | Effective cross-sectional area A _e (mm ²) | Effective magnetic path length ℓ _e (mm) | Effective core volume V _e (mm ³) | Weigh (g) | AL-value (nH/N ²) 1kHz 0.5mA 100Ts Without air gap With air gap | | Core loss (W) max. 100kHz 200mT 100°C |
| PC47EE19/16-Z | 1.75 | 22.4 | 39.1 | 876 | 4.8 | 1350±25% | 80±7% 160±10% | 0.38 |
| PC47EE20/20/5-Z | 1.38 | 31.0 | 43.0 | 1340 | 7.5 | 1400±25% | 100±7% 160±10% | 0.47 |
| PC47EF20-Z | 1.34 | 33.5 | 44.9 | 1500 | 7.4 | 1570±25% | 100±7% 160±10% | 0.59 |
| PC47EE22-Z | 0.970 | 41.0 | 39.6 | 1620 | 8.8 | 2180±25% | 125±7% 250±10% | 0.56 |
| PC47EE25/19-Z | 1.22 | 40.0 | 48.7 | 1950 | 9.1 | 2000±25% | 100±7% 200±10% | 0.80 |
| PC47EF25-Z | 1.11 | 51.8 | 57.8 | 2990 | 15 | 2000±25% | 100±7% 160±10% | 1.27 |
| PC47EE25.4-Z | 1.21 | 40.3 | 48.7 | 1963 | 10 | 2000±25% | 125±7% 250±10% | 0.84 |
| PC47EE30-Z | 0.529 | 109.0 | 57.7 | 6290 | 32 | 4690±25% | 200±5% 400±7% | 2.03 |

⚠ Please be sure to request delivery specifications that provide further details on the features and specifications of the products for proper and safe use. Please note that the contents may change without any prior notice due to reasons such as upgrading.

Mn-Zn EE, EF Cores

SHAPES AND DIMENSIONS

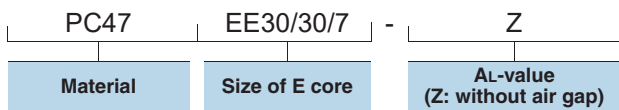
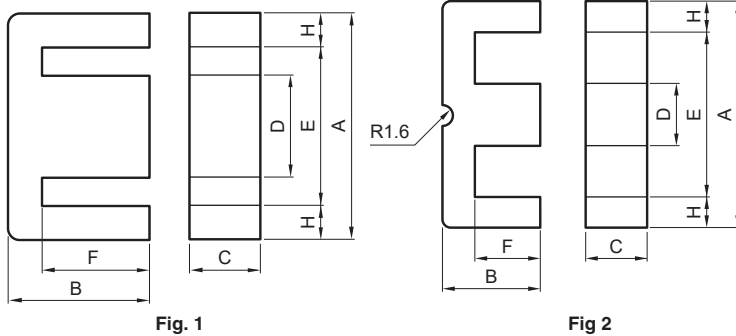

| Part No. | U.S. lam. cores, DIN standard JIS | | Core | Dimensions (mm) | | | | | | |
|------------------|-----------------------------------|------------|------|-----------------|------------|------------|------------|-------|------------|-------|
| | A | B | | C | D | E min. | F | H | | |
| PC47EE30/30/7-Z | DIN 41295 | | 2 | 30.1±0.7 | 15.0±0.2 | 7.05±0.25 | 6.95±0.25 | 19.5 | 9.95±0.25 | 5.1 |
| PC47EF32-Z | DIN 41985 | | 1 | 32.1±0.8 | 16.1±0.3 | 9.15±0.35 | 9.2±0.3 | 22.7 | 11.6±0.3 | 4.4 |
| PC47EE35/28B-Z | U.S. EE-375 | | 1 | 34.6±0.5 | 14.27±0.37 | 9.31±0.30 | 9.4±0.3 | 25.0 | 9.78±0.25 | 4.5 |
| PC47EE35-Z | JIS FEE35B | | 1 | 34.54±1.0 | 14.35±0.35 | 9.53±0.38 | 9.39±0.27 | 24.89 | 9.71±0.28 | 4.75 |
| PC47EE40-Z | JIS FEE40A | | 1 | 40.0±0.5 | 17.0±0.3 | 10.7±0.3 | 10.7±0.3 | 27.4 | 10.25±0.25 | 6.0 |
| PC47EE41/33C-Z | U.S. EE-21 | | 1 | 41.07±0.8 | 16.78±0.4 | 12.57±0.38 | 12.64±0.45 | 28.55 | 10.38±0.3 | 6.0 |
| PC47EE42/42/15-Z | DIN 41295 | JIS FEE42A | 1 | 42.15±0.85 | 21.0±0.2 | 14.95±0.25 | 11.95±0.25 | 29.5 | 15.15±0.35 | 6.025 |

| Part No. | Effective parameter | | | | | Electrical characteristics | | |
|------------------|--------------------------------------|--|---|---|---------------|--|--|---|
| | Core factor $C_1(\text{mm}^{-1})$ | Effective cross-sectional area $A_e(\text{mm}^2)$ | Effective magnetic path length $\ell_e(\text{mm})$ | Effective core volume $V_e(\text{mm}^3)$ | Weight (g) | AL-value (nH/N ²) 1kHz 0.5mA 100Ts Without air gap With air gap | | Core loss (W) max. 100kHz 200mT 100°C |
| PC47EE30/30/7-Z | 1.12 | 59.7 | 66.9 | 4000 | 22 | 2100±25% 160±5% 250±7% | | 1.41 |
| PC47EF32-Z | 0.893 | 83.2 | 74.3 | 6180 | 32 | 2590±25% 160±5% 250±7% | | 2.09 |
| PC47EE35/28B-Z | 0.819 | 84.9 | 69.6 | 5907 | 28 | 2950±25% 200±5% 400±7% | | 2.02 |
| PC47EE35-Z | 0.774 | 89.3 | 69.2 | 6179 | 57 | 3170±25% 200±5% 400±7% | | 2.14 |
| PC47EE40-Z | 0.606 | 128 | 77.3 | 9890 | 50 | 4150±25% 200±5% 400±7% | | 3.10 |
| PC47EE41/33C-Z | 0.495 | 157 | 77.6 | 12200 | 64 | 5060±25% 200±5% 400±7% | | 4.10 |
| PC47EE42/42/15-Z | 0.534 | 182 | 97.0 | 17600 | 80 | 4700±25% 250±5% 400±7% | | 5.94 |

⚠ Please be sure to request delivery specifications that provide further details on the features and specifications of the products for proper and safe use. Please note that the contents may change without any prior notice due to reasons such as upgrading.

Mn-Zn EE, EF Cores

SHAPES AND DIMENSIONS

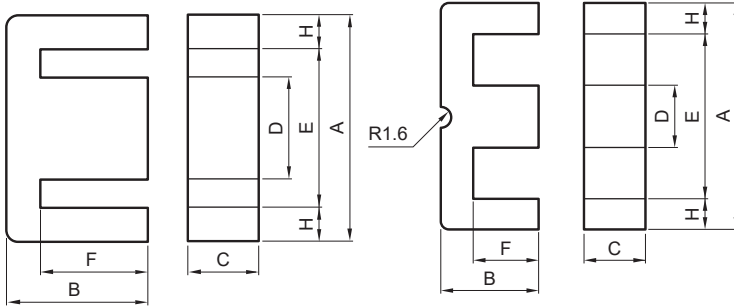
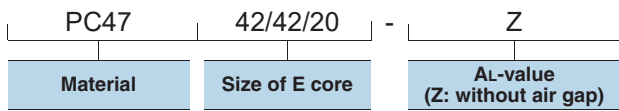

Fig. 1

Fig 2



| Part No. | U.S. lam. cores, DIN standard JIS | | Core | Dimensions (mm) | | | | | | |
|------------------|-----------------------------------|------------|-------|--------------------------------------|------------|------------|------------|-------|------------|-------|
| | A | B | | C | D | E min. | F | H | | |
| PC47EE42/42/20-Z | DIN 41295 | JIS FEE42B | 1 | 42.15±0.85 | 21.0±0.2 | 19.7±0.3 | 11.95±0.25 | 29.5 | 15.15±0.35 | 6.025 |
| PC47EE47/39-Z | U.S. EE-625 | | Fig.1 | 47.12±0.48 | 19.63±0.2 | 15.62±0.25 | 15.62±0.25 | 31.72 | 12.2±0.13 | 7.49 |
| PC47EE50-Z | JIS FEE50A | | Fig.1 | 50.0 ^{+1.0} _{-0.7} | 21.3±0.3 | 14.6±0.4 | 14.6±0.4 | 34.2 | 12.75±0.25 | 7.5 |
| PC47EE55/55/21-Z | DIN 41295 | JIS FEE55 | Fig.1 | 55.15±1.05 | 27.5±0.3 | 20.7±0.3 | 16.95±0.25 | 37.5 | 18.8±0.3 | 8.53 |
| PC47EE57/47-Z | U.S. EE-75 | | Fig.1 | 56.57±1.0 | 23.60±0.23 | 18.8±0.25 | 18.80±0.25 | 38.1 | 14.63±0.15 | 9.02 |
| PC47EE60-Z | JIS FEE60A | | Fig.1 | 60.0 ^{+1.1} _{-0.8} | 22.3±0.3 | 15.6±0.4 | 15.6±0.4 | 43.8 | 14.05±0.25 | 7.7 |

| Part No. | Effective parameter | | | | | Electrical characteristics | | |
|------------------|---|---|---|--|---------------|--|------------------|---|
| | Core factor C ₁ (mm ⁻¹) | Effective cross-sectional area A _e (mm ²) | Effective magnetic path length ℓ _e (mm) | Effective core volume V _e (mm ³) | Weight (g) | AL-value (nH/N ²) 1kHz 0.5mA 100Ts Without air gap With air gap | | Core loss (W) max. 100kHz 200mT 100°C |
| PC47EE42/42/20-Z | 0.415 | 235 | 97.4 | 22900 | 116 | 6100±25% | 250±5% 400±7% | 9.65 |
| PC47EE47/39-Z | 0.374 | 242 | 90.6 | 21930 | 108 | 6660±25% | 250±5% 400±7% | 9.04 |
| PC47EE50-Z | 0.425 | 226 | 95.8 | 21600 | 116 | 6110±25% | 250±5% 500±7% | 8.78 |
| PC47EE55/55/21-Z | 0.348 | 354 | 123 | 43700 | 234 | 7100±25% | 250±5% 400±7% | 18.51 |
| PC47EE57/47-Z | 0.297 | 344 | 102 | 35100 | 190 | 8530±25% | 250±5% 400±7% | 14.79 |
| PC47EE60-Z | 0.446 | 247 | 110 | 27100 | 135 | 5670±25% | 250±5% 500±7% | 11.35 |

⚠ Please be sure to request delivery specifications that provide further details on the features and specifications of the products for proper and safe use. Please note that the contents may change without any prior notice due to reasons such as upgrading.

Mn-Zn E series Part No.: PC47EE10/11-Z

SHAPES AND DIMENSIONS

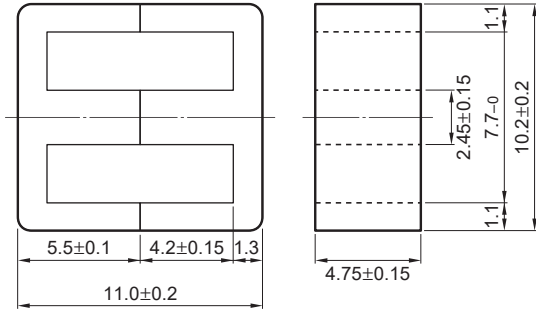

Dimensions in mm

Based on JIS FEE 10.2.

| Effective parameter | | | | | | | | Electrical characteristics | | |
|------------------------|--|---|--|--|---|--|----------------|----------------------------|-----------------|--------------------------|
| Core factor | Effective magnetic path length ℓ_e (mm) | Effective cross-sectional area A_e (mm ²) | Effective core volume V_e (mm ³) | Cross-sectional center pole area A_{cp} (mm ²) | Minimum cross-sectional center pole area $A_{cp \text{ min.}}$ (mm ²) | Cross-sectional winding area of core A_{cw} (mm ²) | Weight (g/set) | AL-value * | | Core loss |
| C1 (mm ⁻¹) | | | | | | | | (nH/N ²) | | (W)max. |
| 2.16 | 26.1 | 12.1 | 315 | 11.6 | 10.6 | 23.3 | 1.5 | 1kHz 0.5mA | 100kHz 200mT | 100kHz 200mT 100°C |
| | | | | | | | | 850±25% | 1450 min. | 0.12 |

* Coil : $\phi 0.18$ 2UEW 100Ts

○ Calculated output power (forward converter mode): 12.1W (100kHz)

NI limit vs. AL-value (Typ.)

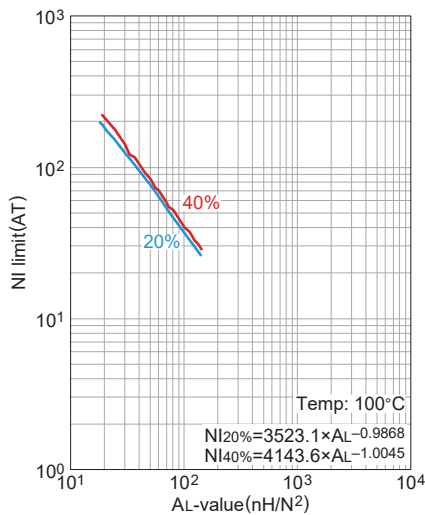

The 20% and 40% graph shows when a 20% and 40% drop from the initial AL-value has been made due to the DC superimposition.

AL-value vs. Air gap length (Typ.)

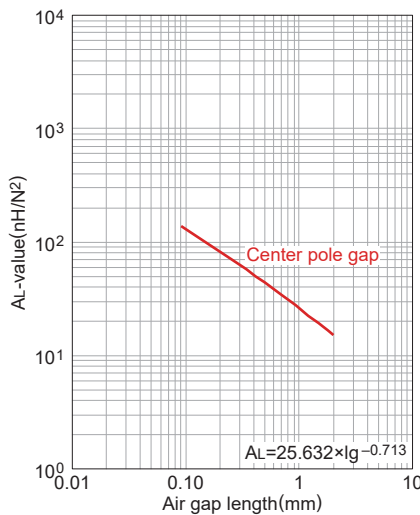

Measuring conditions
 • Coil : $\phi 0.18$ 2UEW 100Ts
 • Frequency : 1kHz
 • Current level : 0.5mA
 • Ambient temperature : 25°C

Temperature rise vs. Total loss (Typ.)

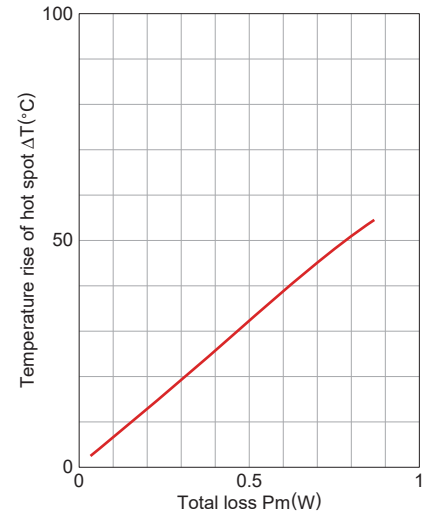

Measuring conditions
 • Room space: approx. 400x300x 300cm
 • Ambient temperature : 25°C
 • Humidity : 45(%RH).

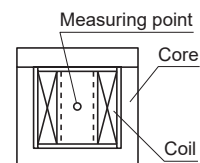

⚠ Please be sure to request delivery specifications that provide further details on the features and specifications of the products for proper and safe use. Please note that the contents may change without any prior notice due to reasons such as upgrading.

Mn-Zn E series Part No.: PC47EE13-Z

SHAPES AND DIMENSIONS

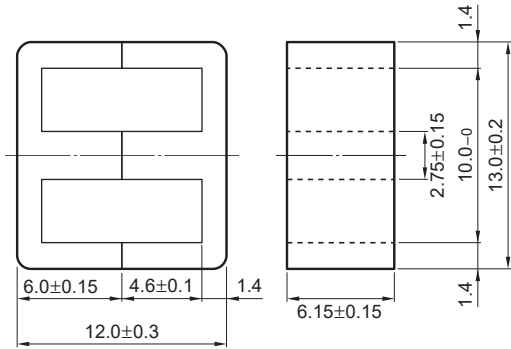

Dimensions in mm

Based on JIS FEI 12.5.

| Effective parameter | | | | | | | | Electrical characteristics | | |
|------------------------|--|---|--|--|---|--|----------------|----------------------------|-----------------|--------------------------|
| Core factor | Effective magnetic path length ℓ_e (mm) | Effective cross-sectional area A_e (mm ²) | Effective core volume V_e (mm ³) | Cross-sectional center pole area A_{cp} (mm ²) | Minimum cross-sectional center pole area $A_{cp \text{ min.}}$ (mm ²) | Cross-sectional winding area of core A_{cw} (mm ²) | Weight (g/set) | AL-value * | | Core loss |
| C1 (mm ⁻¹) | | | | | | | | (nH/N ²) | | (W)max. |
| 1.77 | 30.2 | 17.1 | 517 | 16.9 | 15.6 | 34.3 | 2.7 | 1kHz 0.5mA | 100kHz 200mT | 100kHz 200mT 100°C |
| | | | | | | | | 1130±25% | 1770 min. | 0.22 |

* Coil : $\phi 0.18$ 2UEW 100Ts

○ Calculated output power (forward converter mode): 25W (100kHz)

NI limit vs. AL-value (Typ.)

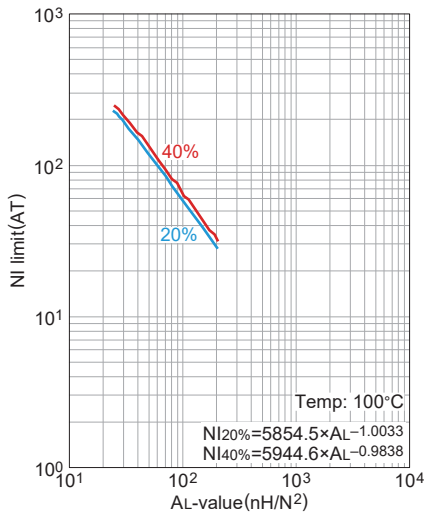

The 20% and 40% graph shows when a 20% and 40% drop from the initial AL-value has been made due to the DC superimposition.

AL-value vs. Air gap length (Typ.)

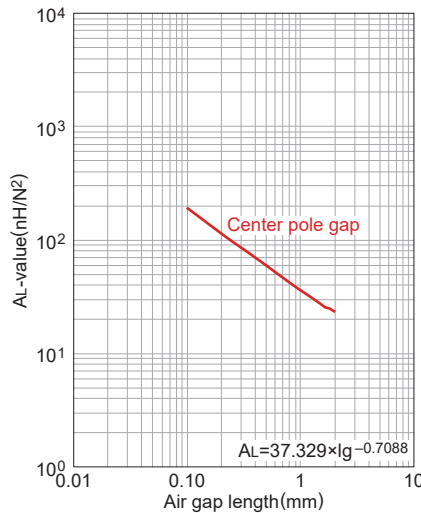

Measuring conditions
 • Coil : $\phi 0.18$ 2UEW 100Ts
 • Frequency : 1kHz
 • Current level : 0.5mA
 • Ambient temperature : 25°C

Temperature rise vs. Total loss (Typ.)

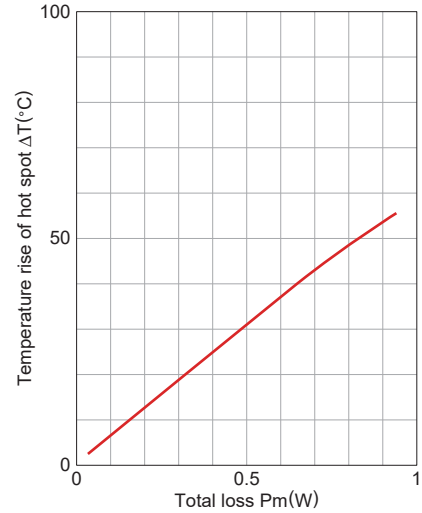

Measuring conditions
 • Room space: approx. 400x300x 300cm
 • Ambient temperature : 25°C
 • Humidity : 45(%RH).

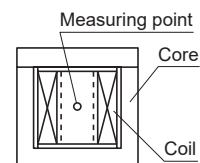

⚠ Please be sure to request delivery specifications that provide further details on the features and specifications of the products for proper and safe use. Please note that the contents may change without any prior notice due to reasons such as upgrading.

Mn-Zn E series Part No.: PC47EE16-Z

SHAPES AND DIMENSIONS

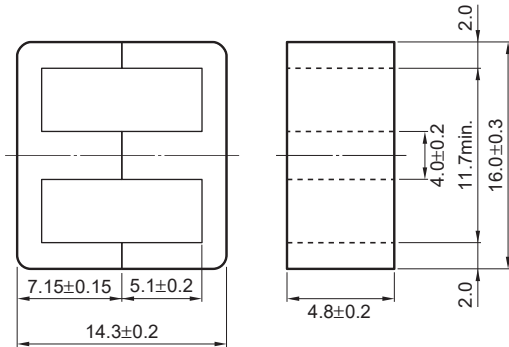

Dimensions in mm

| Effective parameter | | | | | | | | Electrical characteristics | | |
|------------------------|--|---|--|--|---|--|----------------|----------------------------|-----------------|--------------------------|
| Core factor | Effective magnetic path length ℓ_e (mm) | Effective cross-sectional area A_e (mm ²) | Effective core volume V_e (mm ³) | Cross-sectional center pole area A_{cp} (mm ²) | Minimum cross-sectional center pole area $A_{cp \text{ min.}}$ (mm ²) | Cross-sectional winding area of core A_{cw} (mm ²) | Weight (g/set) | AL-value * | | Core loss |
| C1 (mm ⁻¹) | | | | | | | | (nH/N ²) | | (W)max. |
| 1.82 | 34.5 | 19.0 | 656 | 19.2 | 17.5 | 41.4 | 3.3 | 1kHz 0.5mA | 100kHz 200mT | 100kHz 200mT 100°C |
| | | | | | | | | 1140±25% | | 0.28 |

* Coil : ø0.18 2UEW 100Ts

○ Calculated output power (forward converter mode): 32W (100kHz)

NI limit vs. AL-value (Typ.)

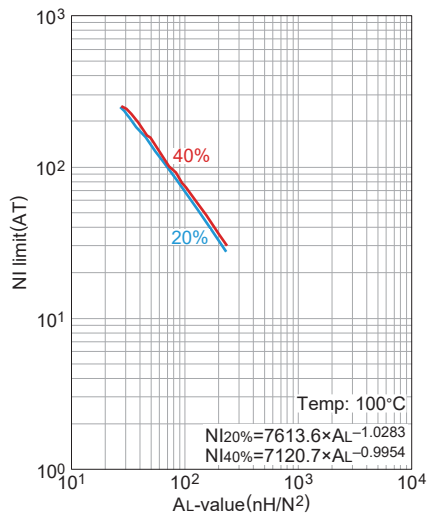

The 20% and 40% graph shows when a 20% and 40% drop from the initial AL-value has been made due to the DC superimposition.

AL-value vs. Air gap length (Typ.)

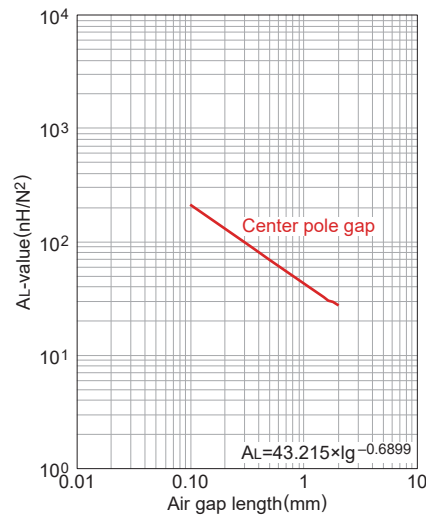

Measuring conditions
 • Coil : ø0.18 2UEW 100Ts
 • Frequency : 1kHz
 • Current level : 0.5mA
 • Ambient temperature : 25°C

Mn-Zn E series Part No.: PC47EE19-Z

SHAPES AND DIMENSIONS

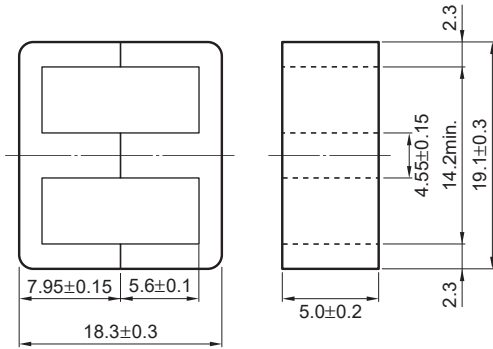

Dimensions in mm

| Effective parameter | | | | | | | | Electrical characteristics | | |
|---------------------|---|---|--|--|---|--|----------------|----------------------------|-----------------|--------------------------|
| Core factor | Effective magnetic path length l_e (mm) | Effective cross-sectional area A_e (mm ²) | Effective core volume V_e (mm ³) | Cross-sectional center pole area A_{cp} (mm ²) | Minimum cross-sectional center pole area $A_{cp \text{ min.}}$ (mm ²) | Cross-sectional winding area of core A_{cw} (mm ²) | Weight (g/set) | AL-value * | | Core loss |
| C ₁ | (mm ⁻¹) | | | | | | | (nH/N ²) | | (W)max. |
| 1.71 | 39.4 | 23.0 | 906 | 22.8 | 21.1 | 55.8 | 4.8 | 1kHz 0.5mA | 100kHz 200mT | 100kHz 200mT 100°C |
| | | | | | | | | 1250±25% | | 0.39 |

* Coil : ø0.18 2UEW 100Ts

○ Calculated output power (forward converter mode): 45W (100kHz)

NI limit vs. AL-value (Typ.)

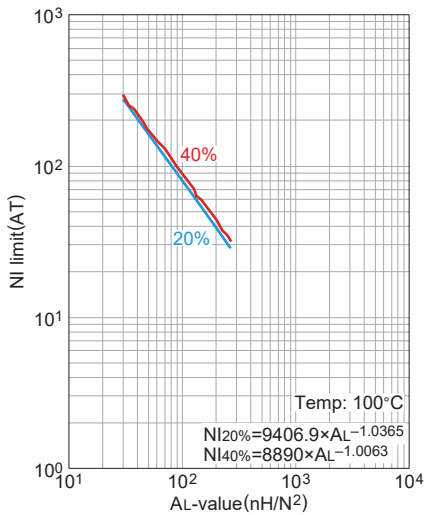

The 20% and 40% graph shows when a 20% and 40% drop from the initial AL-value has been made due to the DC superimposition.

AL-value vs. Air gap length (Typ.)

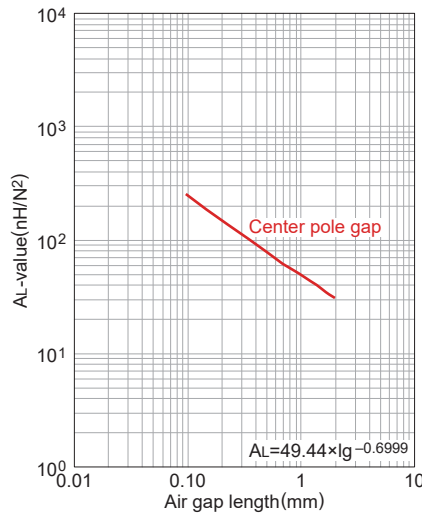

Measuring conditions
 • Coil : ø0.18 2UEW 100Ts
 • Frequency : 1kHz
 • Current level : 0.5mA
 • Ambient temperature : 25°C

⚠ Please be sure to request delivery specifications that provide further details on the features and specifications of the products for proper and safe use. Please note that the contents may change without any prior notice due to reasons such as upgrading.

Mn-Zn E series Part No.: PC47EE25/19-Z

SHAPES AND DIMENSIONS

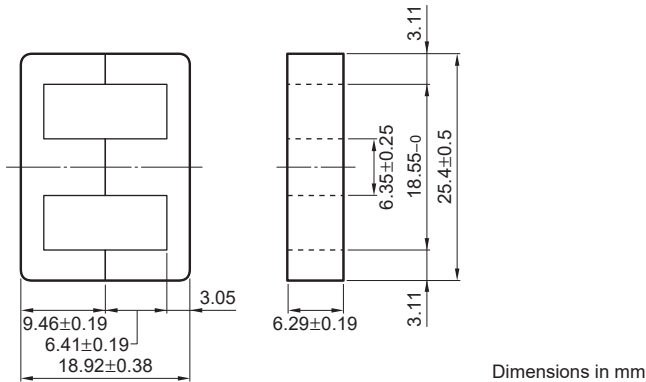

| Effective parameter | | | | | | | | Electrical characteristics | | |
|---------------------|---|---|--|--|---|--|----------------|----------------------------|-----------|--------------------------|
| Core factor | Effective magnetic path length l_e (mm) | Effective cross-sectional area A_e (mm ²) | Effective core volume V_e (mm ³) | Cross-sectional center pole area A_{cp} (mm ²) | Minimum cross-sectional center pole area $A_{cp \text{ min.}}$ (mm ²) | Cross-sectional winding area of core A_{cw} (mm ²) | Weight (g/set) | AL-value * | | Core loss |
| C_1 | (mm ⁻¹) | (mm) | (mm ³) | (mm ²) | (mm ²) | (mm ²) | (g/set) | (nH/N ²) | | (W)max. |
| 1.22 | 48.7 | 40.0 | 1950 | 39.9 | 37.2 | 79.0 | 9.1 | 2000±25% | 2570 min. | 100kHz 200mT 100°C |

* Coil : ø0.23 2UEW 100Ts

○ Calculated output power (forward converter mode): 93W (100kHz)

NI limit vs. AL-value (Typ.)

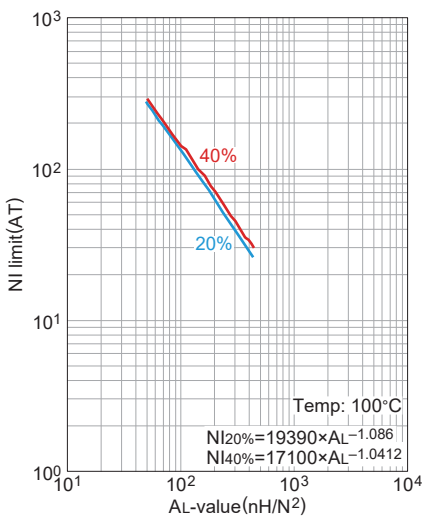

The 20% and 40% graph shows when a 20% and 40% drop from the initial AL-value has been made due to the DC superimposition.

AL-value vs. Air gap length (Typ.)

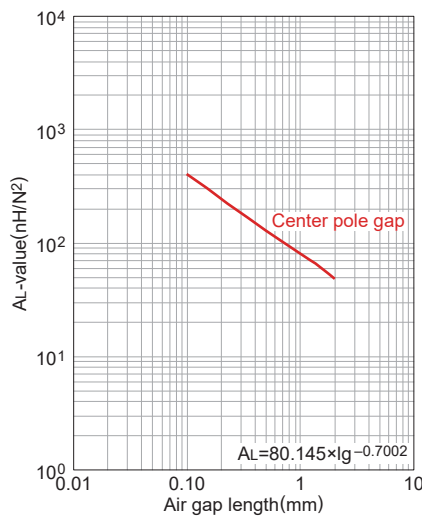

Measuring conditions
 • Coil : ø0.23 2UEW 100Ts
 • Frequency : 1kHz
 • Current level : 0.5mA
 • Ambient temperature : 25°C

Temperature rise vs. Total loss (Typ.)

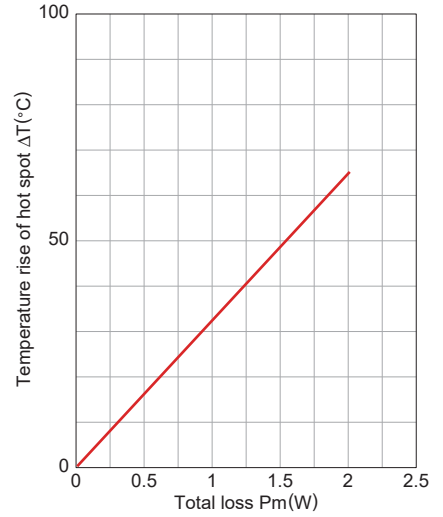

Measuring conditions
 • Room space: approx. 400x300x 300cm
 • Ambient temperature : 25°C
 • Humidity: 45(%RH).

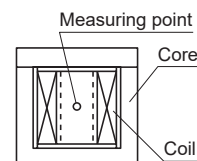

⚠ Please be sure to request delivery specifications that provide further details on the features and specifications of the products for proper and safe use. Please note that the contents may change without any prior notice due to reasons such as upgrading.

Mn-Zn E series Part No.: PC47EE30-Z

SHAPES AND DIMENSIONS

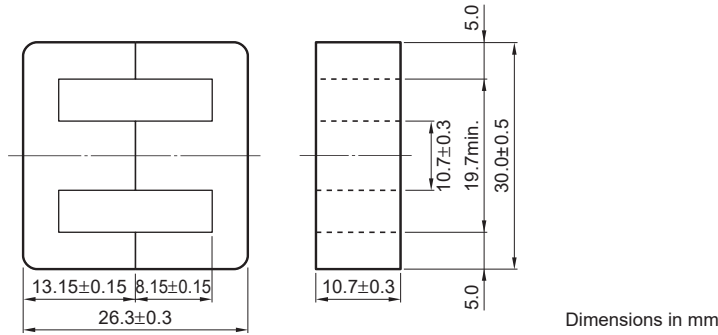

Dimensions in mm

Based on DIN 41295.

| Effective parameter | | | | | | | | Electrical characteristics | | |
|---------------------------|--|---|--|--|---|--|----------------|---------------------------------------|-----------------|-------------------------------------|
| Core factor | Effective magnetic path length ℓ_e (mm) | Effective cross-sectional area A_e (mm ²) | Effective core volume V_e (mm ³) | Cross-sectional center pole area A_{cp} (mm ²) | Minimum cross-sectional center pole area $A_{cp \text{ min.}}$ (mm ²) | Cross-sectional winding area of core A_{cw} (mm ²) | Weight (g/set) | AL-value * | | Core loss |
| C_1 (mm ⁻¹) | | | | | | | | (nH/N ²) 1kHz 0.5mA | 100kHz 200mT | (W)max. 100kHz 200mT 100°C |
| 0.529 | 57.7 | 109.9 | 6290 | 114 | 108 | 75.8 | 32 | 4690±25% | | 2.03 |

* Coil : $\phi 0.35$ 2UEW 100Ts

○ Calculated output power (forward converter mode): 203W (100kHz)

NI limit vs. AL-value (Typ.)

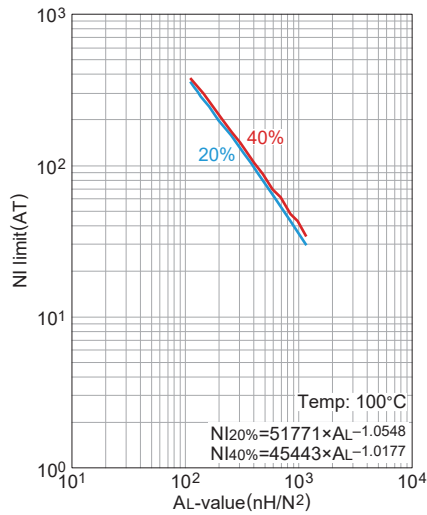

The 20% and 40% graph shows when a 20% and 40% drop from the initial AL-value has been made due to the DC superimposition.

AL-value vs. Air gap length (Typ.)

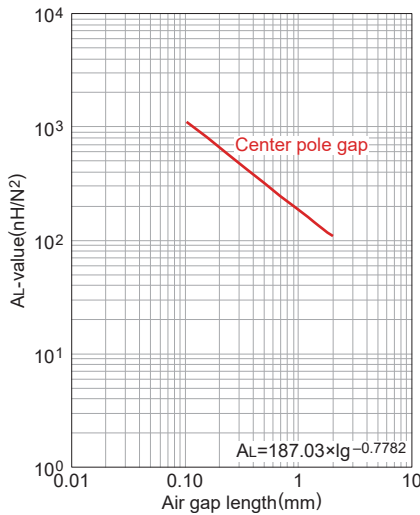

Measuring conditions
 • Coil : $\phi 0.35$ 2UEW 100Ts
 • Frequency : 1kHz
 • Current level : 0.5mA
 • Ambient temperature : 25°C

Mn-Zn E series Part No.: PC47EE40-Z

SHAPES AND DIMENSIONS

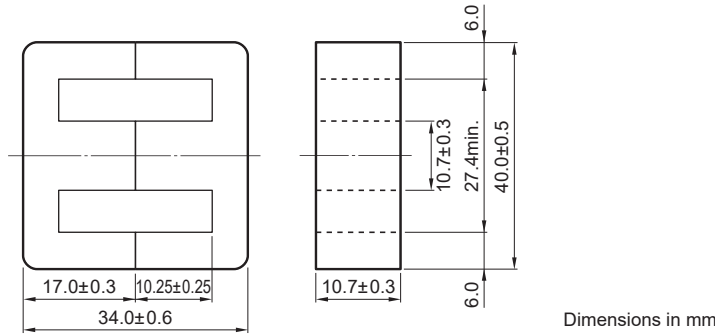

| Effective parameter | | | | | | | | Electrical characteristics | | |
|------------------------|--|---|--|--|---|--|----------------|----------------------------|-----------------|--------------------------|
| Core factor | Effective magnetic path length ℓ_e (mm) | Effective cross-sectional area A_e (mm ²) | Effective core volume V_e (mm ³) | Cross-sectional center pole area A_{cp} (mm ²) | Minimum cross-sectional center pole area $A_{cp \text{ min.}}$ (mm ²) | Cross-sectional winding area of core A_{cw} (mm ²) | Weight (g/set) | AL-value * | | Core loss |
| C1 (mm ⁻¹) | | | | | | | | (nH/N ²) | | (W)max. |
| 0.060 | 77.3 | 128 | 9890 | 114 | 108 | 164 | 50 | 1kHz 0.5mA | 100kHz 200mT | 100kHz 200mT 100°C |
| | | | | | | | | 4150±25% | | 3.1 |

* Coil : ø0.18 2UEW 100Ts

○ Calculated output power (forward converter mode): 311W (100kHz)

NI limit vs. AL-value (Typ.)

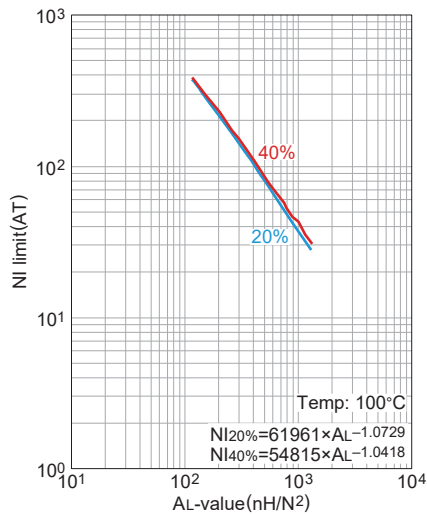

The 20% and 40% graph shows when a 20% and 40% drop from the initial AL-value has been made due to the DC superimposition.

AL-value vs. Air gap length (Typ.)

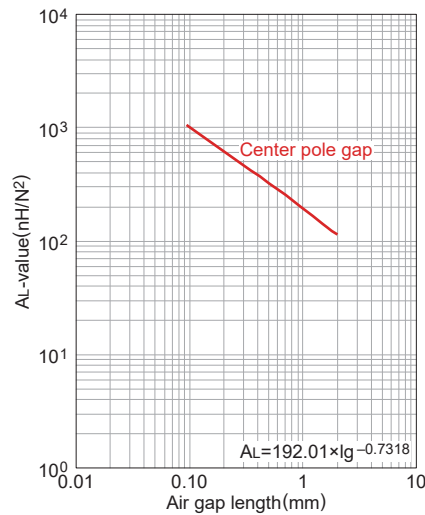

Measuring conditions

- Coil : ø0.18 2UEW 100Ts
- Frequency : 1kHz
- Current level : 0.5mA
- Ambient temperature : 25°C

⚠ Please be sure to request delivery specifications that provide further details on the features and specifications of the products for proper and safe use. Please note that the contents may change without any prior notice due to reasons such as upgrading.

Mn-Zn E series Part No.: PC47EE50-Z

SHAPES AND DIMENSIONS

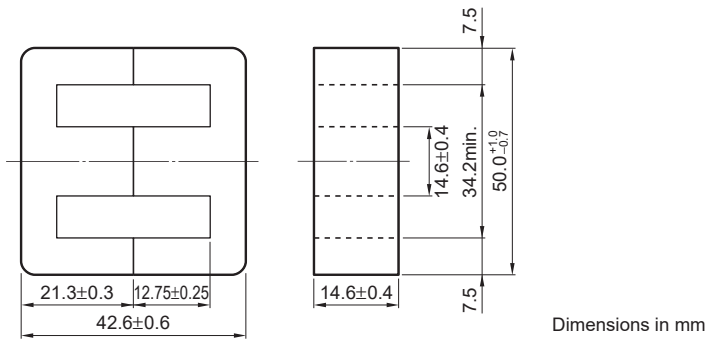

| Effective parameter | | | | | | | | Electrical characteristics | | |
|------------------------------------|--|---|--|--|---|--|----------------|---------------------------------------|-----------------|-------------------------------------|
| Core factor | Effective magnetic path length ℓ_e (mm) | Effective cross-sectional area A_e (mm ²) | Effective core volume V_e (mm ³) | Cross-sectional center pole area A_{cp} (mm ²) | Minimum cross-sectional center pole area $A_{cp \text{ min.}}$ (mm ²) | Cross-sectional winding area of core A_{cw} (mm ²) | Weight (g/set) | AL-value * | | Core loss |
| C ₁ (mm ⁻¹) | | | | | | | | (nH/N ²) 1kHz 0.5mA | 100kHz 200mT | (W)max. 100kHz 200mT 100°C |
| 0.425 | 95.8 | 226 | 21600 | 213 | 202 | 262 | 116 | 6110±25% | | 8.78 |

* Coil : ø0.18 2UEW 100Ts

○ Calculated output power (forward converter mode): 556W (100kHz)

NI limit vs. AL-value (Typ.)

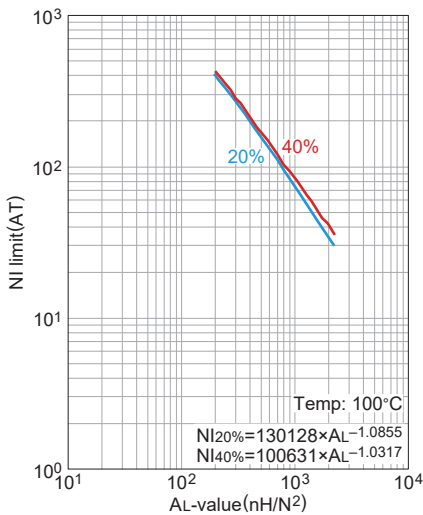

The 20% and 40% graph shows when a 20% and 40% drop from the initial AL-value has been made due to the DC superimposition.

AL-value vs. Air gap length (Typ.)

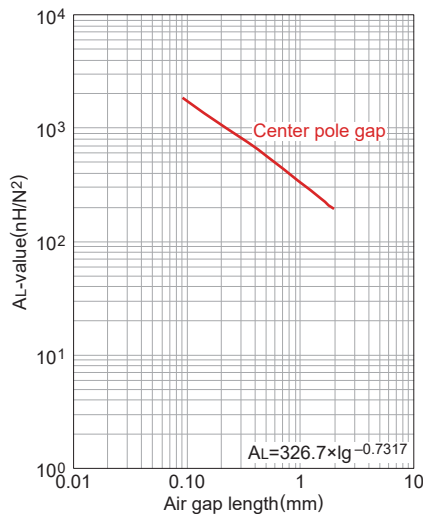

Measuring conditions

- Coil : ø0.18 2UEW 100Ts
- Frequency : 1kHz
- Current level : 0.5mA
- Ambient temperature : 25°C

Mn-Zn E series Part No.: PC47EE60-Z

SHAPES AND DIMENSIONS

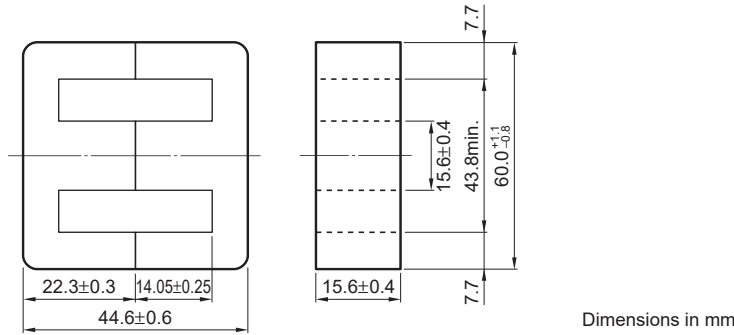

| Effective parameter | | | | | | | | Electrical characteristics | | |
|------------------------|--|---|--|--|---|--|----------------|----------------------------|--------|-----------|
| Core factor | Effective magnetic path length ℓ_e (mm) | Effective cross-sectional area A_e (mm ²) | Effective core volume V_e (mm ³) | Cross-sectional center pole area A_{cp} (mm ²) | Minimum cross-sectional center pole area $A_{cp \text{ min.}}$ (mm ²) | Cross-sectional winding area of core A_{cw} (mm ²) | Weight (g/set) | AL-value * | | Core loss |
| C1 (mm ⁻¹) | | | | | | | | (nH/N ²) | | (W)max. |
| | | | | | | | | 1kHz | 100kHz | 100kHz |
| | | | | | | | | 0.5mA | 200mT | 200mT |
| | | | | | | | | | | 100°C |
| 0.446 | 110 | 247 | 27100 | 243 | 231 | 407 | 135 | 5670±25% | | 11.35 |

* Coil : ø0.18 2UEW 100Ts

○ Calculated output power (forward converter mode): 713W (100kHz)

NI limit vs. AL-value (Typ.)

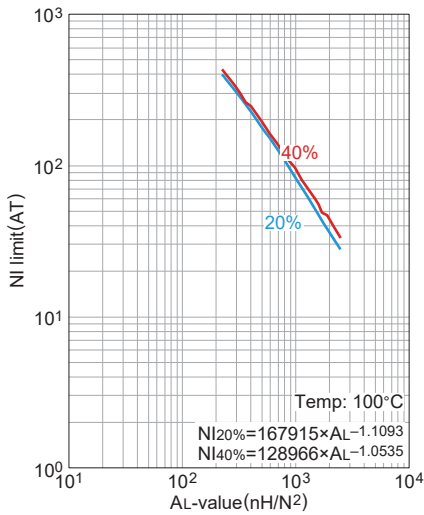

The 20% and 40% graph shows when a 20% and 40% drop from the initial AL-value has been made due to the DC superimposition.

AL-value vs. Air gap length (Typ.)

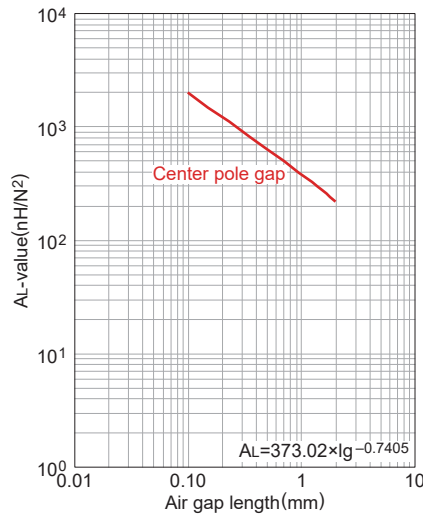

Measuring conditions

- Coil : ø0.18 2UEW 100Ts
- Frequency : 1kHz
- Current level : 0.5mA
- Ambient temperature : 25°C

Mn-Zn EER Cores



SHAPES AND DIMENSIONS

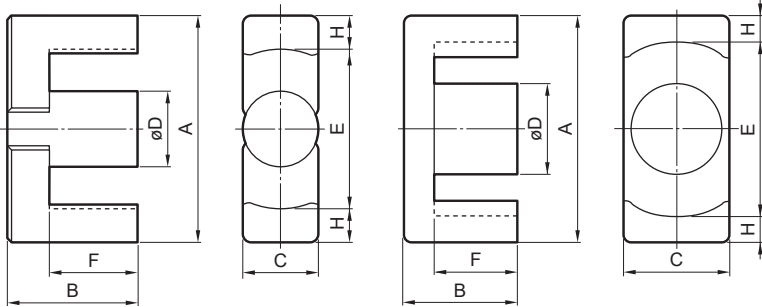
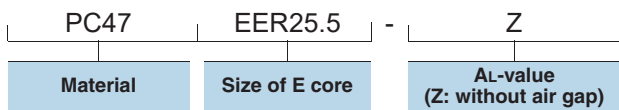

Fig. 1

Fig. 2



| Part No. | U.S. lam. cores, DIN standard JIS | Core | Dimensions (mm) | | | | | | |
|--------------------------------|---|-------|--------------------|-----------|-----------|-----------|--------|------------|------|
| | | | A | B | C | øD | E min. | F | H |
| PC47EER25.5-Z PC95EER25.5-Z | JIS FEER25.5A | Fig.1 | 25.5±0.5 | 9.3±0.2 | 7.5±0.2 | 7.5±0.15 | 19.8 | 6.2±0.2 | 2.6 |
| PC47EER28-Z PC95EER28-Z | JIS FEER28.5A | Fig.2 | 28.55±0.55 | 14.0±0.2 | 11.4±0.25 | 9.9±0.25 | 21.2 | 9.65±0.25 | 3.4 |
| PC47EER28L-Z PC95EER28L-Z | JIS FEER28.5B | Fig.2 | 28.55±0.55 | 16.9±0.25 | 11.4±0.25 | 9.9±0.25 | 21.2 | 12.53±0.28 | 3.4 |
| PC47EER35-Z PC95EER35-Z | JIS FEER35A | Fig.1 | 35.0±0.5 | 20.7±0.2 | 11.3±0.2 | 11.3±0.15 | 25.6 | 14.7±0.3 | 4.43 |
| PC47EER40-Z PC95EER40-Z | | Fig.1 | 40.0±0.5 | 22.4±0.2 | 13.3±0.25 | 13.3±0.25 | 29.0 | 15.4±0.3 | 5.28 |
| PC47EER42-Z | JIS FEER42 | Fig.1 | 42.0±0.6 | 22.4±0.2 | 15.5±0.25 | 15.5±0.25 | 29.4 | 15.4±0.3 | 6.0 |
| PC47EER42/42/20-Z | | Fig.2 | 42.15±0.65 | 21.2±0.2 | 19.60±0.4 | 17.3±0.25 | 31.8 | 15.25±0.25 | 4.93 |
| PC47EER49-Z | | Fig.1 | 49.0±0.8 | 19.0±0.3 | 17.2±0.4 | 17.2±0.25 | 36.4 | 12.4±0.2 | 6.0 |

| Part No. | Effective parameter | | | | | Electrical characteristics | | | | | |
|--------------------------------|---|---|---|--|--------------|---|------------------|-----------------------------|-----------|-----------|-----------|
| | Core factor C ₁ (mm ⁻¹) | Effective cross-sectional area A _e (mm ²) | Effective magnetic path length ℓ _e (mm) | Effective core volume V _e (mm ³) | Weigh (g) | AL-value | | Core loss | | | |
| | | | | | | (nH/N ²) 1kHz 0.5mA 100Ts Without air gap | With air gap | (W) max. 100kHz 200mT | 100°C | 25°C | 80°C |
| PC47EER25.5-Z PC95EER25.5-Z | 1.08 | 44.8 | 48.2 | 2160 | 11 | 1920±25% 2700±25% | 100±5% 200±7% | 0.75 — | — 1.1 | — 0.9 | — 1.1 |
| PC47EER28-Z PC95EER28-Z | 0.780 | 82.1 | 64.0 | 5250 | 28 | 2870±25% 4000±25% | 200±5% 400±7% | 1.72 — | — 2.45 | — 2.1 | — 2.45 |
| PC47EER28L-Z PC95EER28L-Z | 0.928 | 81.4 | 75.5 | 6150 | 33 | 2520±25% 3500±25% | 160±5% 315±7% | 2.03 — | — 2.9 | — 2.45 | — 2.9 |
| PC47EER35-Z PC95EER35-Z | 0.849 | 107 | 90.8 | 9720 | 52 | 2770±25% 4000±25% | 200±5% 400±7% | 3.18 — | — 4.55 | — 3.8 | — 4.55 |
| PC47EER40-Z PC95EER40-Z | 0.658 | 149 | 98.0 | 14600 | 78 | 3620±25% 5200±25% | 200±5% 400±7% | 4.77 — | — 6.8 | — 5.7 | — 6.8 |
| PC47EER42-Z | 0.509 | 194 | 98.8 | 19200 | 102 | 4690±25% | 250±5% 500±7% | 6.47 | — | — | — |
| PC47EER42/42/20-Z | 0.411 | 240 | 98.6 | 23700 | 116 | 5340±25% | 250±5% 500±7% | 9.96 | — | — | — |
| PC47EER49-Z | 0.395 | 231 | 91.3 | 21100 | 110 | 6250±25% | 250±5% 500±7% | 4.03 | — | — | — |

⚠ Please be sure to request delivery specifications that provide further details on the features and specifications of the products for proper and safe use. Please note that the contents may change without any prior notice due to reasons such as upgrading.

Mn-Zn E series Part No.: PC47EER25.5-Z

SHAPES AND DIMENSIONS

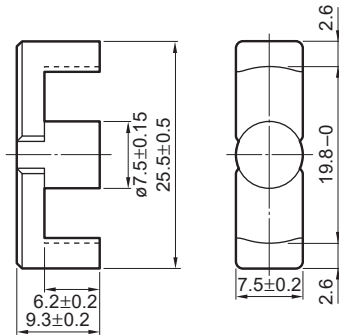

Dimensions in mm

Based on JIS FEER 25.5A.

| Effective parameter | | | | | | | | Electrical characteristics | | |
|------------------------|---|---|--|--|---|--|----------------|----------------------------|-----------------|--------------------------|
| Core factor | Effective magnetic path length l_e (mm) | Effective cross-sectional area A_e (mm ²) | Effective core volume V_e (mm ³) | Cross-sectional center pole area A_{cp} (mm ²) | Minimum cross-sectional center pole area $A_{cp \text{ min.}}$ (mm ²) | Cross-sectional winding area of core A_{cw} (mm ²) | Weight (g/set) | AL-value * | | Core loss |
| C1 (mm ⁻¹) | | | | | | | | (nH/N ²) | | (W)max. |
| 1.08 | 48.2 | 44.8 | 2160 | 44.2 | 42.4 | 79.4 | 11 | 1kHz 0.5mA | 100kHz 200mT | 100kHz 200mT 100°C |
| | | | | | | | | 1920±25% | 2910 min. | 0.75 |

* Coil : ø0.35 2UEW 100Ts

○ Calculated output power (forward converter mode): 112W (100kHz)

NI limit vs. AL-value (Typ.)

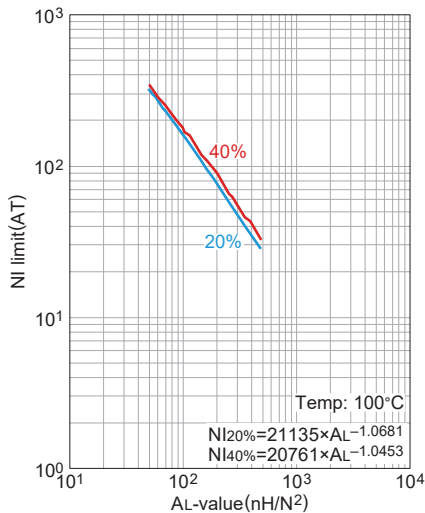

The 20% and 40% graph shows when a 20% and 40% drop from the initial AL-value has been made due to the DC superimposition.

AL-value vs. Air gap length (Typ.)

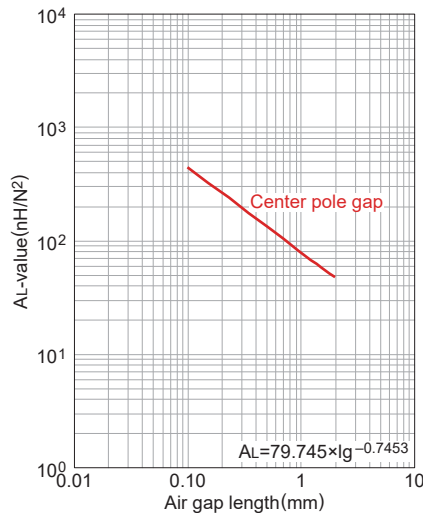

Measuring conditions
 • Coil : ø0.35 2UEW 100Ts
 • Frequency : 1kHz
 • Current level : 0.5mA
 • Ambient temperature : 25°C

Temperature rise vs. Total loss (Typ.)

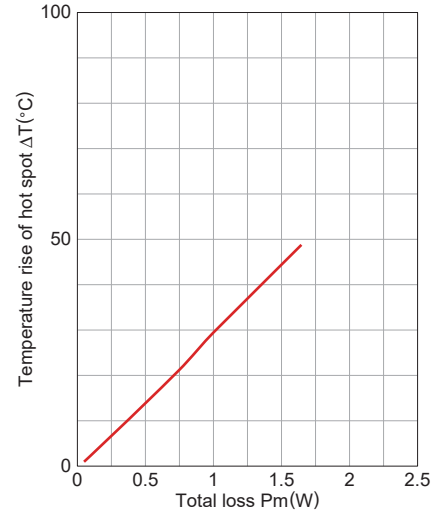

Measuring conditions
 • Room space: approx. 400x300x 300cm
 • Ambient temperature : 25°C
 • Humidity : 45(%RH).

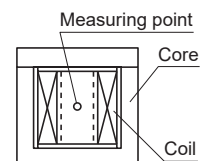

⚠ Please be sure to request delivery specifications that provide further details on the features and specifications of the products for proper and safe use. Please note that the contents may change without any prior notice due to reasons such as upgrading.

Mn-Zn E series Part No.: PC95EER25.5-Z

SHAPES AND DIMENSIONS

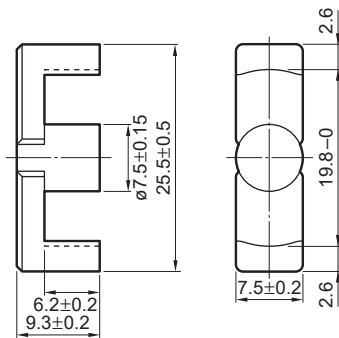

Dimensions in mm

Based on JIS FEER 25.5A.

| Effective parameter | | | | | | | | Electrical characteristics | | | | |
|------------------------|---|---|--|--|---|--|----------------|----------------------------|-----------------|------|------|-------|
| Core factor | Effective magnetic path length l_e (mm) | Effective cross-sectional area A_e (mm ²) | Effective core volume V_e (mm ³) | Cross-sectional center pole area A_{cp} (mm ²) | Minimum cross-sectional center pole area $A_{cp \text{ min.}}$ (mm ²) | Cross-sectional winding area of core A_{cw} (mm ²) | Weight (g/set) | AL-value * | Core loss | | | |
| C1 (mm ⁻¹) | | | | | | | | (nH/N ²) | (W)max. | | | |
| 1.08 | 48.2 | 44.8 | 2160 | 44.2 | 42.4 | 79.4 | 11 | 1kHz 0.5mA | 100kHz 200mT | 25°C | 80°C | 120°C |
| | | | | | | | | 2700±25% | 1.1 | 0.9 | 1.1 | |

* Coil : ø0.35 2UEW 100Ts

○ Calculated output power (forward converter mode): 96W (100kHz)

NI limit vs. AL-value (Typ.)

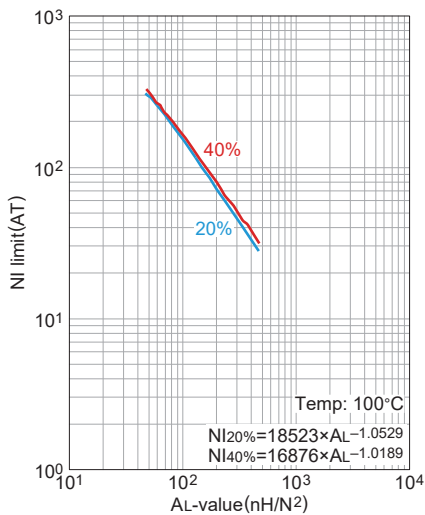

The 20% and 40% graph shows when a 20% and 40% drop from the initial AL-value has been made due to the DC superimposition.

AL-value vs. Air gap length (Typ.)

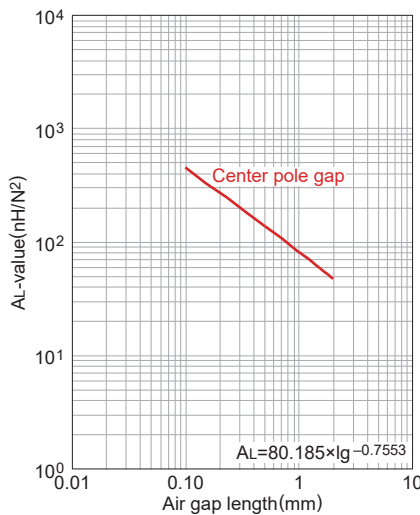

Measuring conditions

- Coil : ø0.35 2UEW 100Ts
- Frequency : 1kHz
- Current level : 0.5mA
- Ambient temperature : 25°C

Temperature rise vs. Total loss (Typ.)

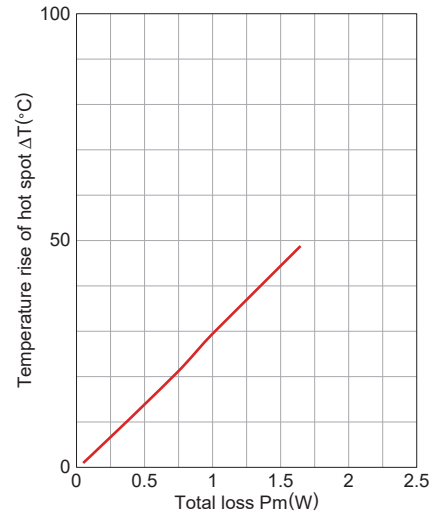

Measuring conditions

- Room space: approx. 400x300x 300cm
- Ambient temperature : 25°C
- Humidity: 45%(%)RH.

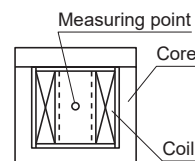

⚠ Please be sure to request delivery specifications that provide further details on the features and specifications of the products for proper and safe use. Please note that the contents may change without any prior notice due to reasons such as upgrading.

Mn-Zn E series Part No.: PC47EER28-Z

SHAPES AND DIMENSIONS

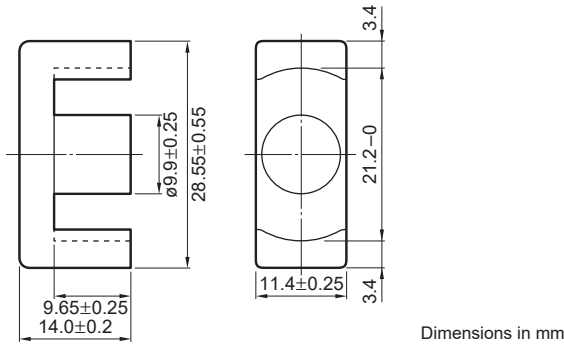

Based on JIS FEER 28.5A.

| Effective parameter | | | | | | | | Electrical characteristics | | |
|------------------------|--|---|--|--|---|--|----------------|----------------------------|-----------------|--------------------------|
| Core factor | Effective magnetic path length ℓ_e (mm) | Effective cross-sectional area A_e (mm ²) | Effective core volume V_e (mm ³) | Cross-sectional center pole area A_{cp} (mm ²) | Minimum cross-sectional center pole area $A_{cp \text{ min.}}$ (mm ²) | Cross-sectional winding area of core A_{cw} (mm ²) | Weight (g/set) | AL-value * | | Core loss |
| C1 (mm ⁻¹) | | | | | | | | (nH/N ²) | | (W)max. |
| 0.78 | 64.0 | 82.1 | 5250 | 77.0 | 73.1 | 114 | 28 | 1kHz 0.5mA | 100kHz 200mT | 100kHz 200mT 100°C |
| | | | | | | | | 2870±25% | 4350 min. | 1.72 |

* Coil : $\phi 0.35$ 2UEW 100Ts

○ Calculated output power (forward converter mode): 233W (100kHz)

NI limit vs. AL-value (Typ.)

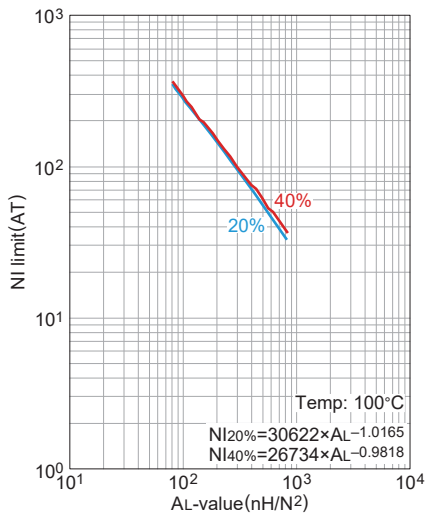

The 20% and 40% graph shows when a 20% and 40% drop from the initial AL-value has been made due to the DC superimposition.

AL-value vs. Air gap length (Typ.)

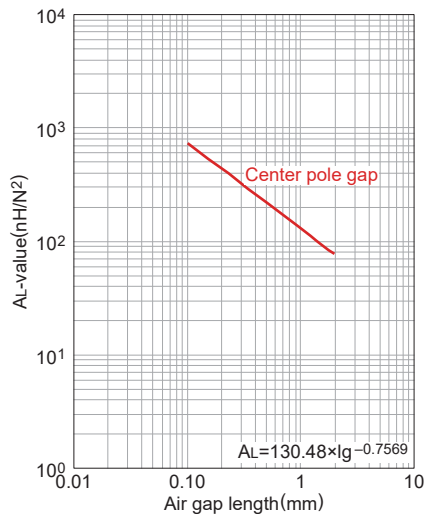

Measuring conditions

- Coil : $\phi 0.35$ 2UEW 100Ts
- Frequency : 1kHz
- Current level : 0.5mA
- Ambient temperature : 25°C

Temperature rise vs. Total loss (Typ.)

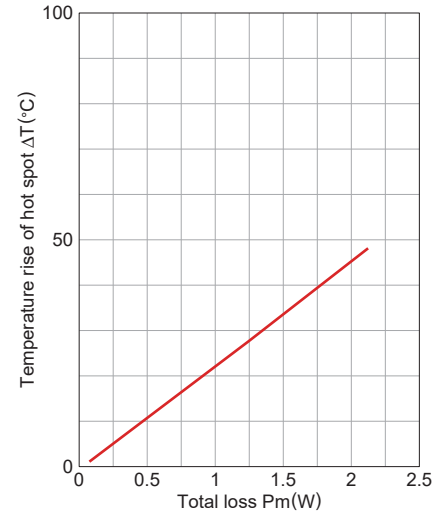

Measuring conditions

- Room space: approx. 400x300x 300cm
- Ambient temperature : 25°C
- Humidity : 45(%)RH.

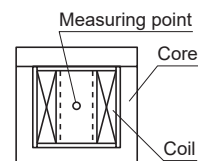

⚠ Please be sure to request delivery specifications that provide further details on the features and specifications of the products for proper and safe use. Please note that the contents may change without any prior notice due to reasons such as upgrading.

Mn-Zn E series Part No.: PC95EER28-Z

SHAPES AND DIMENSIONS

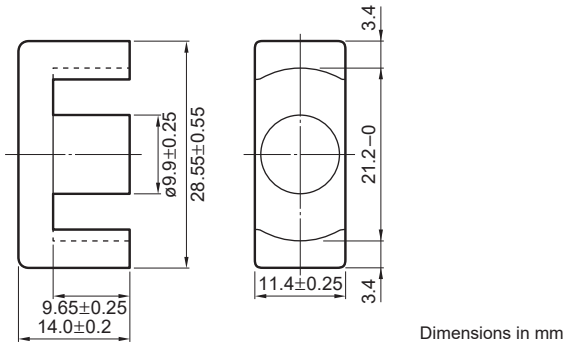

Based on JIS FEER 28.5A.

| Effective parameter | | | | | | | | Electrical characteristics | | | | |
|------------------------|--|---|--|--|---|--|----------------|---------------------------------------|----------------------------|------|------|-------|
| Core factor | Effective magnetic path length ℓ_e (mm) | Effective cross-sectional area A_e (mm ²) | Effective core volume V_e (mm ³) | Cross-sectional center pole area A_{cp} (mm ²) | Minimum cross-sectional center pole area $A_{cp \text{ min.}}$ (mm ²) | Cross-sectional winding area of core A_{cw} (mm ²) | Weight (g/set) | AL-value * | Core loss | | | |
| C1 (mm ⁻¹) | | | | | | | | (nH/N ²) 1kHz 0.5mA | (W)max. 100kHz 200mT | 25°C | 80°C | 120°C |
| 0.78 | 64.0 | 82.1 | 5250 | 77.0 | 73.1 | 114 | 28 | 4000±25% | 2.45 | 2.1 | 2.45 | |

* Coil : $\phi 0.35$ 2UEW 100Ts

○ Calculated output power (forward converter mode): 223W (100kHz)

NI limit vs. AL-value (Typ.)

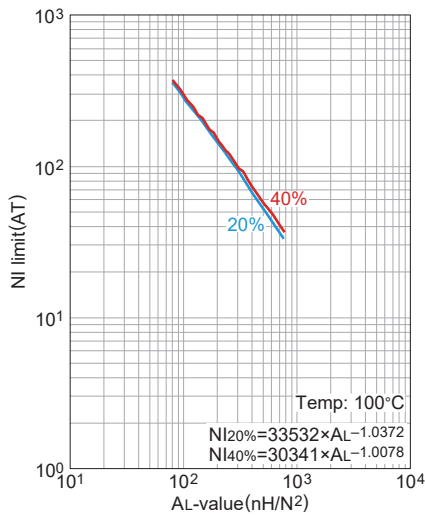

The 20% and 40% graph shows when a 20% and 40% drop from the initial AL-value has been made due to the DC superimposition.

AL-value vs. Air gap length (Typ.)

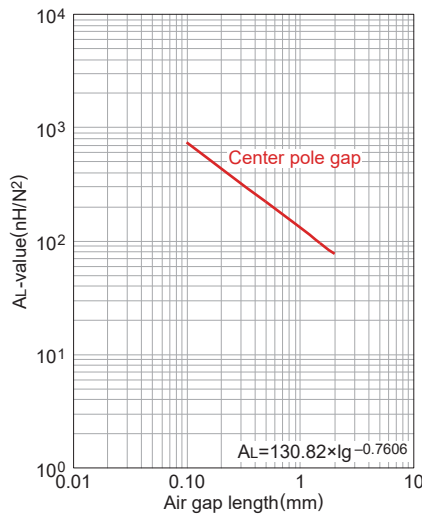

Measuring conditions
 • Coil : $\phi 0.35$ 2UEW 100Ts
 • Frequency : 1kHz
 • Current level : 0.5mA
 • Ambient temperature : 25°C

Temperature rise vs. Total loss (Typ.)

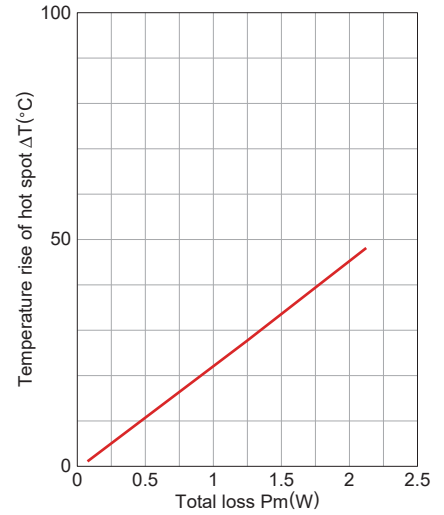

Measuring conditions
 • Room space: approx. 400x300x 300cm
 • Ambient temperature : 25°C
 • Humidity: 45%(%)RH.

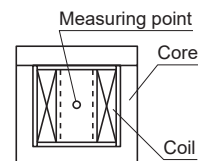

⚠ Please be sure to request delivery specifications that provide further details on the features and specifications of the products for proper and safe use. Please note that the contents may change without any prior notice due to reasons such as upgrading.

Mn-Zn E series Part No.: PC47EER28L-Z

SHAPES AND DIMENSIONS

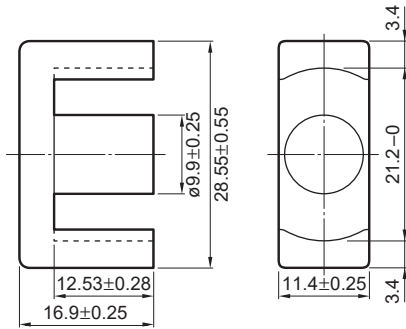

Dimensions in mm

Based on JIS FEER 28.5B.

| Effective parameter | | | | | | | | Electrical characteristics | | |
|------------------------|--|---|--|--|---|--|----------------|----------------------------|-----------------|--------------------------|
| Core factor | Effective magnetic path length ℓ_e (mm) | Effective cross-sectional area A_e (mm ²) | Effective core volume V_e (mm ³) | Cross-sectional center pole area A_{cp} (mm ²) | Minimum cross-sectional center pole area $A_{cp \text{ min.}}$ (mm ²) | Cross-sectional winding area of core A_{cw} (mm ²) | Weight (g/set) | AL-value * | | Core loss |
| C1 (mm ⁻¹) | | | | | | | | (nH/N ²) | | (W)max. |
| 0.928 | 75.5 | 81.4 | 6150 | 77.0 | 73.1 | 148 | 33 | 1kHz 0.5mA | 100kHz 200mT | 100kHz 200mT 100°C |
| | | | | | | | | 2520±25% | 3660 min. | 2.03 |

* Coil : ø0.35 2UEW 100Ts

○ Calculated output power (forward converter mode): 267W (100kHz)

NI limit vs. AL-value (Typ.)

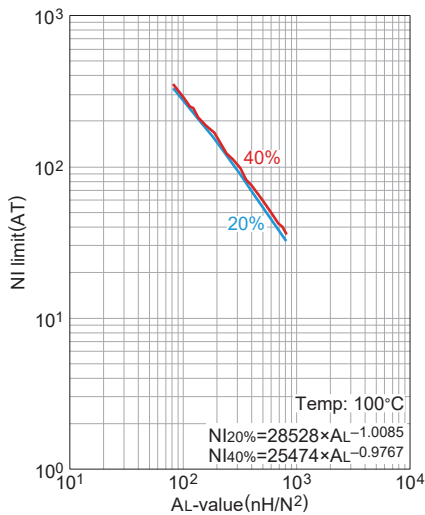

The 20% and 40% graph shows when a 20% and 40% drop from the initial AL-value has been made due to the DC superimposition.

AL-value vs. Air gap length (Typ.)

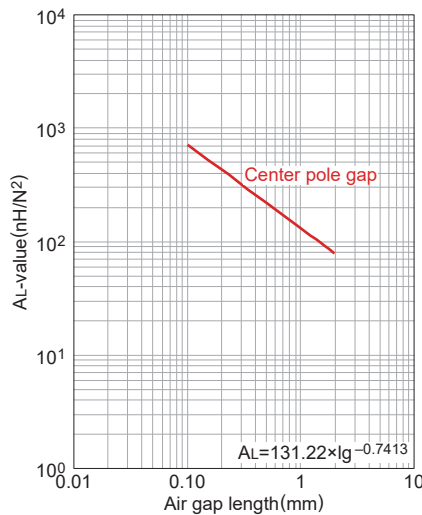

Measuring conditions
 • Coil : ø0.35 2UEW 100Ts
 • Frequency : 1kHz
 • Current level : 0.5mA
 • Ambient temperature : 25°C

Temperature rise vs. Total loss (Typ.)

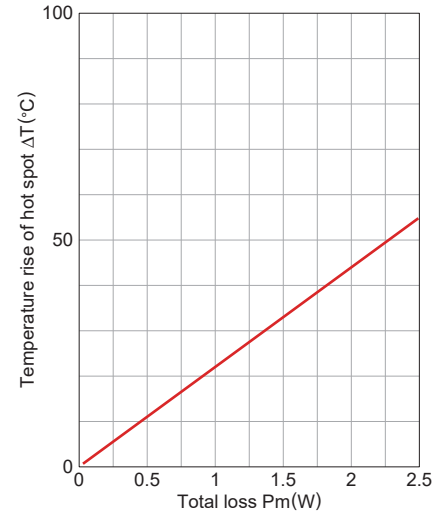

Measuring conditions
 • Room space: approx. 400x300x 300cm
 • Ambient temperature : 25°C
 • Humidity : 45%(%)RH.

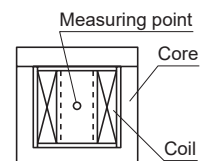

⚠ Please be sure to request delivery specifications that provide further details on the features and specifications of the products for proper and safe use. Please note that the contents may change without any prior notice due to reasons such as upgrading.

Mn-Zn E series Part No.: PC95EER28L-Z

SHAPES AND DIMENSIONS

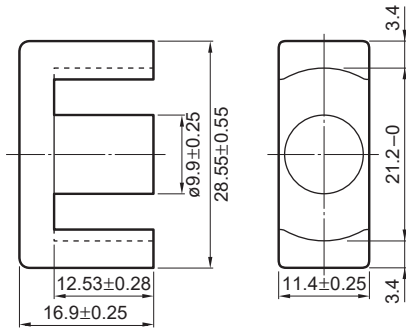

Dimensions in mm

Based on JIS FEER 28.5B.

| Effective parameter | | | | | | | | Electrical characteristics | | | | |
|------------------------|---|---|--|--|---|--|----------------|---------------------------------------|----------------------------|------|------|-------|
| Core factor | Effective magnetic path length l_e (mm) | Effective cross-sectional area A_e (mm ²) | Effective core volume V_e (mm ³) | Cross-sectional center pole area A_{cp} (mm ²) | Minimum cross-sectional center pole area $A_{cp \text{ min.}}$ (mm ²) | Cross-sectional winding area of core A_{cw} (mm ²) | Weight (g/set) | AL-value * | Core loss | | | |
| C1 (mm ⁻¹) | | | | | | | | (nH/N ²) 1kHz 0.5mA | (W)max. 100kHz 200mT | 25°C | 80°C | 120°C |
| 0.928 | 75.5 | 81.4 | 6150 | 77.0 | 73.1 | 148 | 33 | 3500±25% | 2.9 | 2.45 | 2.9 | |

* Coil : $\phi 0.35$ 2UEW 100Ts

○ Calculated output power (forward converter mode): 250W (100kHz)

NI limit vs. AL-value (Typ.)

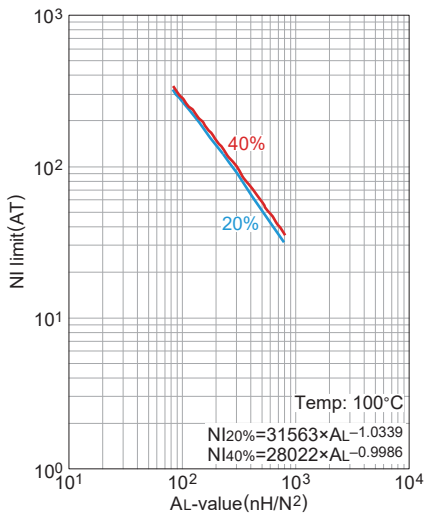

The 20% and 40% graph shows when a 20% and 40% drop from the initial AL-value has been made due to the DC superimposition.

AL-value vs. Air gap length (Typ.)

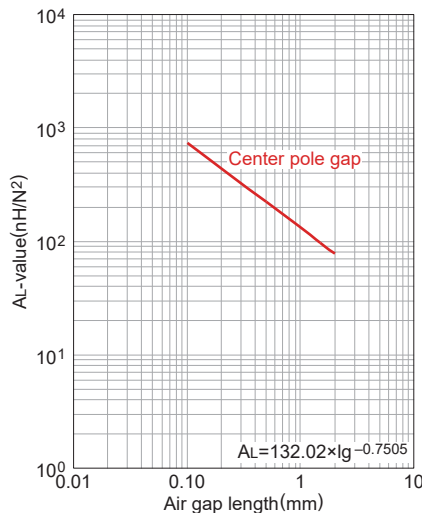

Measuring conditions
 • Coil : $\phi 0.35$ 2UEW 100Ts
 • Frequency : 1kHz
 • Current level : 0.5mA
 • Ambient temperature : 25°C

Temperature rise vs. Total loss (Typ.)

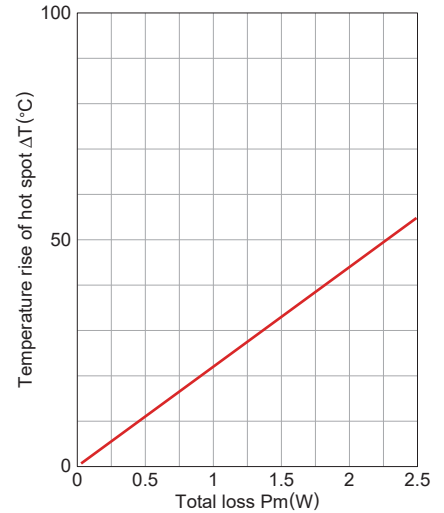

Measuring conditions
 • Room space: approx. 400x300x 300cm
 • Ambient temperature : 25°C
 • Humidity: 45%(%)RH.

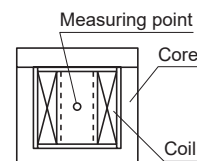

⚠ Please be sure to request delivery specifications that provide further details on the features and specifications of the products for proper and safe use. Please note that the contents may change without any prior notice due to reasons such as upgrading.

Mn-Zn E series Part No.: PC47EER35-Z

SHAPES AND DIMENSIONS

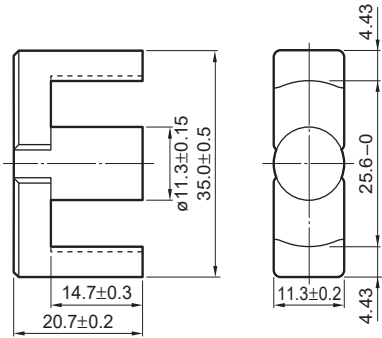

Dimensions in mm

Based on JIS FEER 35A.

| Effective parameter | | | | | | | | Electrical characteristics | | |
|------------------------|--|---|--|--|---|--|----------------|----------------------------|-----------------|--------------------------|
| Core factor | Effective magnetic path length ℓ_e (mm) | Effective cross-sectional area A_e (mm ²) | Effective core volume V_e (mm ³) | Cross-sectional center pole area A_{cp} (mm ²) | Minimum cross-sectional center pole area $A_{cp \text{ min.}}$ (mm ²) | Cross-sectional winding area of core A_{cw} (mm ²) | Weight (g/set) | AL-value * | | Core loss |
| C1 (mm ⁻¹) | | | | | | | | (nH/N ²) | | (W)max. |
| 0.849 | 90.8 | 107 | 9720 | 100 | 97.6 | 218 | 52 | 1kHz 0.5mA | 100kHz 200mT | 100kHz 200mT 100°C |
| | | | | | | | | 2770±25% | 4000 min. | 3.18 |

* Coil : ø0.35 2UEW 100Ts

○ Calculated output power (forward converter mode): 376W (100kHz)

NI limit vs. AL-value (Typ.)

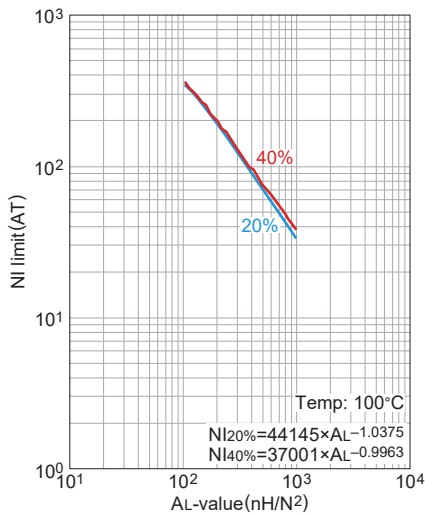

The 20% and 40% graph shows when a 20% and 40% drop from the initial AL-value has been made due to the DC superimposition.

AL-value vs. Air gap length (Typ.)

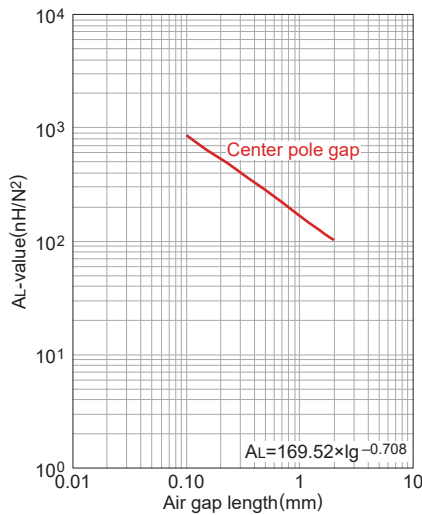

Measuring conditions
 • Coil : ø0.35 2UEW 100Ts
 • Frequency : 1kHz
 • Current level : 0.5mA
 • Ambient temperature : 25°C

Temperature rise vs. Total loss (Typ.)

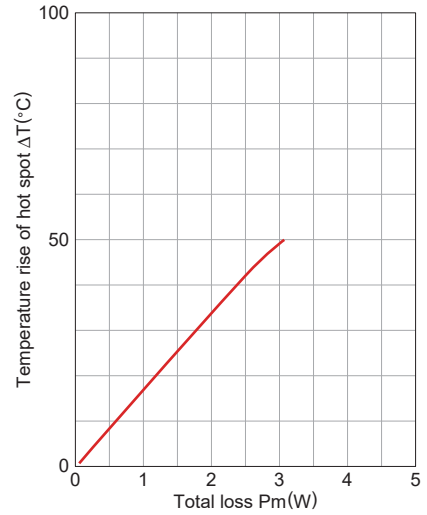

Measuring conditions
 • Room space: approx. 400x300x 300cm
 • Ambient temperature : 25°C
 • Humidity : 45(%)RH.

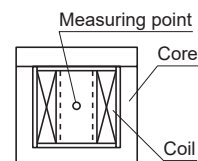

⚠ Please be sure to request delivery specifications that provide further details on the features and specifications of the products for proper and safe use. Please note that the contents may change without any prior notice due to reasons such as upgrading.

Mn-Zn E series Part No.: PC95EER35-Z

SHAPES AND DIMENSIONS

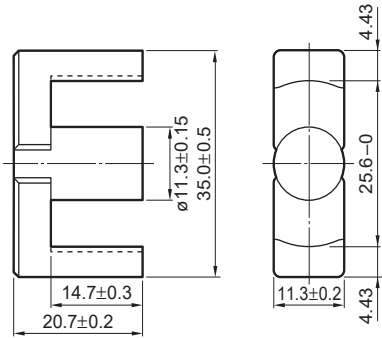

Dimensions in mm

Based on JIS FEER 35A.

| Effective parameter | | | | | | | | Electrical characteristics | | | | |
|------------------------|--|---|--|--|---|--|----------------|---------------------------------------|----------------------------|------|-------|--|
| Core factor | Effective magnetic path length ℓ_e (mm) | Effective cross-sectional area A_e (mm ²) | Effective core volume V_e (mm ³) | Cross-sectional center pole area A_{cp} (mm ²) | Minimum cross-sectional center pole area $A_{cp \text{ min.}}$ (mm ²) | Cross-sectional winding area of core A_{cw} (mm ²) | Weight (g/set) | AL-value * | Core loss | | | |
| C1 (mm ⁻¹) | | | | | | | | (nH/N ²) 1kHz 0.5mA | (W)max. 100kHz 200mT | | | |
| 0.849 | 90.8 | 107 | 9720 | 100 | 97.6 | 218 | 52 | 4000±25% | 25°C | 80°C | 120°C | |
| | | | | | | | | | 4.55 | 3.8 | 4.55 | |

* Coil : $\phi 0.35$ 2UEW 100Ts

○ Calculated output power (forward converter mode): 336W (100kHz)

NI limit vs. AL-value (Typ.)

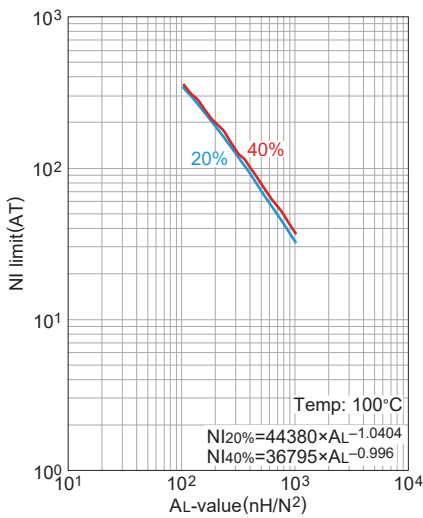

The 20% and 40% graph shows when a 20% and 40% drop from the initial AL-value has been made due to the DC superimposition.

AL-value vs. Air gap length (Typ.)

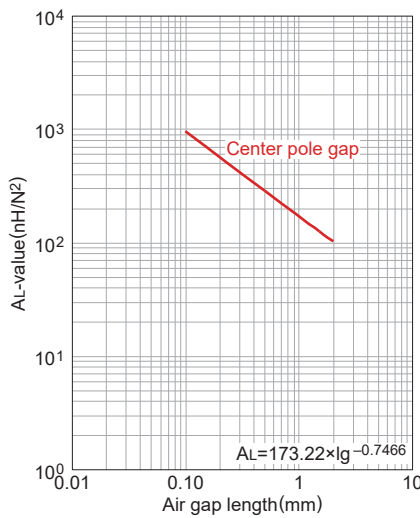

Measuring conditions
 • Coil : $\phi 0.35$ 2UEW 100Ts
 • Frequency : 1kHz
 • Current level : 0.5mA
 • Ambient temperature : 25°C

Temperature rise vs. Total loss (Typ.)

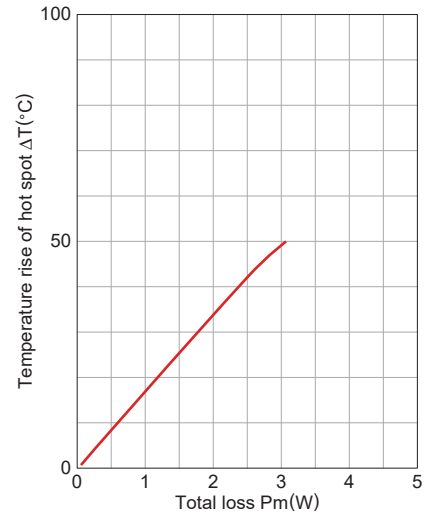

Measuring conditions
 • Room space: approx. 400x300x 300cm
 • Ambient temperature : 25°C
 • Humidity : 45(%RH).

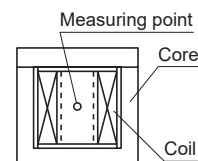

⚠ Please be sure to request delivery specifications that provide further details on the features and specifications of the products for proper and safe use. Please note that the contents may change without any prior notice due to reasons such as upgrading.

Mn-Zn E series Part No.: PC47EER40-Z

SHAPES AND DIMENSIONS

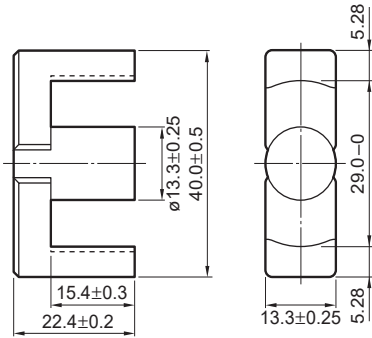

Dimensions in mm

| Effective parameter | | | | | | | | Electrical characteristics | | |
|------------------------------------|---|---|--|--|---|--|----------------|----------------------------|-----------------|--------------------------|
| Core factor | Effective magnetic path length l_e (mm) | Effective cross-sectional area A_e (mm ²) | Effective core volume V_e (mm ³) | Cross-sectional center pole area A_{cp} (mm ²) | Minimum cross-sectional center pole area $A_{cp \text{ min.}}$ (mm ²) | Cross-sectional winding area of core A_{cw} (mm ²) | Weight (g/set) | AL-value * | | Core loss |
| C ₁ (mm ⁻¹) | | | | | | | | (nH/N ²) | | (W)max. |
| 0.658 | 98.0 | 149 | 14600 | 139 | 134 | 249 | 78 | 1kHz 0.5mA | 100kHz 200mT | 100kHz 200mT 100°C |
| | | | | | | | | 3620±25% | 5160 min. | 4.77 |

* Coil : ø0.35 2UEW 100Ts

○ Calculated output power (forward converter mode): 484W (100kHz)

NI limit vs. AL-value (Typ.)

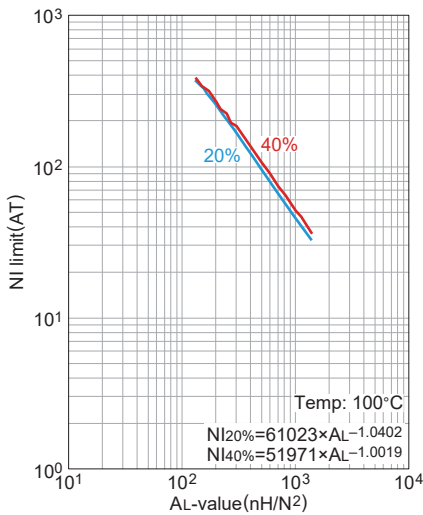

The 20% and 40% graph shows when a 20% and 40% drop from the initial AL-value has been made due to the DC superimposition.

AL-value vs. Air gap length (Typ.)

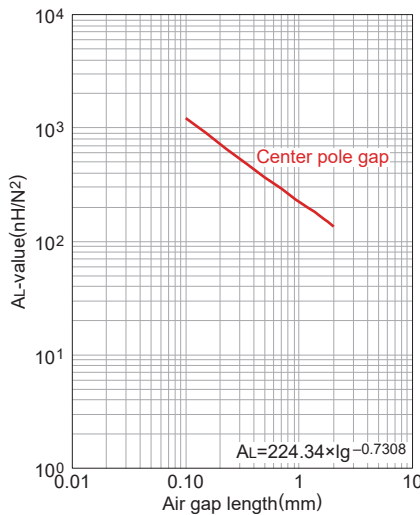

Measuring conditions

- Coil : ø0.35 2UEW 100Ts
- Frequency : 1kHz
- Current level : 0.5mA
- Ambient temperature : 25°C

Temperature rise vs. Total loss (Typ.)

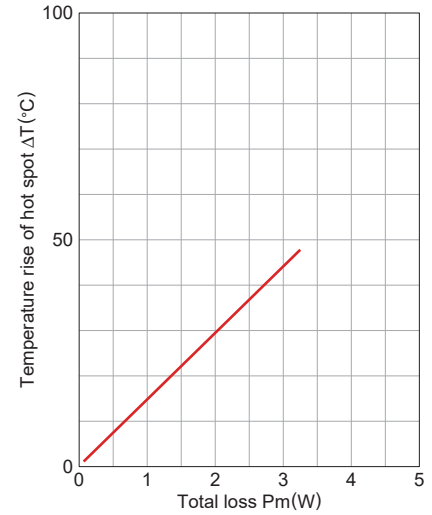

Measuring conditions

- Room space: approx. 400x300x 300cm
- Ambient temperature : 25°C
- Humidity : 45%(%)RH.

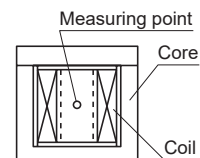

⚠ Please be sure to request delivery specifications that provide further details on the features and specifications of the products for proper and safe use. Please note that the contents may change without any prior notice due to reasons such as upgrading.

Mn-Zn E series Part No.: PC95EER40-Z

SHAPES AND DIMENSIONS

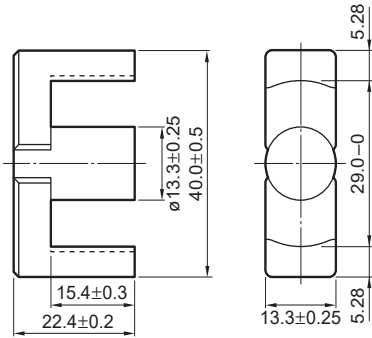

Dimensions in mm

| Effective parameter | | | | | | | | Electrical characteristics | | | |
|---------------------|---|---|--|--|---|--|----------------|---------------------------------|-------------------|------|-------|
| Core factor | Effective magnetic path length l_e (mm) | Effective cross-sectional area A_e (mm ²) | Effective core volume V_e (mm ³) | Cross-sectional center pole area A_{cp} (mm ²) | Minimum cross-sectional center pole area $A_{cp \text{ min.}}$ (mm ²) | Cross-sectional winding area of core A_{cw} (mm ²) | Weight (g/set) | AL-value * (nH/N ²) | Core loss (W)max. | | |
| C_1 | (mm ⁻¹) | | | | | | | 1kHz 0.5mA | 25°C | 80°C | 120°C |
| 0.658 | 98.0 | 149 | 14600 | 139 | 134 | 249 | 78 | 5200±25% | 6.8 | 5.7 | 6.8 |

* Coil : $\phi 0.35$ 2UEW 100Ts

○ Calculated output power (forward converter mode): 446W (100kHz)

NI limit vs. AL-value (Typ.)

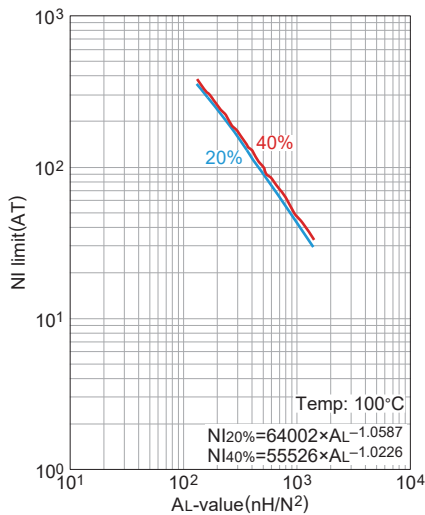

The 20% and 40% graph shows when a 20% and 40% drop from the initial AL-value has been made due to the DC superimposition.

AL-value vs. Air gap length (Typ.)

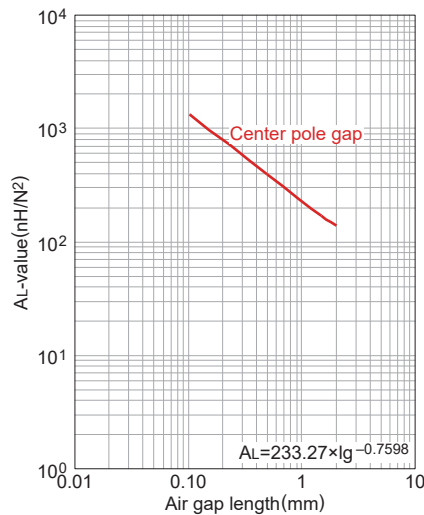

Measuring conditions
 • Coil : $\phi 0.35$ 2UEW 100Ts
 • Frequency : 1kHz
 • Current level : 0.5mA
 • Ambient temperature : 25°C

Temperature rise vs. Total loss (Typ.)

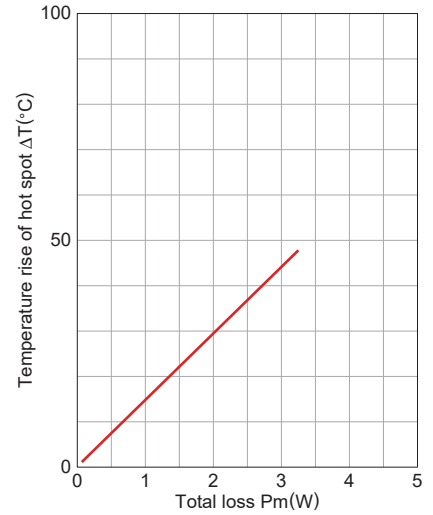

Measuring conditions
 • Room space: approx. 400x300x 300cm
 • Ambient temperature : 25°C
 • Humidity: 45%(%)RH.

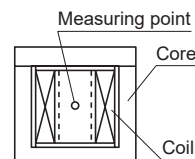

⚠ Please be sure to request delivery specifications that provide further details on the features and specifications of the products for proper and safe use. Please note that the contents may change without any prior notice due to reasons such as upgrading.

Mn-Zn E series Part No.: PC47EER42-Z

SHAPES AND DIMENSIONS

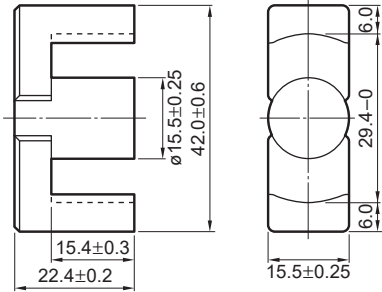

Dimensions in mm

Based on JIS FEER 42.

| Effective parameter | | | | | | | | Electrical characteristics | | |
|------------------------|--|---|--|--|---|--|----------------|----------------------------|-----------------|--------------------------|
| Core factor | Effective magnetic path length ℓ_e (mm) | Effective cross-sectional area A_e (mm ²) | Effective core volume V_e (mm ³) | Cross-sectional center pole area A_{cp} (mm ²) | Minimum cross-sectional center pole area $A_{cp \text{ min.}}$ (mm ²) | Cross-sectional winding area of core A_{cw} (mm ²) | Weight (g/set) | AL-value * | | Core loss |
| C1 (mm ⁻¹) | | | | | | | | (nH/N ²) | | (W)max. |
| | | | | | | | | 1kHz 0.5mA | 100kHz 200mT | 100kHz 200mT 100°C |
| 0.509 | 98.8 | 194 | 19200 | 187 | 183 | 223 | 102 | 4690±25% | 6670 min. | 6.47 |

* Coil : $\phi 0.35$ 2UEW 100Ts

○ Calculated output power (forward converter mode): 540W (100kHz)

NI limit vs. AL-value (Typ.)

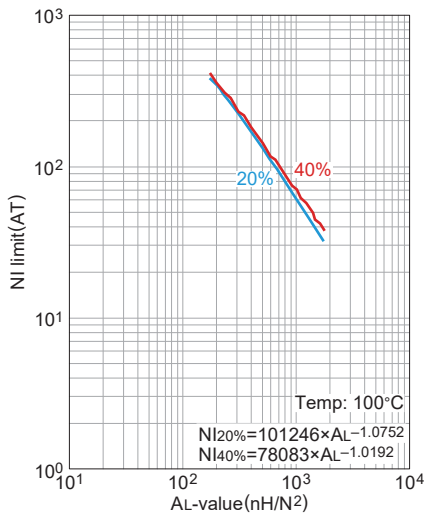

The 20% and 40% graph shows when a 20% and 40% drop from the initial AL-value has been made due to the DC superimposition.

AL-value vs. Air gap length (Typ.)

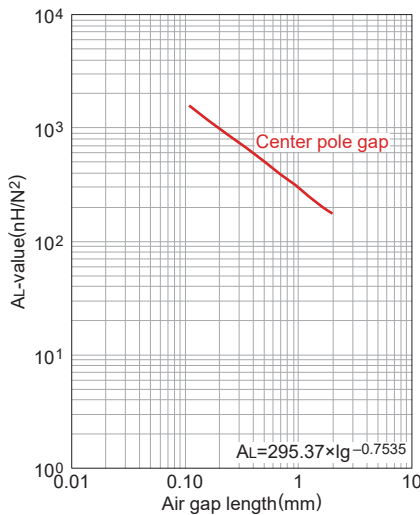

Measuring conditions
 • Coil : $\phi 0.35$ 2UEW 100Ts
 • Frequency : 1kHz
 • Current level : 0.5mA
 • Ambient temperature : 25°C

Temperature rise vs. Total loss (Typ.)

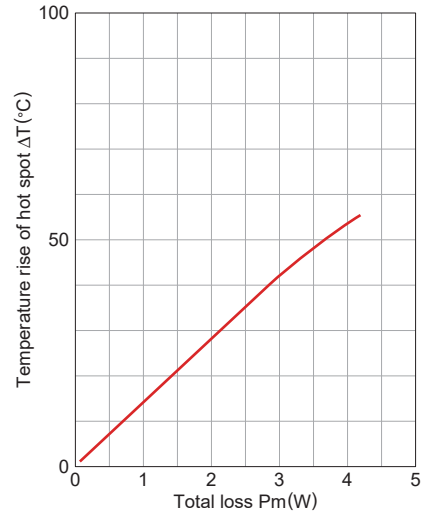

Measuring conditions
 • Room space: approx. 400x300x 300cm
 • Ambient temperature : 25°C
 • Humidity : 45%(%)RH.

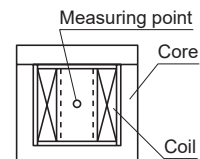

⚠ Please be sure to request delivery specifications that provide further details on the features and specifications of the products for proper and safe use. Please note that the contents may change without any prior notice due to reasons such as upgrading.

Mn-Zn E series Part No.: PC47EER42/42/20-Z

SHAPES AND DIMENSIONS

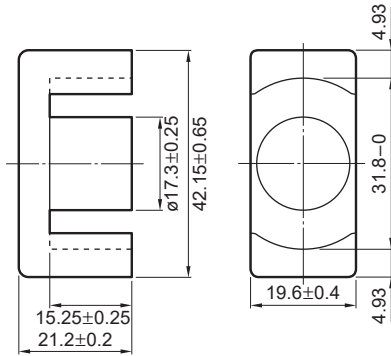

Dimensions in mm

| Effective parameter | | | | | | | | Electrical characteristics | | |
|-------------------------------|--------------------------------------|--------------------------------------|-----------------------------|---|--|---|---------|---|-----------------|-------------------------------------|
| Core factor | Effective magnetic path length l_e | Effective cross-sectional area A_e | Effective core volume V_e | Cross-sectional center pole area A_{cp} | Minimum cross-sectional center pole area $A_{cp \text{ min.}}$ | Cross-sectional winding area of core A_{cw} | Weight | AL-value * | | Core loss |
| C_1 (mm^{-1}) | (mm) | (mm^2) | (mm^3) | (mm^2) | (mm^2) | (mm^2) | (g/set) | (nH/N^2) 1kHz 0.5mA | 100kHz 200mT | (W)max. 100kHz 200mT 100°C |
| 0.411 | 98.6 | 240 | 23700 | 235 | 228 | 229 | 116 | 5340±25% | 8260 min. | 9.96 |

* Coil : $\phi 0.35$ 2UEW 100Ts

○ Calculated output power (forward converter mode): 647W (100kHz)

NI limit vs. AL-value (Typ.)

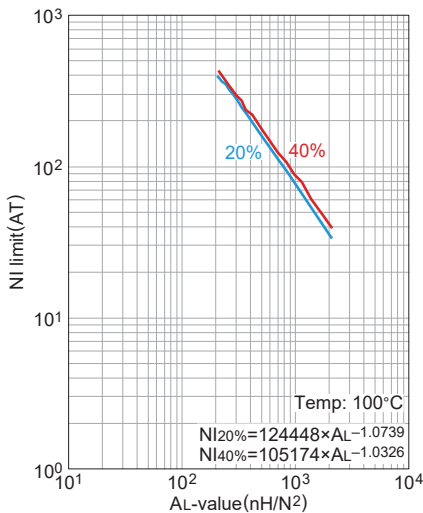

The 20% and 40% graph shows when a 20% and 40% drop from the initial AL-value has been made due to the DC superimposition.

AL-value vs. Air gap length (Typ.)

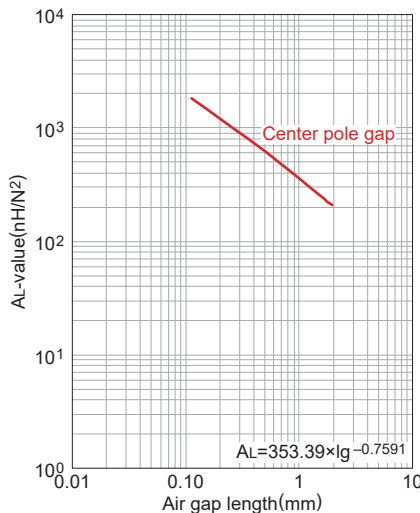

Measuring conditions

- Coil : $\phi 0.35$ 2UEW 100Ts
- Frequency : 1kHz
- Current level : 0.5mA
- Ambient temperature : 25°C

Temperature rise vs. Total loss (Typ.)

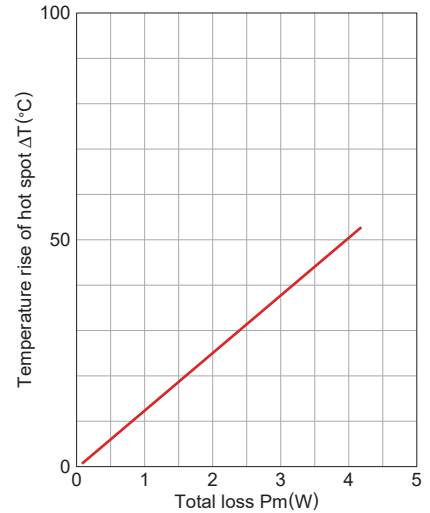

Measuring conditions

- Room space: approx. 400x300x 300cm
- Ambient temperature : 25°C
- Humidity : 45%(%)RH.

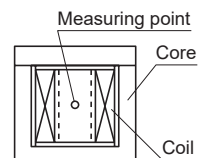

⚠ Please be sure to request delivery specifications that provide further details on the features and specifications of the products for proper and safe use. Please note that the contents may change without any prior notice due to reasons such as upgrading.

Mn-Zn ETD Cores



SHAPES AND DIMENSIONS

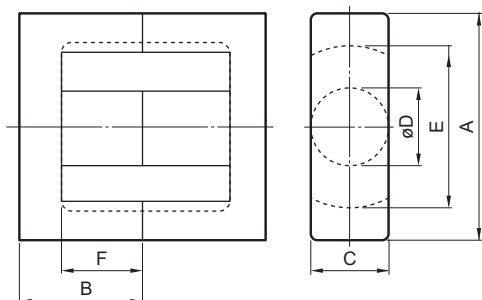

| | | | |
|----------|----------------|---|----------------------------------|
| PC47 | ETD19 | - | Z |
| Material | Size of E core | | AL-value (Z: without air gap) |

| Part No. | JIS | Dimensions (mm) | | | | | |
|-------------|------------------|-----------------|------------|------------|-----------------|----------|----------|
| | | A | B | C | $\varnothing D$ | E | F |
| PC47ETD19-Z | | 19.6±0.5 | 13.65±0.15 | 7.4±0.2 | 7.4±0.2 | 14.9±0.5 | 9.4±0.2 |
| PC47ETD24-Z | | 24.4±0.6 | 14.45±0.15 | 8.5±0.4 | 8.5±0.2 | 18.6±0.6 | 10.1±0.2 |
| PC47ETD29-Z | | 29.8±0.8 | 15.80±0.15 | 9.5±0.3 | 9.5±0.3 | 22.7±0.7 | 11.0±0.3 |
| PC47ETD34-Z | JIS FEER 34.2 | 34.2±0.8 | 17.3±0.2 | 10.88±0.38 | 10.8±0.3 | 26.3±0.7 | 12.1±0.3 |
| PC47ETD39-Z | JIS FEER 39.1 | 39.1±0.9 | 19.8±0.2 | 12.58±0.38 | 12.5±0.3 | 30.1±0.8 | 14.6±0.4 |
| PC47ETD44-Z | JIS FEER 44 | 44.0±1.0 | 22.3±0.2 | 14.9±0.5 | 14.8±0.4 | 33.3±0.8 | 16.5±0.4 |
| PC47ETD49-Z | JIS FEER 48.7 | 48.7±1.1 | 24.7±0.2 | 16.4±0.5 | 16.3±0.4 | 37.0±0.9 | 18.1±0.4 |

| Part No. | Effective parameter | | | | | Electrical characteristics | | |
|-------------|--------------------------------------|--|--|---|---------------|--|-------------------|---|
| | Core factor $C_1(\text{mm}^{-1})$ | Effective cross-sectional area $A_e(\text{mm}^2)$ | Effective magnetic path length $l_e(\text{mm})$ | Effective core volume $V_e(\text{mm}^3)$ | Weight (g) | AL-value (nH/N ²) 1kHz 0.5mA 100Ts Without air gap With air gap | | Core loss (W) max. 100kHz 200mT 100°C |
| PC47ETD19-Z | 1.32 | 41.3 | 54.6 | 2260 | 14 | 1720±25% | 80±5% 160±7% | 1.01 |
| PC47ETD24-Z | 1.100 | 56.3 | 61.9 | 3480 | 20 | 2125±25% | 100±5% 200±7% | 1.51 |
| PC47ETD29-Z | 0.959 | 73.6 | 70.6 | 5200 | 28 | 2500±25% | 200±5% 400±10% | 1.75 |
| PC47ETD34-Z | 0.810 | 97.1 | 78.6 | 7630 | 40 | 2780±25% | 200±5% 400±7% | 2.52 |
| PC47ETD39-Z | 0.737 | 125 | 92.1 | 11500 | 60 | 3150±25% | 200±5% 400±7% | 3.96 |
| PC47ETD44-Z | 0.589 | 175 | 103 | 18000 | 94 | 4000±25% | 250±5% 400±7% | 6.20 |
| PC47ETD49-Z | 0.535 | 213 | 114 | 24300 | 124 | 4440±25% | 250±5% 400±7% | 10.25 |

⚠ Please be sure to request delivery specifications that provide further details on the features and specifications of the products for proper and safe use. Please note that the contents may change without any prior notice due to reasons such as upgrading.

Mn-Zn E series Part No.: PC47ETD19-Z

SHAPES AND DIMENSIONS

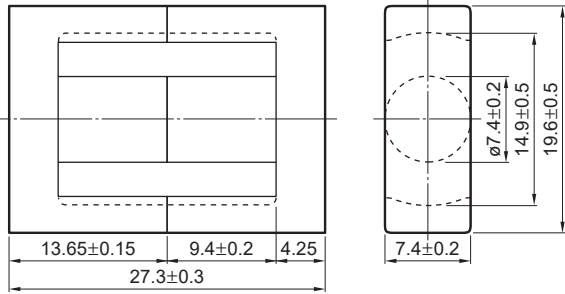

Dimensions in mm

| Effective parameter | | | | | | | | Electrical characteristics | | |
|------------------------------------|---|---|--|--|---|--|----------------|----------------------------|-----------------|--------------------------|
| Core factor | Effective magnetic path length l_e (mm) | Effective cross-sectional area A_e (mm ²) | Effective core volume V_e (mm ³) | Cross-sectional center pole area A_{cp} (mm ²) | Minimum cross-sectional center pole area $A_{cp \text{ min.}}$ (mm ²) | Cross-sectional winding area of core A_{cw} (mm ²) | Weight (g/set) | AL-value * | | Core loss |
| C ₁ (mm ⁻¹) | | | | | | | | (nH/N ²) | | (W)max. |
| 1.32 | 54.6 | 41.3 | 2260 | 43 | 40.7 | 70.5 | 13.3 | 1kHz 0.5mA | 100kHz 200mT | 100kHz 200mT 100°C |
| | | | | | | | | 1720±25% | 2380 min. | 1.01 |

* Coil : ø0.35 2UEW 100Ts

○ Calculated output power (forward converter mode): 114W (100kHz)

NI limit vs. AL-value (Typ.)

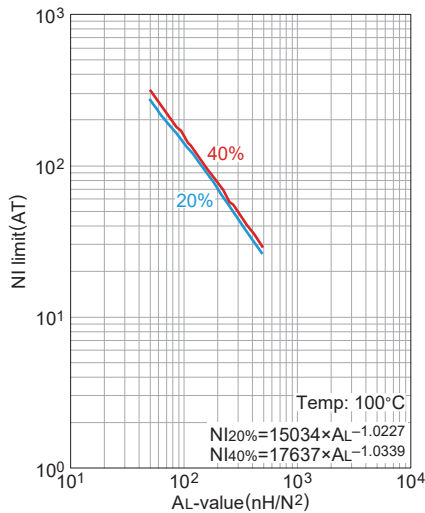

The 20% and 40% graph shows when a 20% and 40% drop from the initial AL-value has been made due to the DC superimposition.

AL-value vs. Air gap length (Typ.)

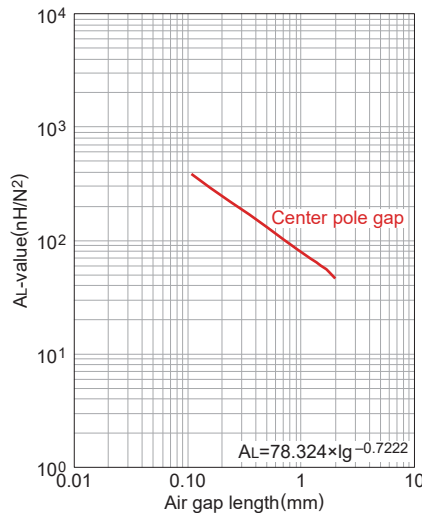

Measuring conditions

- Coil : ø0.35 2UEW 100Ts
- Frequency : 1kHz
- Current level : 0.5mA
- Ambient temperature : 25°C

Temperature rise vs. Total loss (Typ.)

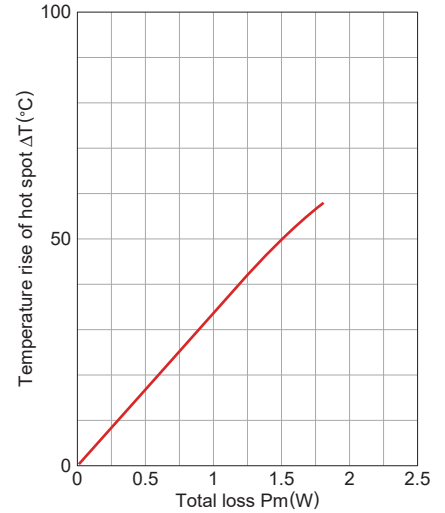

Measuring conditions

- Room space: approx. 400x300x 300cm
- Ambient temperature : 25°C
- Humidity: 45%(%)RH.

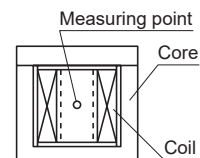

⚠ Please be sure to request delivery specifications that provide further details on the features and specifications of the products for proper and safe use. Please note that the contents may change without any prior notice due to reasons such as upgrading.

Mn-Zn E series Part No.: PC47ETD24-Z

SHAPES AND DIMENSIONS

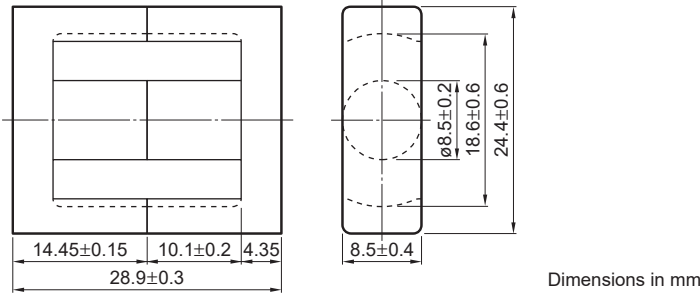

| Effective parameter | | | | | | | Electrical characteristics | | | |
|---------------------------------------|---|---|--|--|---|--|----------------------------|----------------------|-----------------|--------------------------|
| Core factor | Effective magnetic path length l_e (mm) | Effective cross-sectional area A_e (mm ²) | Effective core volume V_e (mm ³) | Cross-sectional center pole area A_{cp} (mm ²) | Minimum cross-sectional center pole area $A_{cp \text{ min.}}$ (mm ²) | Cross-sectional winding area of core A_{cw} (mm ²) | Weight (g/set) | AL-value * | | Core loss |
| C ₁ (mm ⁻¹) | | | | | | | | (nH/N ²) | | (W)max. |
| 1.10 | 61.9 | 56.3 | 3480 | 56.7 | 54.1 | 102 | 19.5 | 1kHz 0.5mA | 100kHz 200mT | 100kHz 200mT 100°C |
| | | | | | | | | 2125±25% | 2860 min. | 1.51 |

* Coil : ø0.35 2UEW 100Ts

○ Calculated output power (forward converter mode): 131W (100kHz)

NI limit vs. AL-value (Typ.)

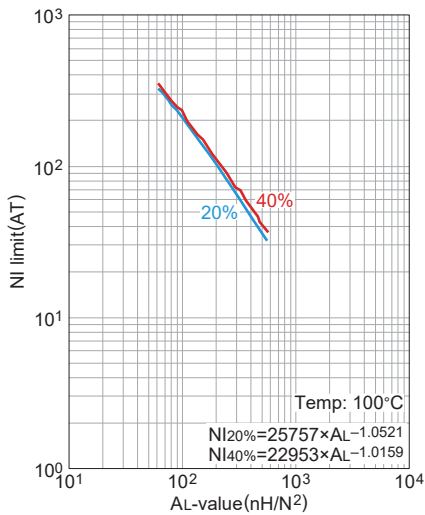

The 20% and 40% graph shows when a 20% and 40% drop from the initial AL-value has been made due to the DC superimposition.

AL-value vs. Air gap length (Typ.)

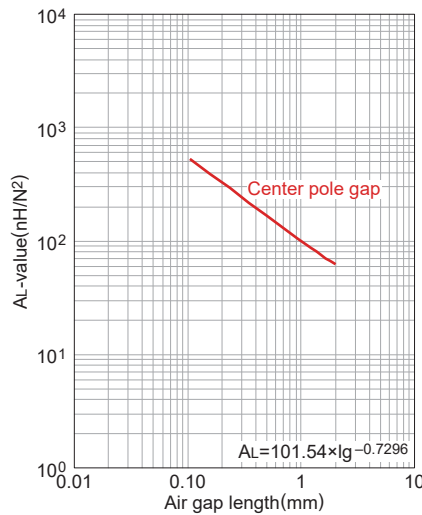

Measuring conditions

- Coil : ø0.35 2UEW 100Ts
- Frequency : 1kHz
- Current level : 0.5mA
- Ambient temperature : 25°C

Temperature rise vs. Total loss (Typ.)

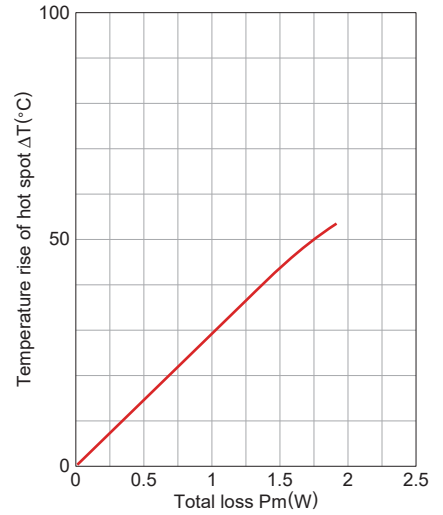

Measuring conditions

- Room space: approx. 400x300x 300cm
- Ambient temperature : 25°C
- Humidity : 45(%)RH.

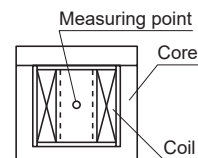

⚠ Please be sure to request delivery specifications that provide further details on the features and specifications of the products for proper and safe use. Please note that the contents may change without any prior notice due to reasons such as upgrading.

Mn-Zn E series Part No.: PC47ETD29-Z

SHAPES AND DIMENSIONS

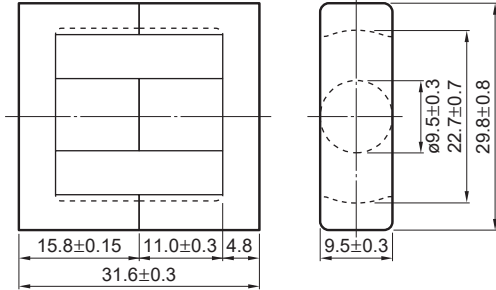

Dimensions in mm

| Effective parameter | | | | | | | Electrical characteristics | | | | |
|---------------------------|---|---|--|--|---|--|----------------------------|----------------------|-----------------|--------------------------|--|
| Core factor | Effective magnetic path length l_e (mm) | Effective cross-sectional area A_e (mm ²) | Effective core volume V_e (mm ³) | Cross-sectional center pole area A_{cp} (mm ²) | Minimum cross-sectional center pole area $A_{cp \text{ min.}}$ (mm ²) | Cross-sectional winding area of core A_{cw} (mm ²) | Weight (g/set) | AL-value * | | Core loss | |
| C_1 (mm ⁻¹) | | | | | | | | (nH/N ²) | | (W)max. | |
| 0.959 | 70.6 | 73.6 | 5200 | 70.9 | 66.5 | 145.2 | 28 | 1kHz 0.5mA | 100kHz 200mT | 100kHz 200mT 100°C | |
| | | | | | | | | 2500±25% | 3540 min. | 1.75 | |

* Coil : ø0.35 2UEW 100Ts

○ Calculated output power (forward converter mode): 242W (100kHz)

NI limit vs. AL-value (Typ.)

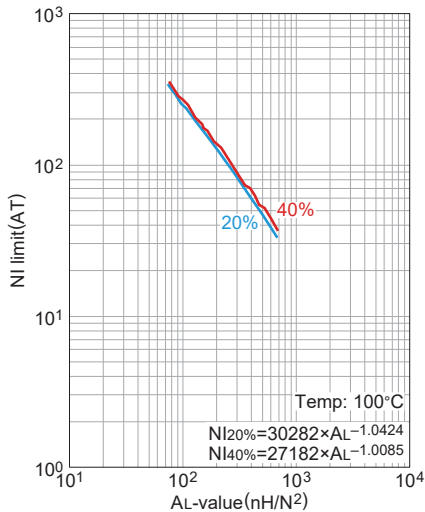

The 20% and 40% graph shows when a 20% and 40% drop from the initial AL-value has been made due to the DC superimposition.

AL-value vs. Air gap length (Typ.)

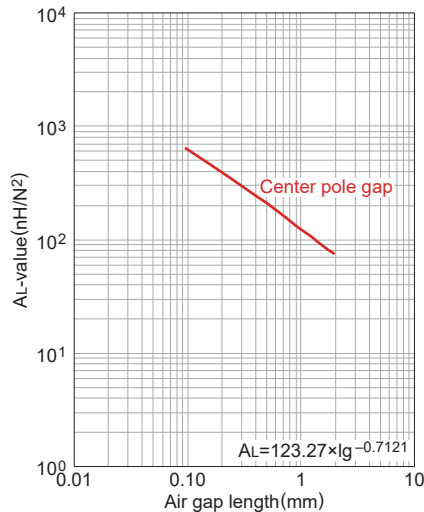

Measuring conditions

- Coil : ø0.35 2UEW 100Ts
- Frequency : 1kHz
- Current level : 0.5mA
- Ambient temperature : 25°C

Temperature rise vs. Total loss (Typ.)

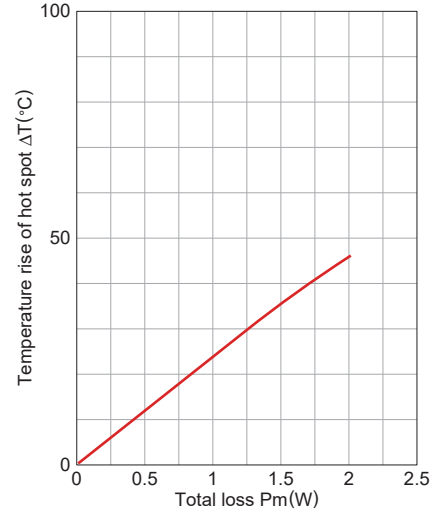

Measuring conditions

- Room space: approx. 400x300x 300cm
- Ambient temperature : 25°C
- Humidity: 45(%)RH.

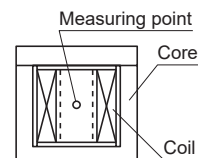

⚠ Please be sure to request delivery specifications that provide further details on the features and specifications of the products for proper and safe use. Please note that the contents may change without any prior notice due to reasons such as upgrading.

Mn-Zn E series Part No.: PC47ETD34-Z

SHAPES AND DIMENSIONS

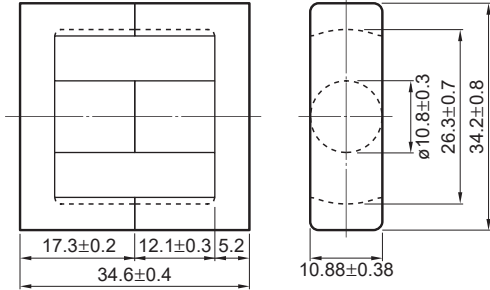

Dimensions in mm

| Effective parameter | | | | | | | | Electrical characteristics | | |
|---------------------------|---|---|--|--|---|--|----------------|----------------------------|-----------------|--------------------------|
| Core factor | Effective magnetic path length l_e (mm) | Effective cross-sectional area A_e (mm ²) | Effective core volume V_e (mm ³) | Cross-sectional center pole area A_{cp} (mm ²) | Minimum cross-sectional center pole area $A_{cp \text{ min.}}$ (mm ²) | Cross-sectional winding area of core A_{cw} (mm ²) | Weight (g/set) | AL-value * | | Core loss |
| C_1 (mm ⁻¹) | | | | | | | | (nH/N ²) | | (W)max. |
| 0.810 | 78.6 | 97.1 | 7630 | 91.6 | 86.6 | 188 | 40 | 1kHz 0.5mA | 100kHz 200mT | 100kHz 200mT 100°C |
| | | | | | | | | 2780±25% | 4190 min. | 2.52 |

* Coil : $\phi 0.35$ 2UEW 100Ts

○ Calculated output power (forward converter mode): 321W (100kHz)

NI limit vs. AL-value (Typ.)

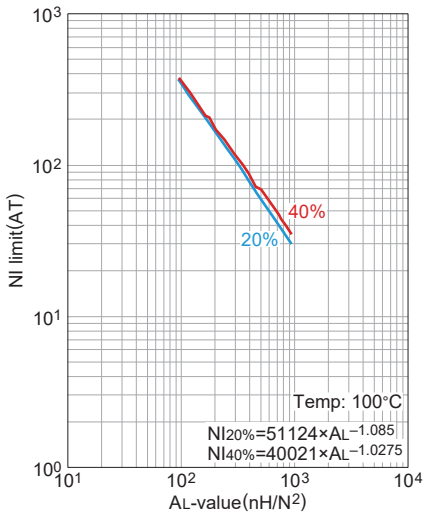

The 20% and 40% graph shows when a 20% and 40% drop from the initial AL-value has been made due to the DC superimposition.

AL-value vs. Air gap length (Typ.)

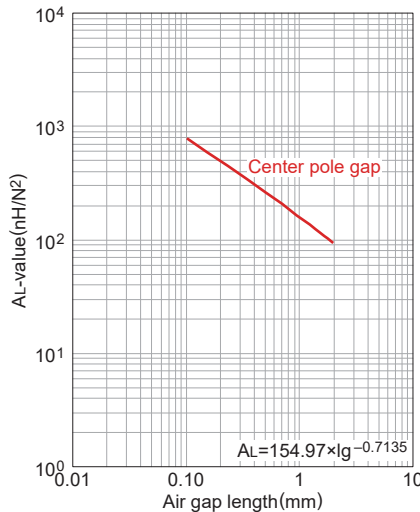

Measuring conditions

- Coil : $\phi 0.35$ 2UEW 100Ts
- Frequency : 1kHz
- Current level : 0.5mA
- Ambient temperature : 25°C

Temperature rise vs. Total loss (Typ.)

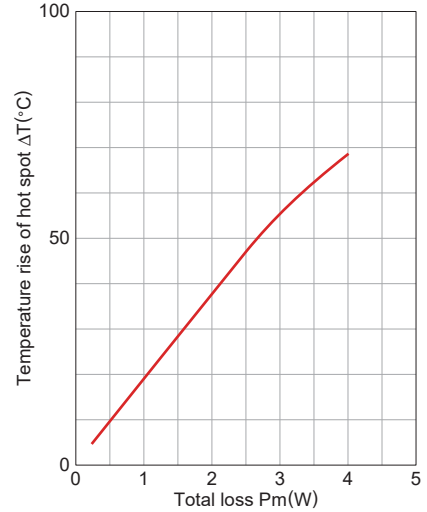

Measuring conditions

- Room space: approx. 400x300x 300cm
- Ambient temperature : 25°C
- Humidity : 45%(%)RH.

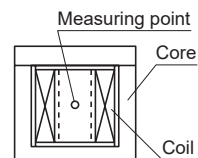

⚠ Please be sure to request delivery specifications that provide further details on the features and specifications of the products for proper and safe use. Please note that the contents may change without any prior notice due to reasons such as upgrading.

Mn-Zn E series Part No.: PC47ETD39-Z

SHAPES AND DIMENSIONS

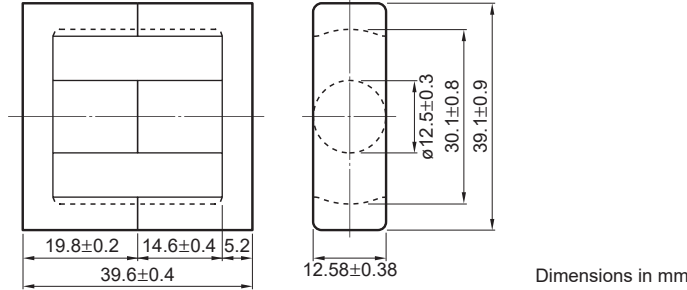

Based on JIS FEI 12.5.

| Effective parameter | | | | | | | | Electrical characteristics | | |
|------------------------|--|---|--|--|---|--|----------------|----------------------------|-----------------|--------------------------|
| Core factor | Effective magnetic path length ℓ_e (mm) | Effective cross-sectional area A_e (mm ²) | Effective core volume V_e (mm ³) | Cross-sectional center pole area A_{cp} (mm ²) | Minimum cross-sectional center pole area $A_{cp \text{ min.}}$ (mm ²) | Cross-sectional winding area of core A_{cw} (mm ²) | Weight (g/set) | AL-value * | | Core loss |
| C1 (mm ⁻¹) | | | | | | | | (nH/N ²) | | (W)max. |
| 0.737 | 92.1 | 125 | 11500 | 123 | 117 | 257 | 60 | 1kHz 0.5mA | 100kHz 200mT | 100kHz 200mT 100°C |
| | | | | | | | | 3150±25% | 4600 min. | 3.96 |

* Coil : $\phi 0.35$ 2UEW 100Ts

○ Calculated output power (forward converter mode): 450W (100kHz)

NI limit vs. AL-value (Typ.)

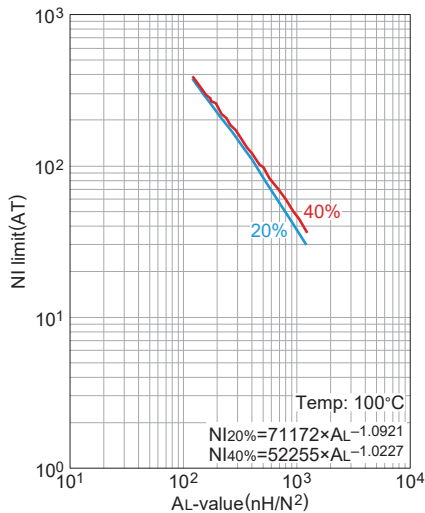

The 20% and 40% graph shows when a 20% and 40% drop from the initial AL-value has been made due to the DC superimposition.

AL-value vs. Air gap length (Typ.)

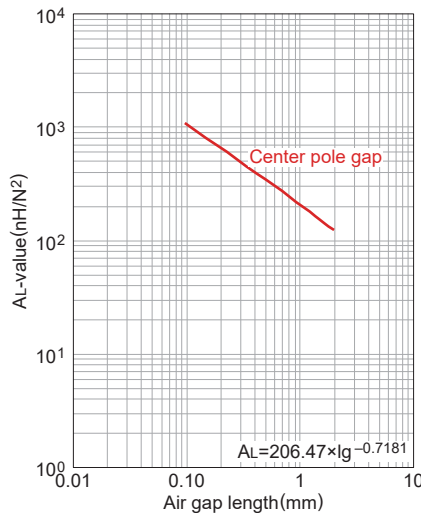

Measuring conditions
 • Coil : $\phi 0.35$ 2UEW 100Ts
 • Frequency : 1kHz
 • Current level : 0.5mA
 • Ambient temperature : 25°C

Temperature rise vs. Total loss (Typ.)

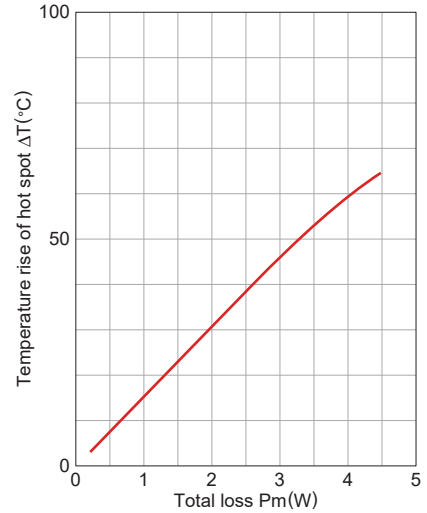

Measuring conditions
 • Room space: approx. 400x300x 300cm
 • Ambient temperature : 25°C
 • Humidity : 45%(%)RH.

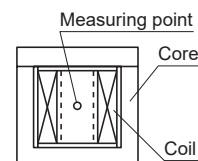

⚠ Please be sure to request delivery specifications that provide further details on the features and specifications of the products for proper and safe use. Please note that the contents may change without any prior notice due to reasons such as upgrading.

Mn-Zn E series Part No.: PC47ETD44-Z

SHAPES AND DIMENSIONS

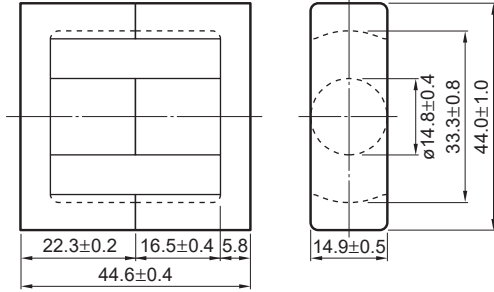

Dimensions in mm

| Effective parameter | | | | | | | | Electrical characteristics | | |
|---------------------------|---|---|--|--|---|--|----------------|----------------------------|-----------------|--------------------------|
| Core factor | Effective magnetic path length l_e (mm) | Effective cross-sectional area A_e (mm ²) | Effective core volume V_e (mm ³) | Cross-sectional center pole area A_{cp} (mm ²) | Minimum cross-sectional center pole area $A_{cp \text{ min.}}$ (mm ²) | Cross-sectional winding area of core A_{cw} (mm ²) | Weight (g/set) | AL-value * | | Core loss |
| C_1 (mm ⁻¹) | | | | | | | | (nH/N ²) | | (W)max. |
| 0.589 | 103 | 175 | 18000 | 172 | 163 | 305 | 94 | 1kHz 0.5mA | 100kHz 200mT | 100kHz 200mT 100°C |
| | | | | | | | | 4000±25% | 5760 min. | 6.2 |

* Coil : ø0.35 2UEW 100Ts

○ Calculated output power (forward converter mode): 581W (100kHz)

NI limit vs. AL-value (Typ.)

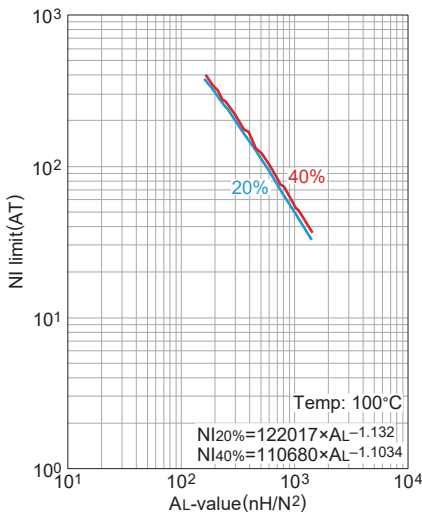

The 20% and 40% graph shows when a 20% and 40% drop from the initial AL-value has been made due to the DC superimposition.

AL-value vs. Air gap length (Typ.)

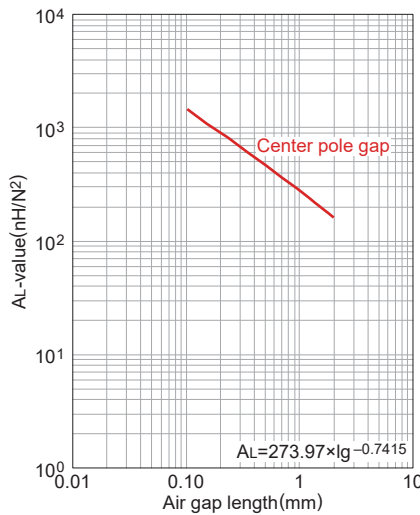

Measuring conditions

- Coil : ø0.35 2UEW 100Ts
- Frequency : 1kHz
- Current level : 0.5mA
- Ambient temperature : 25°C

Temperature rise vs. Total loss (Typ.)

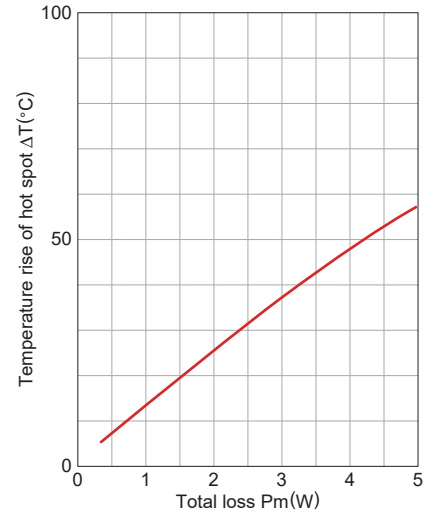

Measuring conditions

- Room space: approx. 400x300x 300cm
- Ambient temperature : 25°C
- Humidity: 45%(%)RH.

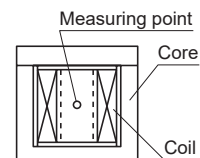

⚠ Please be sure to request delivery specifications that provide further details on the features and specifications of the products for proper and safe use. Please note that the contents may change without any prior notice due to reasons such as upgrading.

Mn-Zn E series Part No.: PC47ETD49-Z

SHAPES AND DIMENSIONS

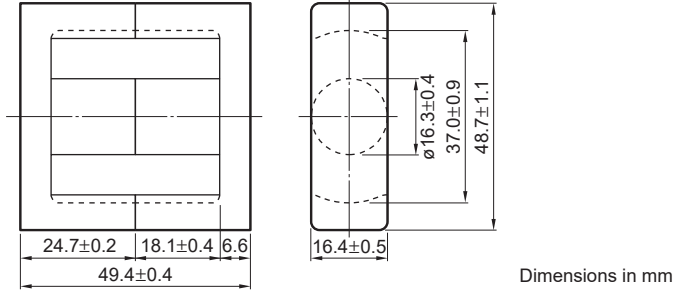

Based on JIS FEI 12.5.

| Effective parameter | | | | | | | | Electrical characteristics | | |
|------------------------|--|---|--|--|---|--|----------------|----------------------------|-----------|-----------|
| Core factor | Effective magnetic path length ℓ_e (mm) | Effective cross-sectional area A_e (mm ²) | Effective core volume V_e (mm ³) | Cross-sectional center pole area A_{cp} (mm ²) | Minimum cross-sectional center pole area $A_{cp \text{ min.}}$ (mm ²) | Cross-sectional winding area of core A_{cw} (mm ²) | Weight (g/set) | AL-value * | | Core loss |
| C1 (mm ⁻¹) | | | | | | | | (nH/N ²) | | (W)max. |
| | | | | | | | | 1kHz | 100kHz | 100kHz |
| | | | | | | | | 0.5mA | 200mT | 200mT |
| | | | | | | | | | | 100°C |
| 0.535 | 114 | 213 | 24300 | 209 | 199 | 375 | 124 | 4440±25% | 6340 min. | 10.25 |

* Coil : $\phi 0.35$ 2UEW 100Ts

○ Calculated output power (forward converter mode): 692W (100kHz)

NI limit vs. AL-value (Typ.)

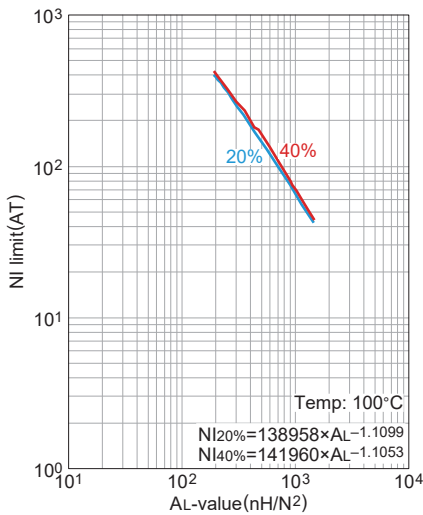

The 20% and 40% graph shows when a 20% and 40% drop from the initial AL-value has been made due to the DC superimposition.

AL-value vs. Air gap length (Typ.)

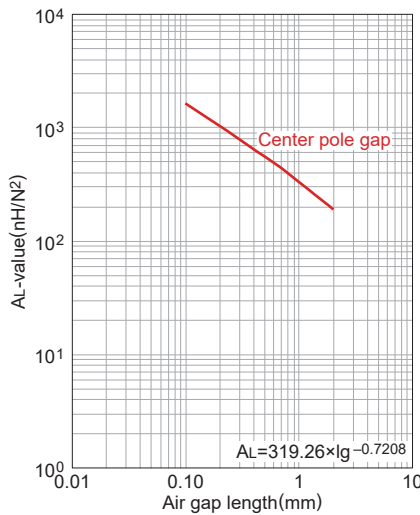

Measuring conditions

- Coil : $\phi 0.35$ 2UEW 100Ts
- Frequency : 1kHz
- Current level : 0.5mA
- Ambient temperature : 25°C

Temperature rise vs. Total loss (Typ.)

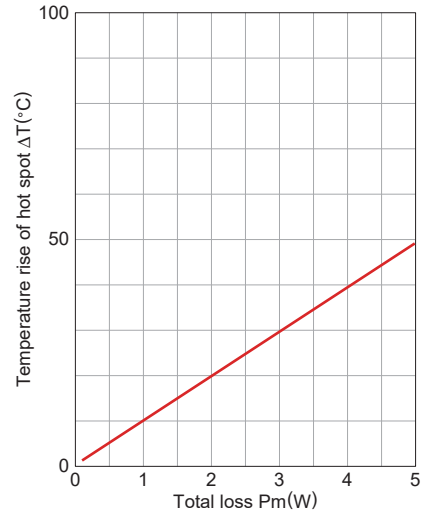

Measuring conditions

- Room space: approx. 400x300x 300cm
- Ambient temperature : 25°C
- Humidity : 45(%)RH.

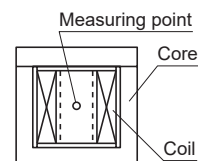

⚠ Please be sure to request delivery specifications that provide further details on the features and specifications of the products for proper and safe use. Please note that the contents may change without any prior notice due to reasons such as upgrading.

Mn-Zn

Ferrite Cores for Switching Power Supplies

EP series

**REMINDERS FOR USING THESE PRODUCTS**

Please be sure to read this manual thoroughly before using the products.

The products listed on this catalog are intended for use in general electronic equipment (AV equipment, telecommunications equipment, home appliances, amusement equipment, computer equipment, personal equipment, office equipment, measurement equipment, industrial robots) under a normal operation and use condition.

The products are not designed or warranted to meet the requirements of the applications listed below, whose performance and/or quality require a more stringent level of safety or reliability, or whose failure, malfunction or trouble could cause serious damage to society, person or property.

When using the products for specific purposes, please first make confirmations in areas such as safety, reliability, and quality.

Please understand that we are not in a position to be held responsible for any damage or the like caused by any use exceeding the range or conditions of this specification sheet or by any use in the specific applications.

- | | |
|---|--|
| (1) Aerospace/Aviation equipment | (8) Public information-processing equipment |
| (2) Transportation equipment (electric trains, ships, etc.) | (9) Military equipment |
| (3) Medical equipment | (10) Electric heating apparatus, burning equipment |
| (4) Power-generation control equipment | (11) Disaster prevention/crime prevention equipment |
| (5) Atomic energy-related equipment | (12) Safety equipment |
| (6) Seabed equipment | (13) Other applications that are not considered general-purpose applications |
| (7) Transportation control equipment | |

When using this product in general-purpose standard applications, you are kindly requested to take into consideration securing protection circuit/equipment or providing backup circuits, etc to ensure higher safety.

Ferrite Cores for Switching Power Supplies

Product compatible with RoHS directive
Halogen-free

Overview of the EP Series

FEATURES

- TDK's original shapes.
- The EP Core, apart from the area for attaching terminals, is entirely covers the coils, a construction which reduces leakage flux.

APPLICATION

Transformers and coils for Switched-mode power supplies (High Mounting Density, Low Profile)

PART NUMBER CONSTRUCTION

| | | | | | |
|-----------------|-------------------------------------|--|---|-------------------------------------|----------------------------|
| PC47 | EP7 | Z | - | 1 | 2 |
| Material | Size of EP core | AL-value (Z: without air gap) | | Type | Number of lead slot |
| PC47 | EP7 EP10 EP13 EP17 EP20 | | | 1 Without air gap 2 With air gap | |

RANGE OF USE AND STORAGE TEMPERATURE

| Temperature range | |
|-------------------------------|-----------------------------|
| Operating temperature (°C) | Storage temperature (°C) |
| -30 to +105 | -30 to +85 |

- RoHS Directive Compliant Product: See the following for more details related to RoHS Directive compliant products. <http://www.tdk.co.jp/rohs/>
- Halogen-free: Indicates that Cl content is less than 900ppm, Br content is less than 900ppm, and that the total Cl and Br content is less than 1500ppm.

• All specifications are subject to change without notice.

Mn-Zn EP Core



SHAPES AND DIMENSIONS

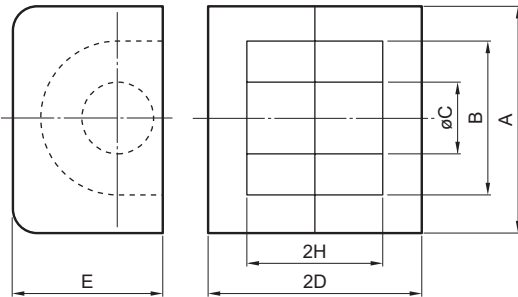

| | | | | | |
|-----------------|------------------------|--|---|-------------------|----------------------------|
| PC47 | EP7 | Z | - | 1 | 2 |
| Material | Size of EP core | AL-value (Z: without air gap) | | Type | Number of lead slot |
| | | | | 1 Without air gap | |
| | | | | 2 With air gap | |

| Part No. | Dimensions (mm) | | | | | |
|------------|-----------------|----------|-----------|------------|------------|----------|
| | A | B | øC | 2D | E | 2H |
| PC47EP7-Z | 9.2±0.2 | 7.4±0.2 | 3.3±0.1 | 7.4±0.1 | 6.35±0.15 | 5.2±0.2 |
| PC47EP10-Z | 11.5±0.3 | 9.4±0.2 | 3.3±0.15 | 10.2±0.2 | 7.65±0.2 | 7.4±0.2 |
| PC47EP13-Z | 12.5±0.3 | 10.0±0.3 | 4.35±0.15 | 12.85±0.15 | 8.8±0.2 | 9.2±0.2 |
| PC47EP17-Z | 18.0±0.4 | 12.0±0.4 | 5.68±0.18 | 16.8±0.2 | 11.0±0.25 | 11.3±0.3 |
| PC47EP20-Z | 24.0±0.5 | 16.5±0.4 | 8.75±0.25 | 21.4±0.2 | 14.95±0.35 | 14.3±0.3 |

| Part No. | Effective parameter | | | | | Electrical characteristics | | |
|------------|---|---|---|--|---------------|--|------------------|---|
| | Core factor C ₁ (mm ⁻¹) | Effective cross-sectional area A _e (mm ²) | Effective magnetic path length ℓ _e (mm) | Effective core volume V _e (mm ³) | Weight (g) | AL-value (nH/N ²) 1kHz 0.5mA 100Ts Without air gap With air gap | | Core loss (W) max. 100kHz 200mT 100°C |
| PC47EP7-Z | 1.52 | 10.3 | 15.7 | 162 | 1.4 | 830 min. | 63±3% 100±4% | 0.058 |
| PC47EP10-Z | 1.70 | 11.3 | 19.2 | 217 | 2.8 | 800 min. 800±25% | 63±3% 100±4% | 0.071 |
| PC47EP13-Z | 1.24 | 19.5 | 24.2 | 472 | 5.1 | 1170 min. 1100±25% | 100±3% 160±3% | 0.155 |
| PC47EP17-Z | 0.84 | 33.9 | 28.5 | 966 | 12 | 1840 min. | 100±5% 250±7% | 0.306 |
| PC47EP20-Z | 0.508 | 78 | 39.8 | 3120 | 28 | 3200 min. | 100±5% 250±7% | 1.027 |

• All specifications are subject to change without notice.

Mn-Zn

Ferrite Cores for Switching Power Supplies

EPC series

 **REMINDERS FOR USING THESE PRODUCTS**

Please be sure to read this manual thoroughly before using the products.

The products listed on this catalog are intended for use in general electronic equipment (AV equipment, telecommunications equipment, home appliances, amusement equipment, computer equipment, personal equipment, office equipment, measurement equipment, industrial robots) under a normal operation and use condition.

The products are not designed or warranted to meet the requirements of the applications listed below, whose performance and/or quality require a more stringent level of safety or reliability, or whose failure, malfunction or trouble could cause serious damage to society, person or property.

When using the products for specific purposes, please first make confirmations in areas such as safety, reliability, and quality.

Please understand that we are not in a position to be held responsible for any damage or the like caused by any use exceeding the range or conditions of this specification sheet or by any use in the specific applications.

- | | |
|---|--|
| (1) Aerospace/Aviation equipment | (8) Public information-processing equipment |
| (2) Transportation equipment (electric trains, ships, etc.) | (9) Military equipment |
| (3) Medical equipment | (10) Electric heating apparatus, burning equipment |
| (4) Power-generation control equipment | (11) Disaster prevention/crime prevention equipment |
| (5) Atomic energy-related equipment | (12) Safety equipment |
| (6) Seabed equipment | (13) Other applications that are not considered general-purpose applications |
| (7) Transportation control equipment | |

When using this product in general-purpose standard applications, you are kindly requested to take into consideration securing protection circuit/equipment or providing backup circuits, etc to ensure higher safety.

Ferrite Cores for Switching Power Supplies

Product compatible with RoHS directive
Halogen-free

Overview of the EPC Series

FEATURES

- TDK's original shapes
- The EPC Cores have low profiles, and so are useful in situations where mounting is subject to restrictions.

APPLICATION

Transformers and coils for Switched-mode power supplies (High Mounting Density, Low Profile)

PART NUMBER CONSTRUCTION

| PC47 | EPC10 | Z | - | 1 | 2 |
|----------|------------------|----------------------------------|---|-------------------|---------------------|
| Material | Size of EPC core | AL-value (Z: without air gap) | | Type | Number of lead slot |
| PC47 | EPC10 | | | 1 Without air gap | |
| PC90 | EPC13 | | | 2 With air gap | |
| PC95 | EPC17 | | | | |
| | EPC19 | | | | |
| | EPC25 | | | | |
| | EPC25B | | | | |
| | EPC27 | | | | |
| | EPC30 | | | | |

RANGE OF USE AND STORAGE TEMPERATURE

| Temperature range | |
|-------------------------------|-----------------------------|
| Operating temperature (°C) | Storage temperature (°C) |
| -30 to +105 | -30 to +85 |

- RoHS Directive Compliant Product: See the following for more details related to RoHS Directive compliant products. <http://www.tdk.co.jp/rohs/>
- Halogen-free: Indicates that Cl content is less than 900ppm, Br content is less than 900ppm, and that the total Cl and Br content is less than 1500ppm.

• All specifications are subject to change without notice.

Mn-Zn EPC Core

SHAPES AND DIMENSIONS

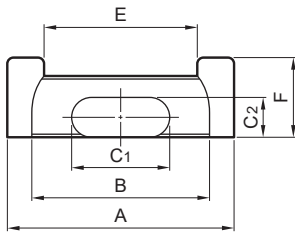

Fig. 1

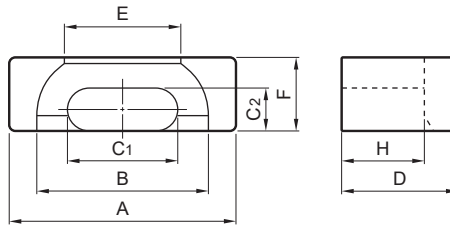

Fig. 2

| | | | | | |
|----------|------------------|-------------------------------|---|-------------------|---------------------|
| PC47 | EPC10 | Z | - | 1 | 2 |
| Material | Size of EPC core | AL-value (Z: without air gap) | | Type | Number of lead slot |
| | | | | 1 Without air gap | |
| | | | | 2 With air gap | |

| Part No. | Core | Dimensions (mm) | | | | | | | |
|---|-------|-----------------|--------|-----------|-----------|-----------|--------|-----------|-----------|
| | | A | B min. | C1 | C2 | D | E min. | F | H |
| PC47EPC10-Z PC90EPC10-Z PC95EPC10-Z | Fig.2 | 10.2±0.2 | 7.6 | 5.0±0.1 | 1.9±0.1 | 4.05±0.10 | 5.3 | 3.4±0.1 | 2.65±0.10 |
| PC47EPC13-Z PC90EPC13-Z PC95EPC13-Z | Fig.1 | 13.25±0.3 | 10.5 | 5.60±0.15 | 2.05±0.10 | 6.6±0.2 | 8.3 | 4.60±0.15 | 4.5±0.2 |
| PC47EPC17-Z PC90EPC17-Z PC95EPC17-Z | Fig.1 | 17.6±0.4 | 14.3 | 7.70±0.15 | 2.8±0.1 | 8.55±0.20 | 11.5 | 6.00±0.15 | 6.05±0.20 |
| PC47EPC19-Z PC90EPC19-Z PC95EPC19-Z | Fig.1 | 19.1±0.4 | 15.8 | 8.50±0.15 | 2.5±0.1 | 9.75±0.20 | 13.1 | 6.00±0.15 | 7.25±0.20 |

| Part No. | Effective parameter | | | | | Electrical characteristics | | | | | | |
|---|---|---|---|--|--------------|--|--------------|----------------------------|-------|-------|------|-------|
| | Core factor C ₁ (mm ⁻¹) | Effective cross-sectional area A _e (mm ²) | Effective magnetic path length ℓ _e (mm) | Effective core volume V _e (mm ³) | Weigh (g) | AL-value | | Core loss | | | | |
| | | | | | | (nH/N ²) 1kHz 0.5mA 100Ts | | (W)max. 100kHz 200mT | 100°C | 25°C | 80°C | 120°C |
| PC47EPC10-Z PC90EPC10-Z PC95EPC10-Z | 1.89 | 9.39 | 17.8 | 167 | 1.1 | Without air gap | With air gap | 0.067 | — | — | — | |
| 1000±25% | | | | | | 40±7% | 0.090 | — | — | — | | |
| 900±25% | | | | | | 63±10% | — | 0.100 | 0.080 | 0.100 | | |
| PC47EPC13-Z PC90EPC13-Z PC95EPC13-Z | 2.45 | 12.5 | 30.6 | 382 | 2.1 | Without air gap | With air gap | 0.14 | — | — | — | |
| 870±25% | | | | | | 40±4% | 0.17 | — | — | — | | |
| 800±25% | | | | | | 63±5% | — | 0.17 | 0.15 | 0.17 | | |
| PC47EPC17-Z PC90EPC17-Z PC95EPC17-Z | 1.76 | 22.8 | 40.2 | 917 | 4.5 | Without air gap | With air gap | 0.34 | — | — | — | |
| 1150±25% | | | | | | 80±4% | 0.45 | — | — | — | | |
| 1100±25% | | | | | | 125±5% | — | 0.45 | 0.35 | 0.45 | | |
| PC47EPC19-Z PC90EPC19-Z PC95EPC19-Z | 2.03 | 22.7 | 46.1 | 1050 | 5.3 | Without air gap | With air gap | 0.39 | — | — | — | |
| 940±25% | | | | | | 80±4% | 0.5 | — | — | — | | |
| 940±25% | | | | | | 125±5% | — | 0.5 | 0.4 | 0.5 | | |

• All specifications are subject to change without notice.

Mn-Zn EPC Cores

SHAPES AND DIMENSIONS

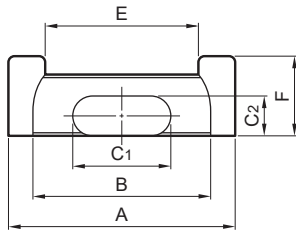

Fig. 1

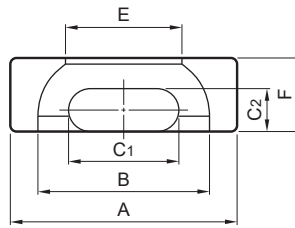
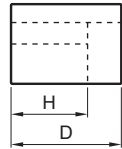

Fig. 2

| | | | | | |
|----------|------------------|-------------------------------|---|-------------------|---------------------|
| PC47 | EPC25 | Z | - | 1 | 2 |
| Material | Size of EPC core | AL-value (Z: without air gap) | | Type | Number of lead slot |
| | | | | 1 Without air gap | |
| | | | | 2 With air gap | |

| Part No. | Core | Dimensions (mm) | | | | | | | |
|--|-------|-----------------|--------|----------------|----------------|------------|--------|---------|-----------|
| | | A | B min. | C ₁ | C ₂ | D | E min. | F | H |
| PC47EPC25-Z PC90EPC25-Z PC95EPC25-Z | Fig.1 | 25.1±0.5 | 20.65 | 11.5±0.2 | 4.0±0.1 | 12.5±0.2 | 17.1 | 8.0±0.2 | 9.0±0.3 |
| PC47EPC25B-Z PC90EPC25B-Z PC95EPC25B-Z | Fig.2 | 25.1±0.5 | 20.4 | 13.8±0.2 | 2.50±0.15 | 11.43±0.15 | 16.5 | 6.5±0.2 | 8.78±0.15 |
| PC47EPC27-Z PC90EPC27-Z PC95EPC27-Z | Fig.1 | 27.1±0.5 | 21.6 | 13.0±0.3 | 4.0±0.1 | 16.0±0.2 | 18.5 | 8.0±0.2 | 12.0±0.3 |
| PC47EPC30-Z PC90EPC30-Z PC95EPC30-Z | Fig.1 | 30.1±0.5 | 23.6 | 15.0±0.3 | 4.0±0.1 | 17.5±0.2 | 20.0 | 8.0±0.2 | 13.0±0.3 |

| Part No. | Effective parameter | | | | | Electrical characteristics | | | | | | |
|--|---|---|---|--|--------------|---|------------------|----------------------------|-----------------|----------------|---------------|-------|
| | Core factor C _i (mm ⁻¹) | Effective cross-sectional area A _e (mm ²) | Effective magnetic path length ℓ _e (mm) | Effective core volume V _e (mm ³) | Weigh (g) | AL-value | | Core loss | | | | |
| | | | | | | (nH/N ²) 1kHz 0.5mA 100Ts Without air gap | With air gap | (W)max. 100kHz 200mT | 100°C | 25°C | 80°C | 120°C |
| PC47EPC25-Z PC90EPC25-Z PC95EPC25-Z | 1.40 | 40.4 | 56.3 | 2280 | 13 | 1560±25% 1400±25% 2200±25% | 125±5% 200±7% | 1.08 1.4 — | — 1.4 1.4 | — — 1.2 | — — 1.4 | |
| PC47EPC25B-Z PC90EPC25B-Z PC95EPC25B-Z | 1.39 | 33.3 | 46.2 | 1540 | 11 | 1560±25% 1400±25% 2200±25% | 80±5% 125±7% | 0.64 0.8 — | — 0.8 0.8 | — — 0.65 | — — 0.8 | |
| PC47EPC27-Z PC90EPC27-Z PC95EPC27-Z | 1.43 | 48.6 | 69.4 | 3370 | 18 | 1540±25% 1400±25% 2200±25% | 125±5% 200±7% | 1.53 2.0 — | — 2.0 2.0 | — — 1.7 | — — 2.0 | |
| PC47EPC30-Z PC90EPC30-Z PC95EPC30-Z | 1.35 | 55.6 | 75.3 | 4190 | 23 | 1570±25% 1700±25% 2300±25% | 125±5% 200±7% | 1.99 2.5 — | — — 2.3 | — — 2.0 | — — 2.3 | |

• All specifications are subject to change without notice.

Mn-Zn EPC series **Part No.: PC47EPC10-Z**

SHAPES AND DIMENSIONS

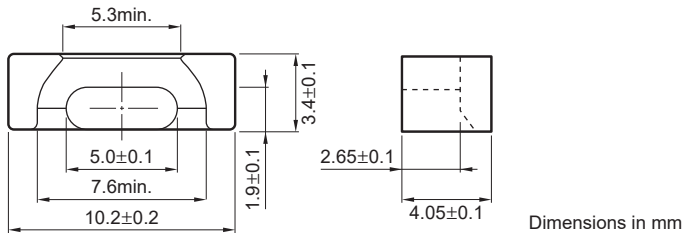

| Effective parameter | | | | | | | | Electrical characteristics | |
|---------------------|---|---|--|--|---|--|----------------|---------------------------------------|--------------------------------------|
| Core factor | Effective magnetic path length l_e (mm) | Effective cross-sectional area A_e (mm ²) | Effective core volume V_e (mm ³) | Cross-sectional center pole area A_{cp} (mm ²) | Minimum cross-sectional center pole area $A_{cp \text{ min.}}$ (mm ²) | Cross-sectional winding area of core A_{cw} (mm ²) | Weight (g/set) | AL-value * (nH/N ²) | Core loss (W)max. 100kHz 200mT 100°C |
| C ₁ | (mm ⁻¹) | (mm) | (mm ³) | (mm ²) | (mm ²) | (mm ²) | (g/set) | (nH/N ²) 1kHz 0.5mA | (W)max. 100kHz 200mT 100°C |
| 1.89 | 17.8 | 9.39 | 167 | 8.73 | 8.13 | 7.69 | 1.1 | 1000±25% | 0.067 |

* Coil : ø0.1 2UEW 100Ts

○ Calculated output power (forward converter mode): 5.8W (100kHz)

NI limit vs. AL-value (Typ.)

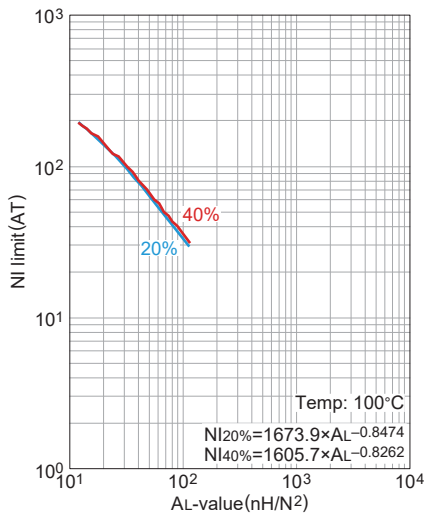

The 20% and 40% graph shows when a 20% and 40% drop from the initial AL-value has been made due to the DC superimposition.

AL-value vs. Air gap length (Typ.)

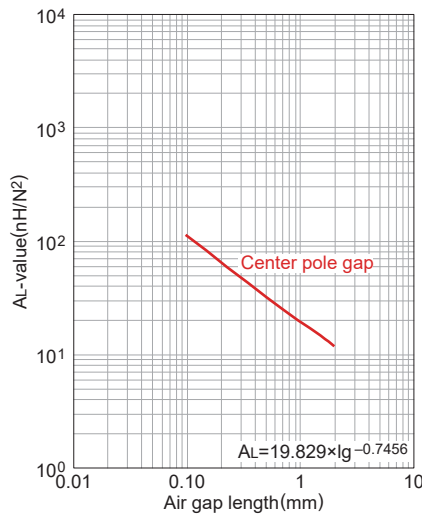

Measuring conditions

- Coil : ø0.1 2UEW 100Ts
- Frequency : 1kHz
- Current level : 0.5mA
- Ambient temperature : 25°C

Temperature rise vs. Total loss (Typ.)

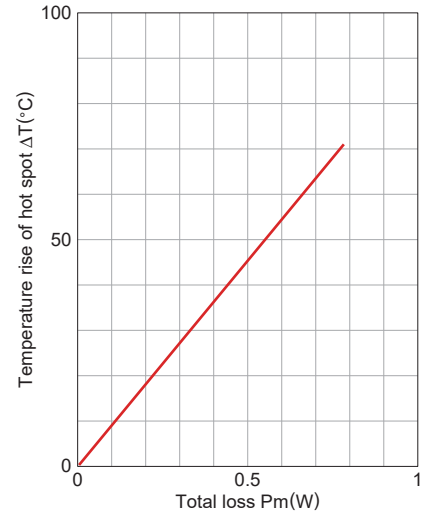

Measuring conditions

- Room space: approx. 400x300x 300cm
- Ambient temperature : 25°C
- Humidity : 45%(%)RH.

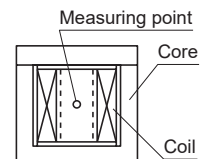

Mn-Zn EPC series Part No.: PC90EPC10-Z

SHAPES AND DIMENSIONS

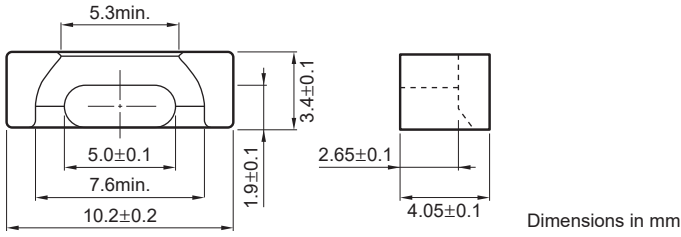

| Effective parameter | | | | | | | | Electrical characteristics | |
|------------------------------|--------------------------------------|--------------------------------------|-----------------------------|---|--|---|---------|---------------------------------------|-------------------------------------|
| Core factor | Effective magnetic path length l_e | Effective cross-sectional area A_e | Effective core volume V_e | Cross-sectional center pole area A_{cp} | Minimum cross-sectional center pole area $A_{cp \text{ min.}}$ | Cross-sectional winding area of core A_{cw} | Weight | AL-value * | Core loss |
| C_1 (mm ⁻¹) | (mm) | (mm ²) | (mm ³) | (mm ²) | (mm ²) | (mm ²) | (g/set) | (nH/N ²) 1kHz 0.5mA | (W)max. 100kHz 200mT 100°C |
| 1.89 | 17.8 | 9.39 | 167 | 8.73 | 8.13 | 7.69 | 1.1 | 900±25% | 0.090 |

*Coil : ø0.1 2UEW 100Ts

○ Calculated output power (forward converter mode): 5.4W

NI limit vs. AL-value (Typ.)

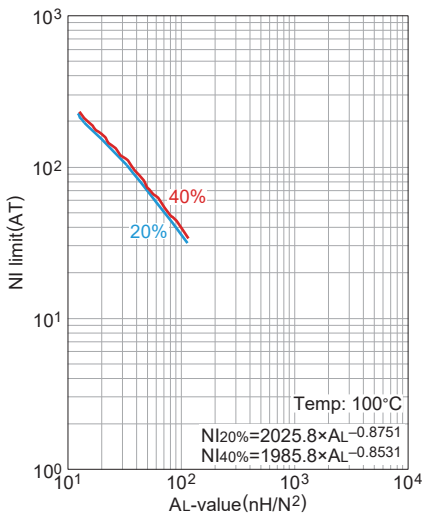

The 20% and 40% graph shows when a 20% and 40% drop from the initial AL-value has been made due to the DC superimposition.

AL-value vs. Air gap length (Typ.)

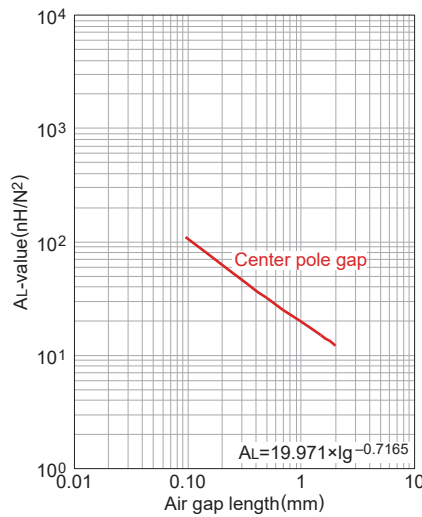

Measuring conditions

- Coil : ø0.1 2UEW 100Ts
- Frequency : 1kHz
- Current level : 0.5mA
- Ambient temperature : 25°C

Temperature rise vs. Total loss (Typ.)

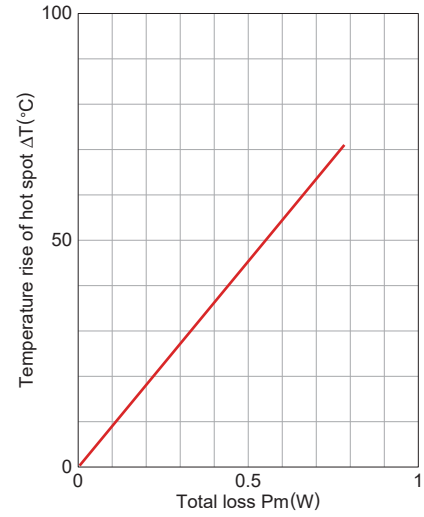

Measuring conditions

- Room space: approx. 400x300x 300cm
- Ambient temperature : 25°C
- Humidity: 45%(%)RH.

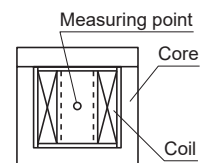

Mn-Zn EPC series **Part No.: PC95EPC10-Z**

SHAPES AND DIMENSIONS

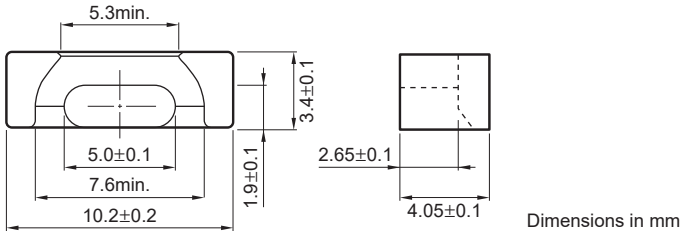

| Effective parameter | | | | | | | | Electrical characteristics | | | | | |
|---------------------|--------------------------------------|--------------------------------------|-----------------------------|---|--|---|----------------|----------------------------|-----------|------|-------|-------|-------|
| Core factor | Effective magnetic path length l_e | Effective cross-sectional area A_e | Effective core volume V_e | Cross-sectional center pole area A_{cp} | Minimum cross-sectional center pole area $A_{cp \text{ min.}}$ | Cross-sectional winding area of core A_{cw} | Weight (g/set) | AL-value * | Core loss | | | | |
| C_1 | (mm) | (mm ²) | (mm ³) | (mm ²) | (mm ²) | (mm ²) | (g/set) | (nH/N ²) | (W)max. | | | | |
| 1.89 | 17.8 | 9.39 | 167 | 8.73 | 8.13 | 7.69 | 1.1 | 1040±25% | 100kHz | 80°C | 120°C | | |
| | | | | | | | | | 0.5mA | 25°C | 0.100 | 0.080 | 0.100 |

*Coil : ø0.1 2UEW 100Ts
 ○ Calculated output power (forward converter mode): 5.6W

NI limit vs. AL-value (Typ.)

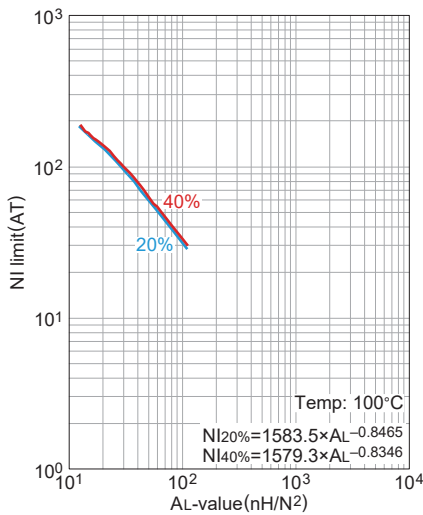

The 20% and 40% graph shows when a 20% and 40% drop from the initial AL-value has been made due to the DC superimposition.

AL-value vs. Air gap length (Typ.)

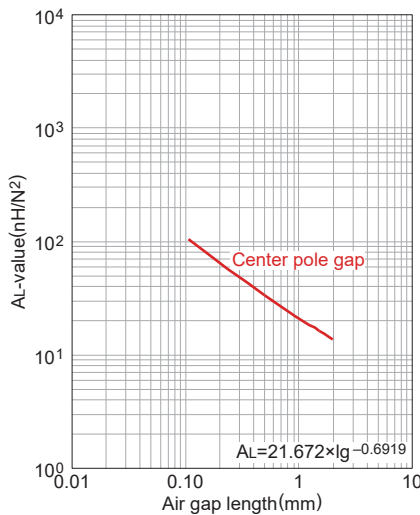

Measuring conditions
 • Coil : ø0.1 2UEW 100Ts
 • Frequency : 1kHz
 • Current level : 0.5mA
 • Ambient temperature : 25°C

Temperature rise vs. Total loss (Typ.)

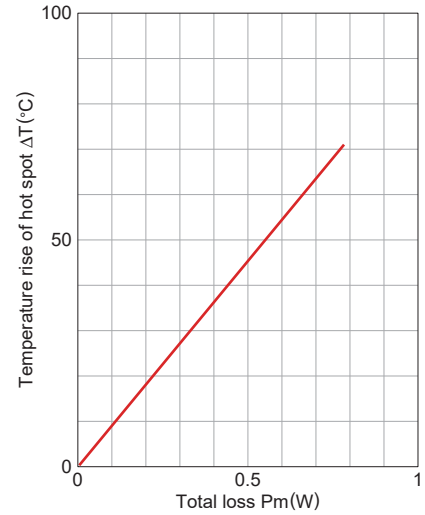

Measuring conditions
 • Room space: approx. 400x300x 300cm
 • Ambient temperature : 25°C
 • Humidity: 45(%)RH.

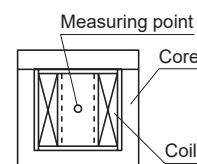

• All specifications are subject to change without notice.

Mn-Zn EPC series Part No.: PC47EPC13-Z

SHAPES AND DIMENSIONS

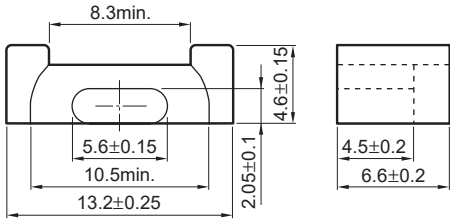

Dimensions in mm

| Effective parameter | | | | | | | | Electrical characteristics | |
|------------------------------|--------------------------------------|--------------------------------------|-----------------------------|---|--|---|---------|---------------------------------------|-------------------------------------|
| Core factor | Effective magnetic path length l_e | Effective cross-sectional area A_e | Effective core volume V_e | Cross-sectional center pole area A_{cp} | Minimum cross-sectional center pole area $A_{cp \text{ min.}}$ | Cross-sectional winding area of core A_{cw} | Weight | AL-value * | Core loss |
| C_1 (mm ⁻¹) | (mm) | (mm ²) | (mm ³) | (mm ²) | (mm ²) | (mm ²) | (g/set) | (nH/N ²) 1kHz 0.5mA | (W)max. 100kHz 200mT 100°C |
| 2.45 | 30.6 | 12.5 | 382 | 10.6 | 9.71 | 23.0 | 2.1 | 870±25% | 0.14 |

* Coil : ø0.2 2UEW 100Ts

○ Calculated output power (forward converter mode): 9.1W (100kHz)

NI limit vs. AL-value (Typ.)

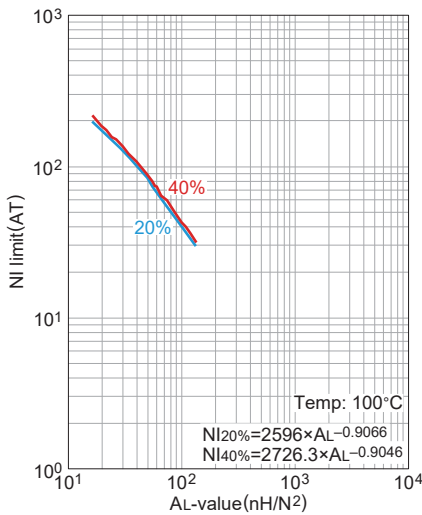

The 20% and 40% graph shows when a 20% and 40% drop from the initial AL-value has been made due to the DC superimposition.

AL-value vs. Air gap length (Typ.)

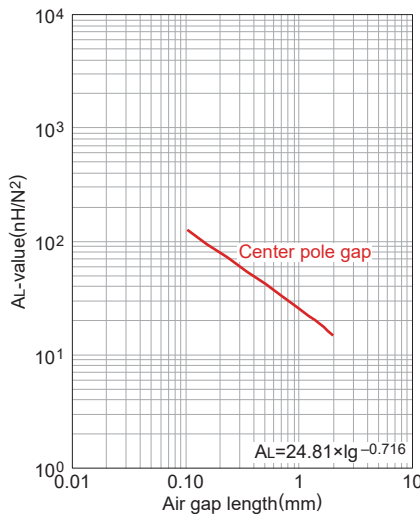

Measuring conditions

- Coil : ø0.2 2UEW 100Ts
- Frequency : 1kHz
- Current level : 0.5mA
- Ambient temperature : 25°C

Temperature rise vs. Total loss (Typ.)

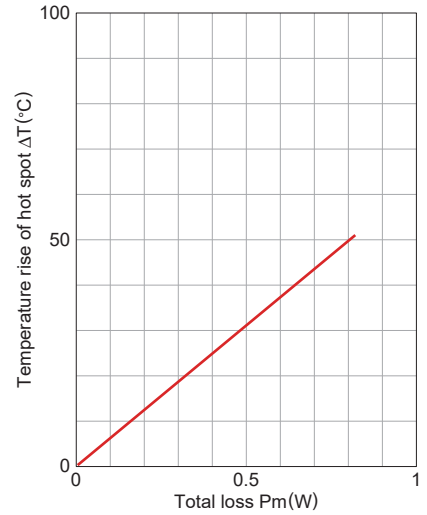

Measuring conditions

- Room space: approx. 400x300x 300cm
- Ambient temperature : 25°C
- Humidity: 45%(%)RH.

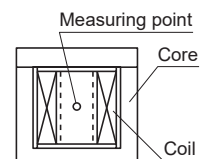

* All specifications are subject to change without notice.

Mn-Zn EPC series **Part No.: PC90EPC13-Z**

SHAPES AND DIMENSIONS

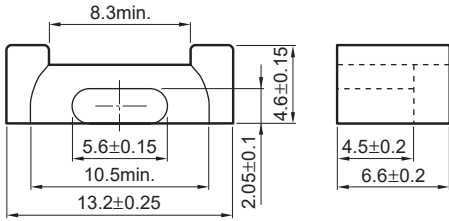

Dimensions in mm

| Effective parameter | | | | | | | | Electrical characteristics | |
|------------------------|---|---|--|--|---|--|----------------|---------------------------------|--------------------------------------|
| Core factor | Effective magnetic path length l_e (mm) | Effective cross-sectional area A_e (mm ²) | Effective core volume V_e (mm ³) | Cross-sectional center pole area A_{cp} (mm ²) | Minimum cross-sectional center pole area $A_{cp \text{ min.}}$ (mm ²) | Cross-sectional winding area of core A_{cw} (mm ²) | Weight (g/set) | AL-value * (nH/N ²) | Core loss (W)max. 100kHz 200mT 100°C |
| C1 (mm ⁻¹) | 30.6 | 12.5 | 382 | 10.6 | 9.71 | 23.0 | 2.1 | 800±25% | 0.17 |

* Coil : ø0.2 2UEW 100Ts

○ Calculated output power (forward converter mode): 8.6W

NI limit vs. AL-value (Typ.)

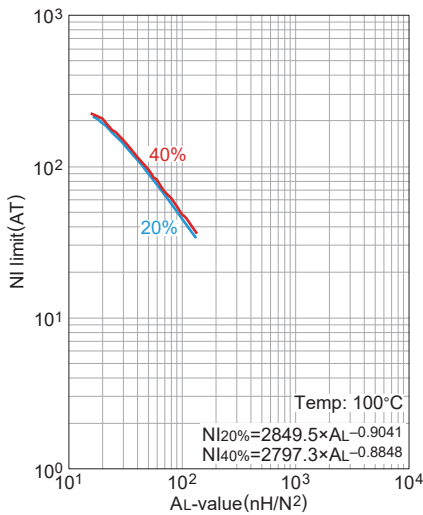

The 20% and 40% graph shows when a 20% and 40% drop from the initial AL-value has been made due to the DC superimposition.

AL-value vs. Air gap length (Typ.)

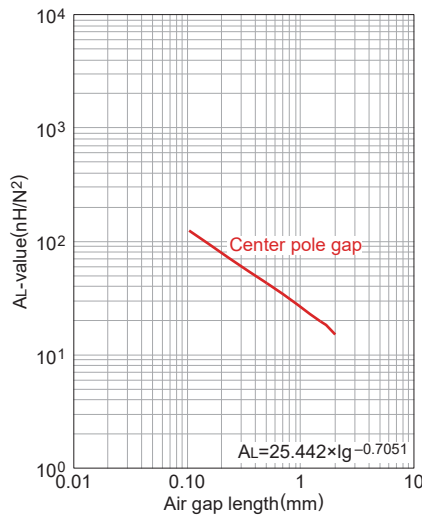

Measuring conditions

- Coil : ø0.2 2UEW 100Ts
- Frequency : 1kHz
- Current level : 0.5mA
- Ambient temperature : 25°C

Temperature rise vs. Total loss (Typ.)

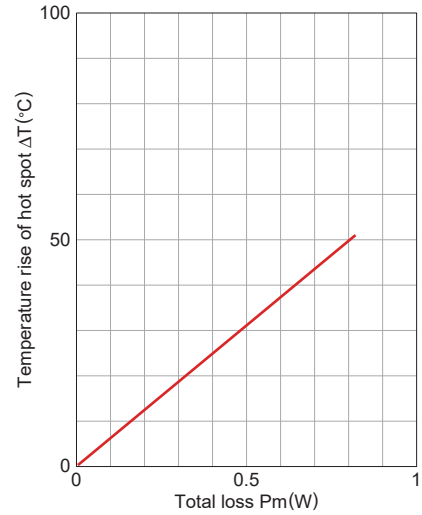

Measuring conditions

- Room space: approx. 400x300x 300cm
- Ambient temperature : 25°C
- Humidity : 45(%RH).

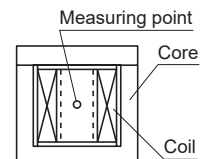

• All specifications are subject to change without notice.

Mn-Zn EPC series **Part No.: PC95EPC13-Z**

SHAPES AND DIMENSIONS

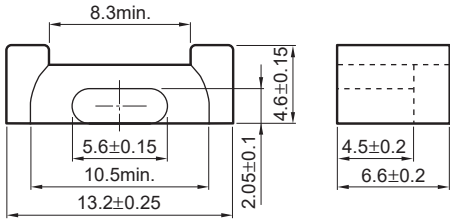

Dimensions in mm

| Effective parameter | | | | | | | | Electrical characteristics | | | | | |
|---------------------|---|---|--|--|---|--|----------------|---------------------------------|-------------------|-------|------|------|-------|
| Core factor | Effective magnetic path length l_e (mm) | Effective cross-sectional area A_e (mm ²) | Effective core volume V_e (mm ³) | Cross-sectional center pole area A_{cp} (mm ²) | Minimum cross-sectional center pole area $A_{cp \text{ min.}}$ (mm ²) | Cross-sectional winding area of core A_{cw} (mm ²) | Weight (g/set) | AL-value * (nH/N ²) | Core loss (W)max. | | | | |
| C ₁ | (mm ⁻¹) | (mm) | (mm ³) | (mm ²) | (mm ²) | (mm ²) | (g/set) | (nH/N ²) | 100kHz | 200mT | 25°C | 80°C | 120°C |
| 2.45 | 30.6 | 12.5 | 382 | 10.6 | 9.71 | 23.0 | 2.1 | 1060±25% | 0.17 | 0.15 | 0.17 | | |

* Coil : ø0.2 2UEW 100Ts

○ Calculated output power (forward converter mode): 8.8W

NI limit vs. AL-value (Typ.)

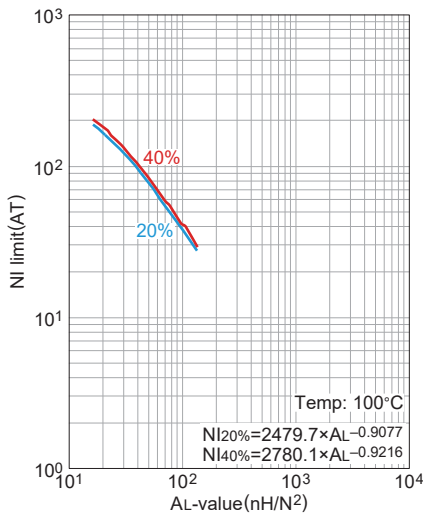

The 20% and 40% graph shows when a 20% and 40% drop from the initial AL-value has been made due to the DC superimposition.

AL-value vs. Air gap length (Typ.)

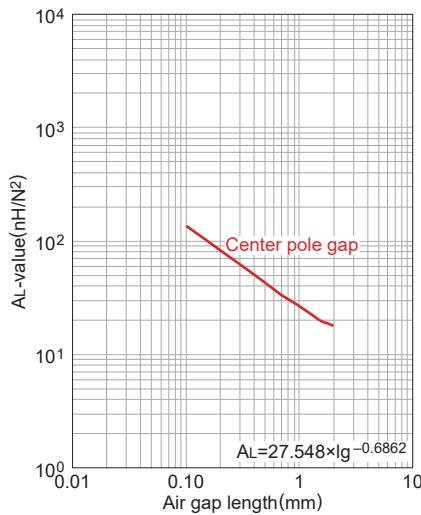

Measuring conditions
 • Coil : ø0.2 2UEW 100Ts
 • Frequency : 1kHz
 • Current level : 0.5mA
 • Ambient temperature : 25°C

Temperature rise vs. Total loss (Typ.)

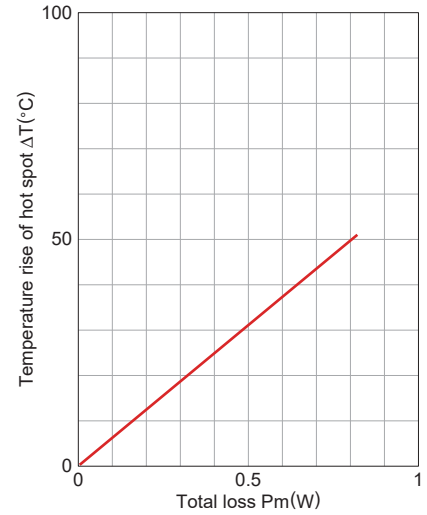

Measuring conditions
 • Room space: approx. 400x300x 300cm
 • Ambient temperature : 25°C
 • Humidity : 45%(%)RH.

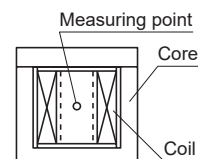

Mn-Zn EPC series Part No.: PC47EPC17-Z

SHAPES AND DIMENSIONS

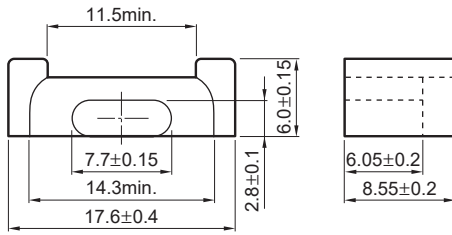

Dimensions in mm

| Effective parameter | | | | | | | | Electrical characteristics | |
|------------------------------|--------------------------------------|--------------------------------------|-----------------------------|---|--|---|---------|---------------------------------------|-------------------------------------|
| Core factor | Effective magnetic path length l_e | Effective cross-sectional area A_e | Effective core volume V_e | Cross-sectional center pole area A_{cp} | Minimum cross-sectional center pole area $A_{cp \text{ min.}}$ | Cross-sectional winding area of core A_{cw} | Weight | AL-value * | Core loss |
| C_1 (mm ⁻¹) | (mm) | (mm ²) | (mm ³) | (mm ²) | (mm ²) | (mm ²) | (g/set) | (nH/N ²) 1kHz 0.5mA | (W)max. 100kHz 200mT 100°C |
| 1.76 | 40.2 | 22.8 | 917 | 19.9 | 18.7 | 41.1 | 4.5 | 1150±25% | 0.34 |

* Coil : $\phi 0.2$ 2UEW 100Ts

○ Calculated output power (forward converter mode): 21.9W (100kHz)

NI limit vs. AL-value (Typ.)

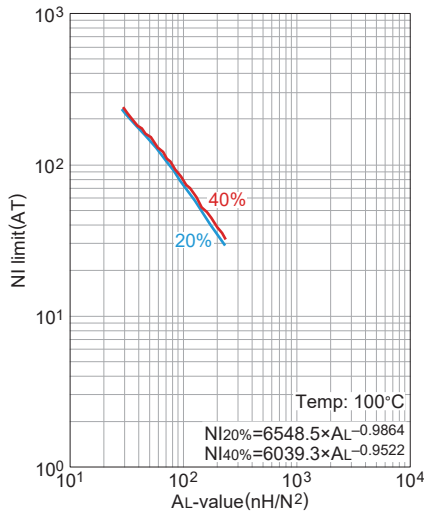

The 20% and 40% graph shows when a 20% and 40% drop from the initial AL-value has been made due to the DC superimposition.

AL-value vs. Air gap length (Typ.)

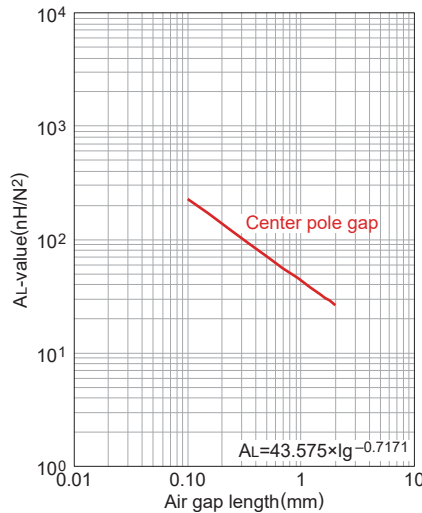

Measuring conditions

- Coil : $\phi 0.2$ 2UEW 100Ts
- Frequency : 1kHz
- Current level : 0.5mA
- Ambient temperature : 25°C

Temperature rise vs. Total loss (Typ.)

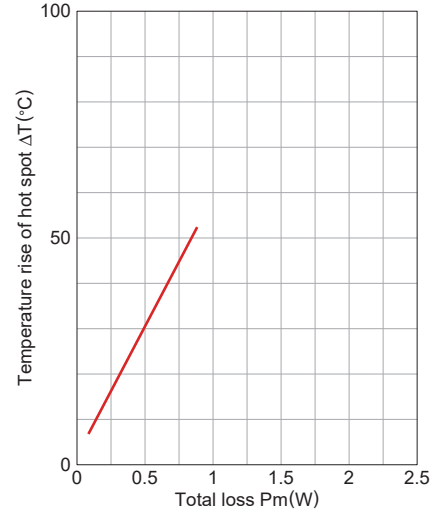

Measuring conditions

- Room space: approx. 400x300x 300cm
- Ambient temperature : 25°C
- Humidity : 45(%RH).

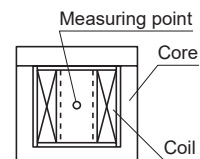

* All specifications are subject to change without notice.

Mn-Zn EPC series **Part No.: PC90EPC17-Z**

SHAPES AND DIMENSIONS

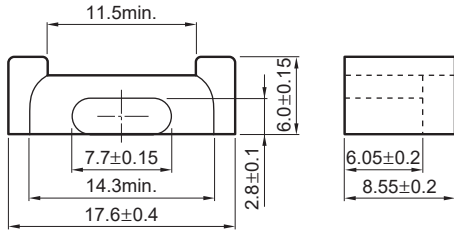

Dimensions in mm

| Effective parameter | | | | | | | | Electrical characteristics | |
|---------------------|---|---|--|--|---|--|----------------|---------------------------------|--------------------------------------|
| Core factor | Effective magnetic path length l_e (mm) | Effective cross-sectional area A_e (mm ²) | Effective core volume V_e (mm ³) | Cross-sectional center pole area A_{cp} (mm ²) | Minimum cross-sectional center pole area $A_{cp \text{ min.}}$ (mm ²) | Cross-sectional winding area of core A_{cw} (mm ²) | Weight (g/set) | AL-value * (nH/N ²) | Core loss (W)max. 100kHz 200mT 100°C |
| 1.76 | 40.2 | 22.8 | 917 | 19.9 | 18.7 | 41.1 | 4.5 | 1100±25% | 0.45 |

* Coil : $\phi 0.2$ 2UEW 100Ts

○ Calculated output power (forward converter mode): 20.5W

NI limit vs. AL-value (Typ.)

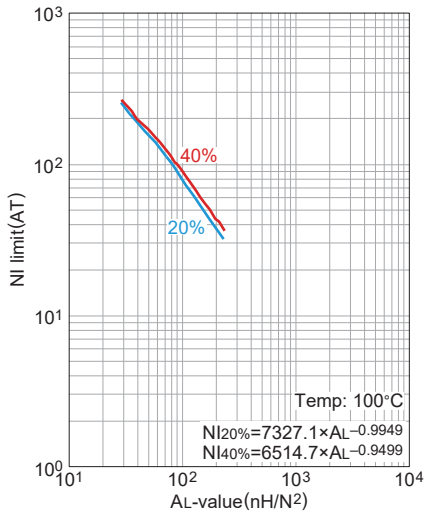

The 20% and 40% graph shows when a 20% and 40% drop from the initial AL-value has been made due to the DC superimposition.

AL-value vs. Air gap length (Typ.)

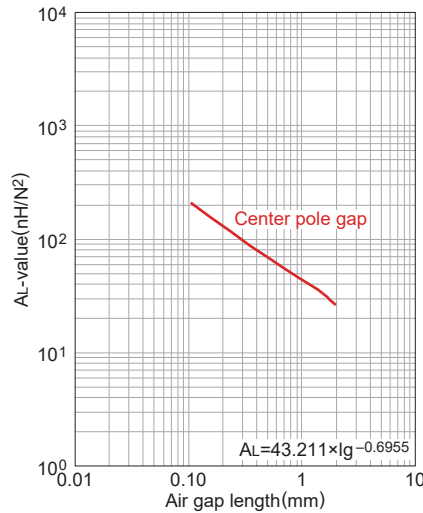

Measuring conditions

- Coil : $\phi 0.2$ 2UEW 100Ts
- Frequency : 1kHz
- Current level : 0.5mA
- Ambient temperature : 25°C

Temperature rise vs. Total loss (Typ.)

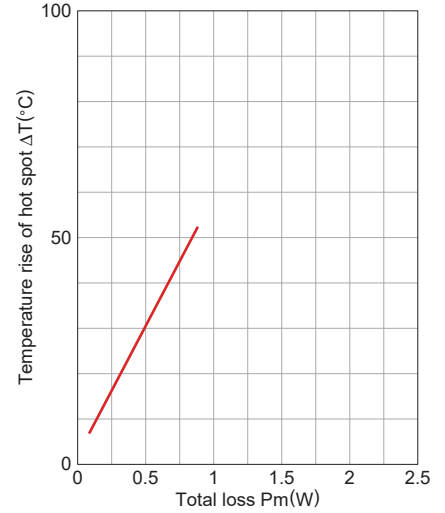

Measuring conditions

- Room space: approx. 400x300x 300cm
- Ambient temperature : 25°C
- Humidity: 45%(%)RH.

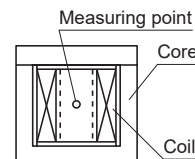

• All specifications are subject to change without notice.

Mn-Zn EPC series Part No.: PC95EPC17-Z

SHAPES AND DIMENSIONS

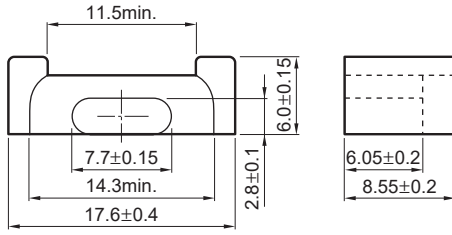

Dimensions in mm

| Effective parameter | | | | | | | | Electrical characteristics | | | |
|---------------------------|---|---|--|--|---|--|----------------|---------------------------------|-------------------|------|-------|
| Core factor | Effective magnetic path length l_e (mm) | Effective cross-sectional area A_e (mm ²) | Effective core volume V_e (mm ³) | Cross-sectional center pole area A_{cp} (mm ²) | Minimum cross-sectional center pole area $A_{cp \text{ min.}}$ (mm ²) | Cross-sectional winding area of core A_{cw} (mm ²) | Weight (g/set) | AL-value * (nH/N ²) | Core loss (W)max. | | |
| C_1 (mm ⁻¹) | | | | | | | | 1kHz 0.5mA | 25°C | 80°C | 120°C |
| 1.76 | 40.2 | 22.8 | 917 | 19.9 | 18.7 | 41.1 | 4.5 | 1500±25% | 0.45 | 0.35 | 0.45 |

* Coil : $\phi 0.2$ 2UEW 100Ts

○ Calculated output power (forward converter mode): 21.1W

NI limit vs. AL-value (Typ.)

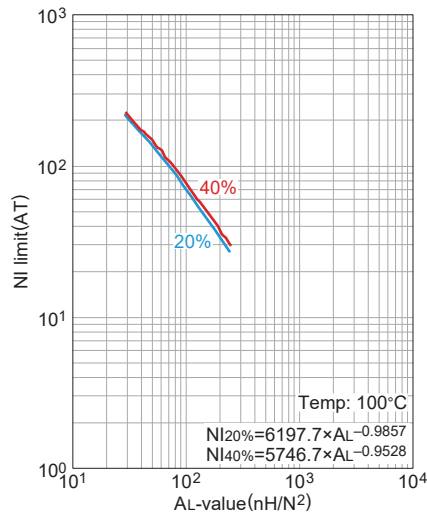

The 20% and 40% graph shows when a 20% and 40% drop from the initial AL-value has been made due to the DC superimposition.

AL-value vs. Air gap length (Typ.)

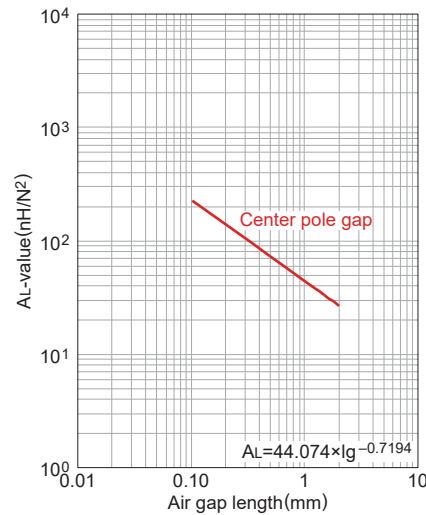

Measuring conditions

- Coil : $\phi 0.2$ 2UEW 100Ts
- Frequency : 1kHz
- Current level : 0.5mA
- Ambient temperature : 25°C

Temperature rise vs. Total loss (Typ.)

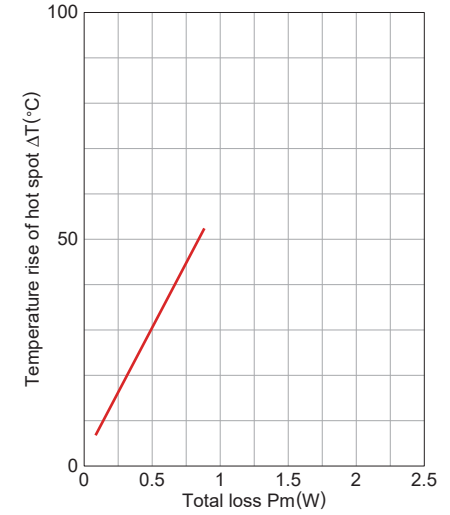

Measuring conditions

- Room space: approx. 400x300x 300cm
- Ambient temperature : 25°C
- Humidity: 45%(%)RH.

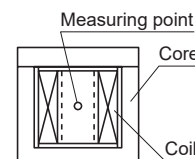

• All specifications are subject to change without notice.

Mn-Zn EPC series Part No.: PC47EPC19-Z

SHAPES AND DIMENSIONS

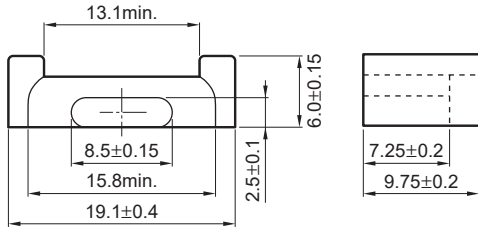

Dimensions in mm

| Effective parameter | | | | | | | | Electrical characteristics | |
|------------------------------|--------------------------------------|--------------------------------------|-----------------------------|---|--|---|---------|---------------------------------------|-------------------------------------|
| Core factor | Effective magnetic path length l_e | Effective cross-sectional area A_e | Effective core volume V_e | Cross-sectional center pole area A_{cp} | Minimum cross-sectional center pole area $A_{cp \text{ min.}}$ | Cross-sectional winding area of core A_{cw} | Weight | AL-value * | Core loss |
| C_1 (mm ⁻¹) | (mm) | (mm ²) | (mm ³) | (mm ²) | (mm ²) | (mm ²) | (g/set) | (nH/N ²) 1kHz 0.5mA | (W)max. 100kHz 200mT 100°C |
| 2.03 | 46.1 | 22.7 | 1050 | 19.9 | 18.7 | 54.4 | 5.3 | 940±25% | 0.39 |

*Coil : ø0.2 2UEW 100Ts

○ Calculated output power (forward converter mode): 29.9W (100kHz)

NI limit vs. AL-value (Typ.)

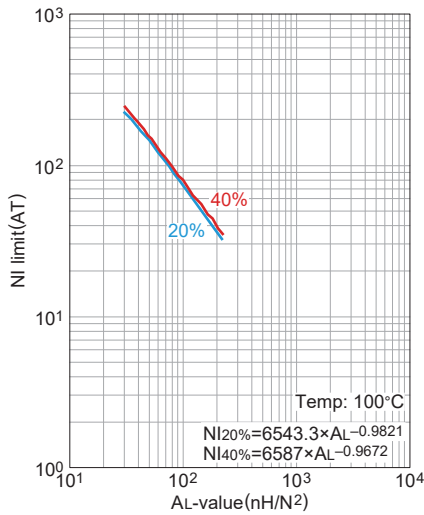

The 20% and 40% graph shows when a 20% and 40% drop from the initial AL-value has been made due to the DC superimposition.

AL-value vs. Air gap length (Typ.)

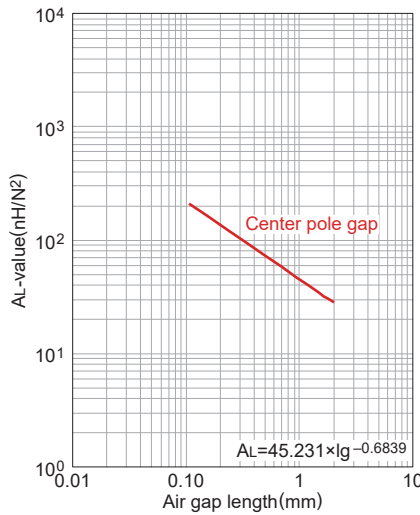

Measuring conditions

- Coil : ø0.2 2UEW 100Ts
- Frequency : 1kHz
- Current level : 0.5mA
- Ambient temperature : 25°C

Temperature rise vs. Total loss (Typ.)

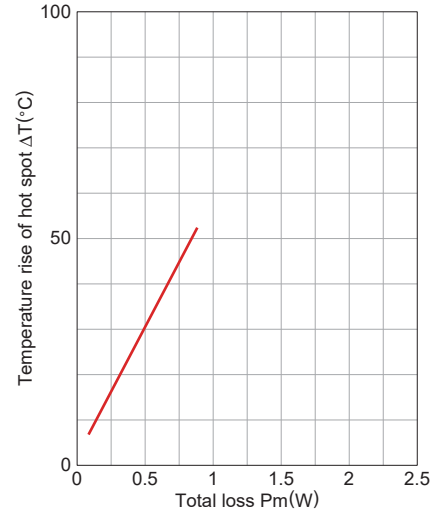

Measuring conditions

- Room space: approx. 400x300x 300cm
- Ambient temperature : 25°C
- Humidity: 45%(%)RH.

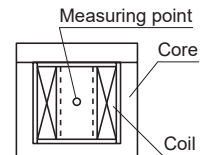

* All specifications are subject to change without notice.

Mn-Zn EPC series Part No.: PC90EPC19-Z

SHAPES AND DIMENSIONS

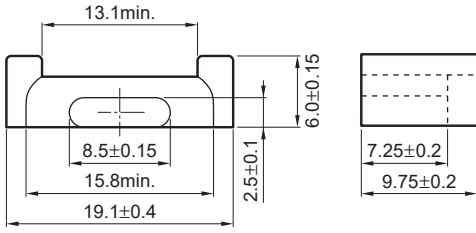

Dimensions in mm

| Effective parameter | | | | | | | | Electrical characteristics | |
|------------------------------|--------------------------------------|--------------------------------------|-----------------------------|---|--|---|---------|---------------------------------------|-------------------------------------|
| Core factor | Effective magnetic path length l_e | Effective cross-sectional area A_e | Effective core volume V_e | Cross-sectional center pole area A_{cp} | Minimum cross-sectional center pole area $A_{cp \text{ min.}}$ | Cross-sectional winding area of core A_{cw} | Weight | AL-value * | Core loss |
| C_1 (mm ⁻¹) | (mm) | (mm ²) | (mm ³) | (mm ²) | (mm ²) | (mm ²) | (g/set) | (nH/N ²) 1kHz 0.5mA | (W)max. 100kHz 200mT 100°C |
| 2.03 | 46.1 | 22.7 | 1050 | 19.9 | 18.7 | 54.4 | 5.3 | 940±25% | 0.5 |

*Coil : ø0.2 2UEW 100Ts

○ Calculated output power (forward converter mode): 28W

NI limit vs. AL-value (Typ.)

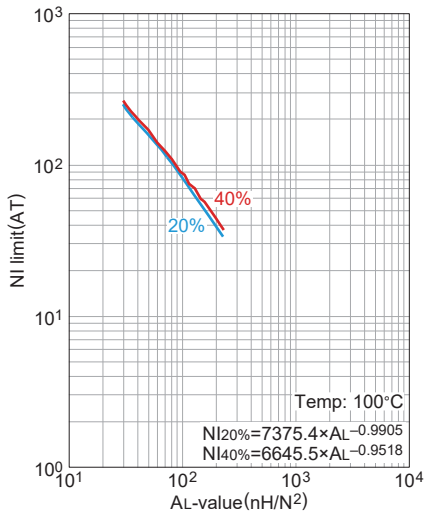

The 20% and 40% graph shows when a 20% and 40% drop from the initial AL-value has been made due to the DC superimposition.

AL-value vs. Air gap length (Typ.)

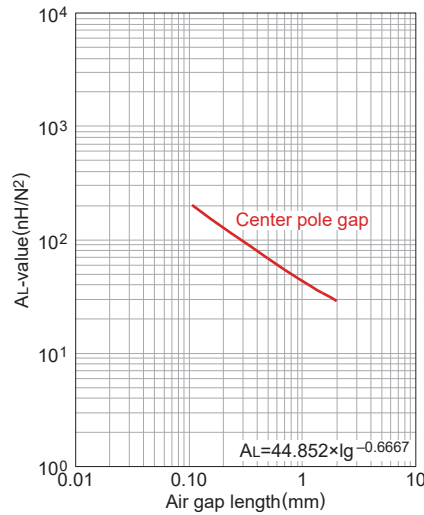

Measuring conditions
 • Coil : ø0.2 2UEW 100Ts
 • Frequency : 1kHz
 • Current level : 0.5mA
 • Ambient temperature : 25°C

Temperature rise vs. Total loss (Typ.)

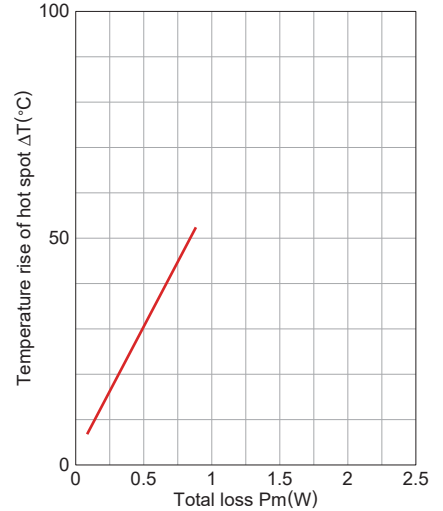

Measuring conditions
 • Room space: approx. 400x300x 300cm
 • Ambient temperature : 25°C
 • Humidity : 45%(%)RH.

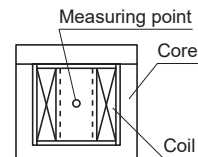

• All specifications are subject to change without notice.

Mn-Zn EPC series Part No.: PC95EPC19-Z

SHAPES AND DIMENSIONS

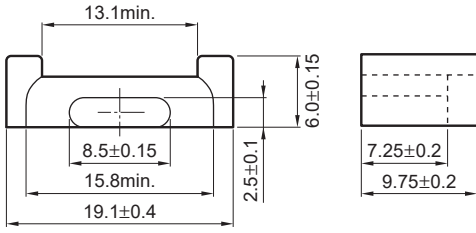

Dimensions in mm

| Effective parameter | | | | | | | | Electrical characteristics | | | |
|---------------------------|---|---|--|--|---|--|----------------|---------------------------------|-------------------|------|-------|
| Core factor | Effective magnetic path length l_e (mm) | Effective cross-sectional area A_e (mm ²) | Effective core volume V_e (mm ³) | Cross-sectional center pole area A_{cp} (mm ²) | Minimum cross-sectional center pole area $A_{cp \text{ min.}}$ (mm ²) | Cross-sectional winding area of core A_{cw} (mm ²) | Weight (g/set) | AL-value * (nH/N ²) | Core loss (W)max. | | |
| C_1 (mm ⁻¹) | | | | | | | | 1kHz 0.5mA | 25°C | 80°C | 120°C |
| 2.03 | 46.1 | 22.7 | 1050 | 19.9 | 18.7 | 54.4 | 5.3 | 1400±25% | 0.5 | 0.4 | 0.5 |

*Coil : ø0.2 2UEW 100Ts

○ Calculated output power (forward converter mode): 28.7W

NI limit vs. AL-value (Typ.)

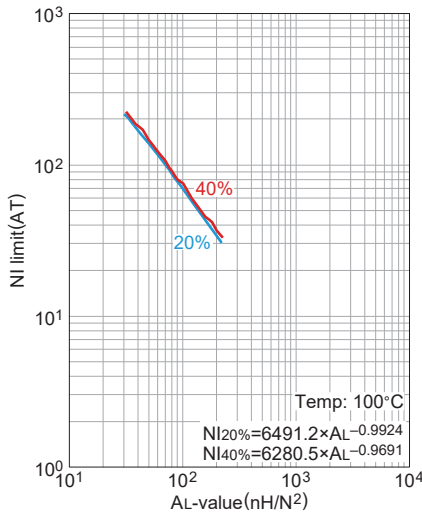

The 20% and 40% graph shows when a 20% and 40% drop from the initial AL-value has been made due to the DC superimposition.

AL-value vs. Air gap length (Typ.)

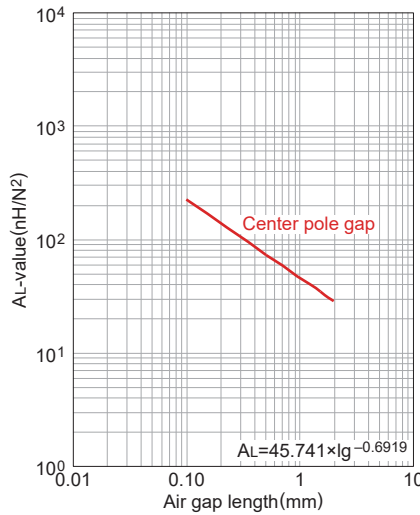

Measuring conditions

- Coil : ø0.2 2UEW 100Ts
- Frequency : 1kHz
- Current level : 0.5mA
- Ambient temperature : 25°C

Temperature rise vs. Total loss (Typ.)

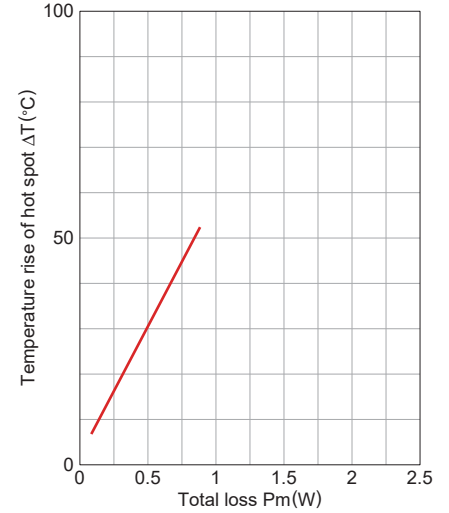

Measuring conditions

- Room space: approx. 400x300x 300cm
- Ambient temperature : 25°C
- Humidity: 45(%RH).

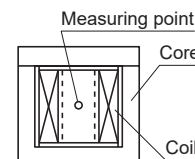

• All specifications are subject to change without notice.

Mn-Zn EPC series **Part No.: PC47EPC25-Z**

SHAPES AND DIMENSIONS

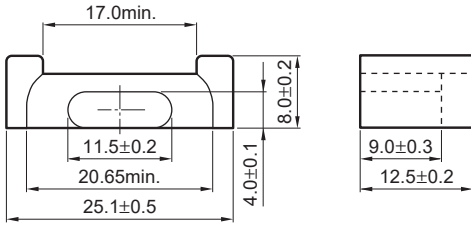

Dimensions in mm

| Effective parameter | | | | | | | | Electrical characteristics | |
|------------------------|---|---|--|--|---|--|----------------|---------------------------------|--------------------------------------|
| Core factor | Effective magnetic path length l_e (mm) | Effective cross-sectional area A_e (mm ²) | Effective core volume V_e (mm ³) | Cross-sectional center pole area A_{cp} (mm ²) | Minimum cross-sectional center pole area $A_{cp \text{ min.}}$ (mm ²) | Cross-sectional winding area of core A_{cw} (mm ²) | Weight (g/set) | AL-value * (nH/N ²) | Core loss (W)max. 100kHz 200mT 100°C |
| C1 (mm ⁻¹) | 56.3 | 40.4 | 2280 | 42.6 | 40.6 | 85.5 | 13 | 1560±25% | 1.08 |

* Coil : ø0.2 2UEW 100Ts

○ Calculated output power (forward converter mode): 71.6W (100kHz)

NI limit vs. AL-value (Typ.)

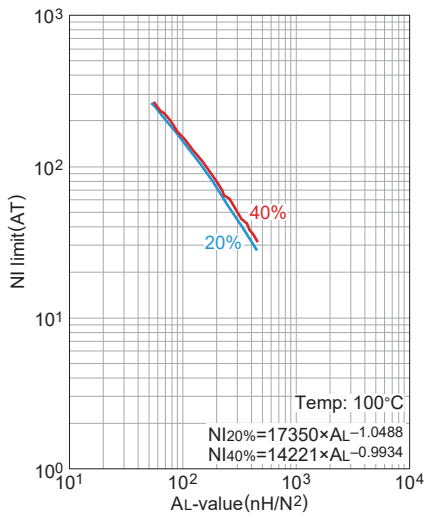

The 20% and 40% graph shows when a 20% and 40% drop from the initial AL-value has been made due to the DC superimposition.

AL-value vs. Air gap length (Typ.)

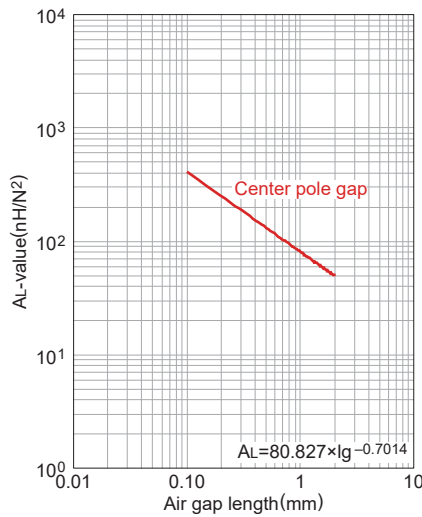

Measuring conditions
 • Coil : ø0.2 2UEW 100Ts
 • Frequency : 1kHz
 • Current level : 0.5mA
 • Ambient temperature : 25°C

Temperature rise vs. Total loss (Typ.)

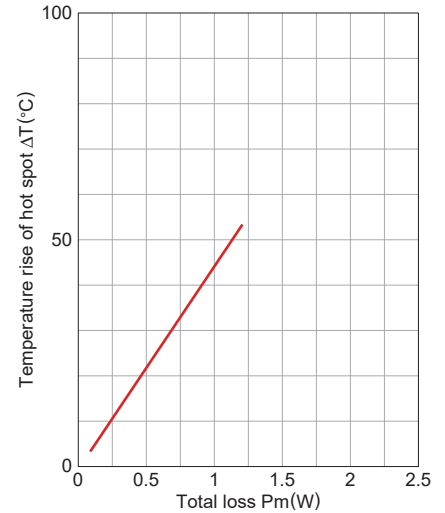

Measuring conditions
 • Room space: approx. 400x300x 300cm
 • Ambient temperature : 25°C
 • Humidity : 45%(%)RH.

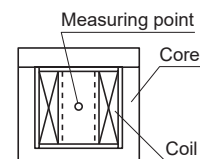

• All specifications are subject to change without notice.

Mn-Zn EPC series Part No.: PC90EPC25-Z

SHAPES AND DIMENSIONS

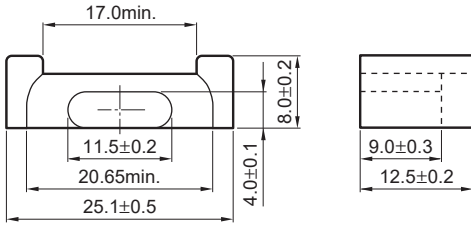

Dimensions in mm

| Effective parameter | | | | | | | | Electrical characteristics | |
|------------------------|---|---|--|--|---|--|----------------|---------------------------------|--------------------------------------|
| Core factor | Effective magnetic path length l_e (mm) | Effective cross-sectional area A_e (mm ²) | Effective core volume V_e (mm ³) | Cross-sectional center pole area A_{cp} (mm ²) | Minimum cross-sectional center pole area $A_{cp \text{ min.}}$ (mm ²) | Cross-sectional winding area of core A_{cw} (mm ²) | Weight (g/set) | AL-value * (nH/N ²) | Core loss (W)max. 100kHz 200mT 100°C |
| C1 (mm ⁻¹) | 56.3 | 40.4 | 2280 | 42.6 | 40.6 | 85.5 | 13 | 1400±25% | 1.4 |

* Coil : ø0.2 2UEW 100Ts

○ Calculated output power (forward converter mode): 64W

NI limit vs. AL-value (Typ.)

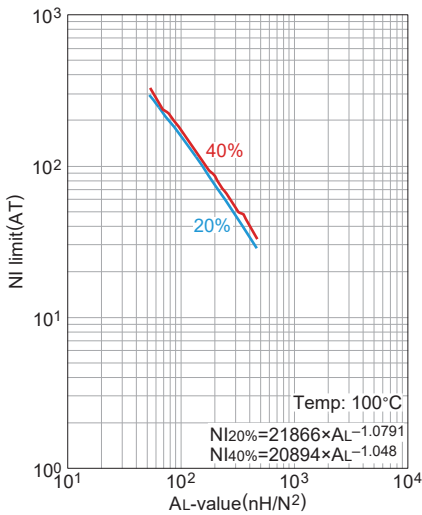

The 20% and 40% graph shows when a 20% and 40% drop from the initial AL-value has been made due to the DC superimposition.

AL-value vs. Air gap length (Typ.)

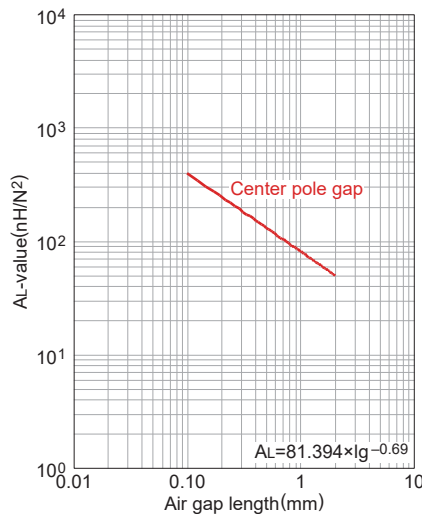

Measuring conditions
 • Coil : ø0.2 2UEW 100Ts
 • Frequency : 1kHz
 • Current level : 0.5mA
 • Ambient temperature : 25°C

Temperature rise vs. Total loss (Typ.)

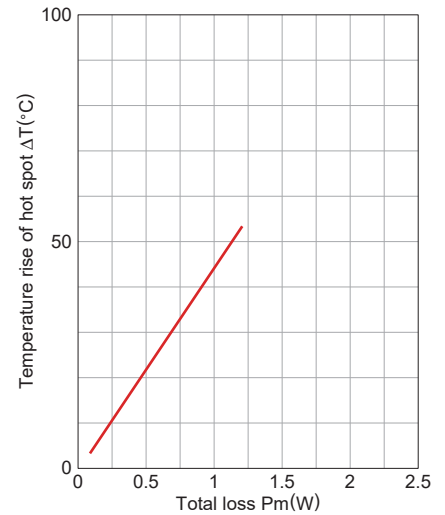

Measuring conditions
 • Room space: approx. 400x300x 300cm
 • Ambient temperature : 25°C
 • Humidity: 45%(%)RH.

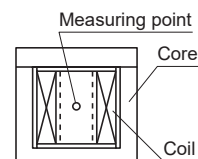

• All specifications are subject to change without notice.

Mn-Zn EPC series **Part No.: PC95EPC25-Z**

SHAPES AND DIMENSIONS

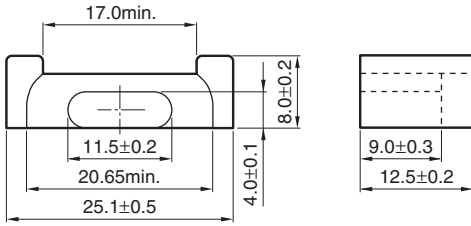

Dimensions in mm

| Effective parameter | | | | | | | | Electrical characteristics | | | |
|---------------------------|---|---|--|--|---|--|----------------|---------------------------------|-------------------|------|-------|
| Core factor | Effective magnetic path length l_e (mm) | Effective cross-sectional area A_e (mm ²) | Effective core volume V_e (mm ³) | Cross-sectional center pole area A_{cp} (mm ²) | Minimum cross-sectional center pole area $A_{cp \text{ min.}}$ (mm ²) | Cross-sectional winding area of core A_{cw} (mm ²) | Weight (g/set) | AL-value * (nH/N ²) | Core loss (W)max. | | |
| C_1 (mm ⁻¹) | | | | | | | | 1kHz 0.5mA | 25°C | 80°C | 120°C |
| 1.40 | 56.3 | 40.4 | 2280 | 42.6 | 40.6 | 85.5 | 13 | 2200±25% | 1.4 | 1.2 | 1.4 |

* Coil : ø0.2 2UEW 100Ts

○ Calculated output power (forward converter mode): 66.9W

NI limit vs. AL-value (Typ.)

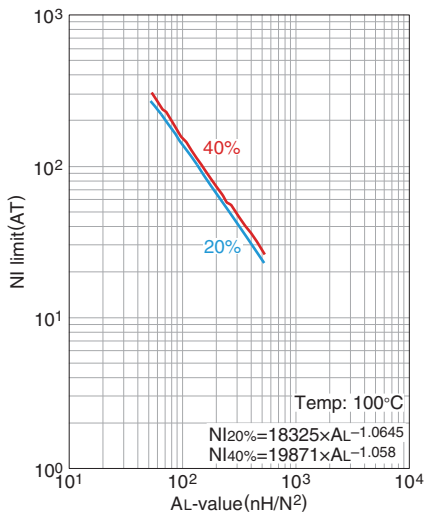

The 20% and 40% graph shows when a 20% and 40% drop from the initial AL-value has been made due to the DC superimposition.

AL-value vs. Air gap length (Typ.)

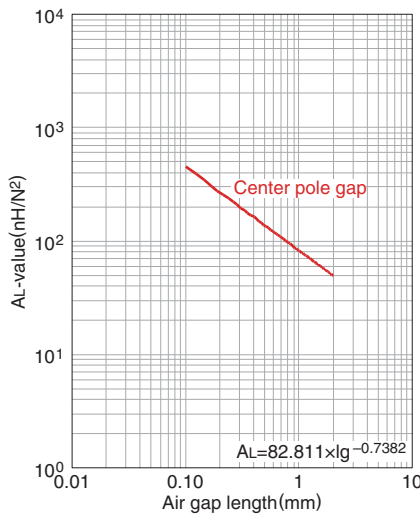

Measuring conditions
 • Coil : ø0.2 2UEW 100Ts
 • Frequency : 1kHz
 • Current level : 0.5mA
 • Ambient temperature : 25°C

Temperature rise vs. Total loss (Typ.)

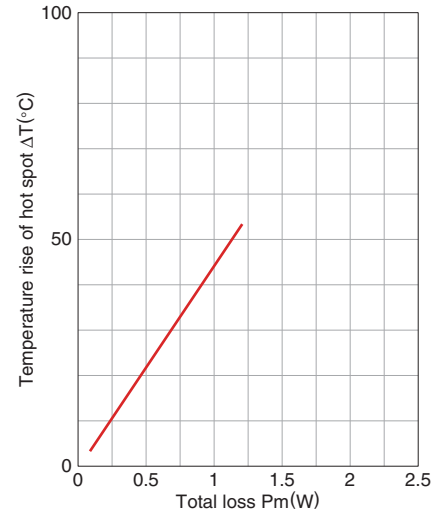

Measuring conditions
 • Room space: approx. 400x300x 300cm
 • Ambient temperature : 25°C
 • Humidity: 45%(%)RH.

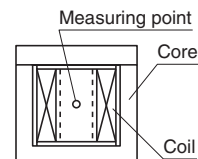

• All specifications are subject to change without notice.

Mn-Zn EPC series Part No.: PC47EPC25B-Z

SHAPES AND DIMENSIONS

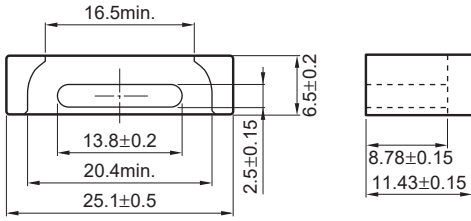

Dimensions in mm

| Effective parameter | | | | | | | | Electrical characteristics | |
|---------------------|---|---|--|--|---|--|----------------|---------------------------------|--------------------------------------|
| Core factor | Effective magnetic path length l_e (mm) | Effective cross-sectional area A_e (mm ²) | Effective core volume V_e (mm ³) | Cross-sectional center pole area A_{cp} (mm ²) | Minimum cross-sectional center pole area $A_{cp \text{ min.}}$ (mm ²) | Cross-sectional winding area of core A_{cw} (mm ²) | Weight (g/set) | AL-value * (nH/N ²) | Core loss (W)max. 100kHz 200mT 100°C |
| 1.39 | 46.2 | 33.3 | 1540 | 32.4 | 30.3 | 62.1 | 11 | 1560±25% | 0.64 |

* Coil : $\phi 0.23$ 2UEW 100Ts

○ Calculated output power (forward converter mode): 50.3W (100kHz)

NI limit vs. AL-value (Typ.)

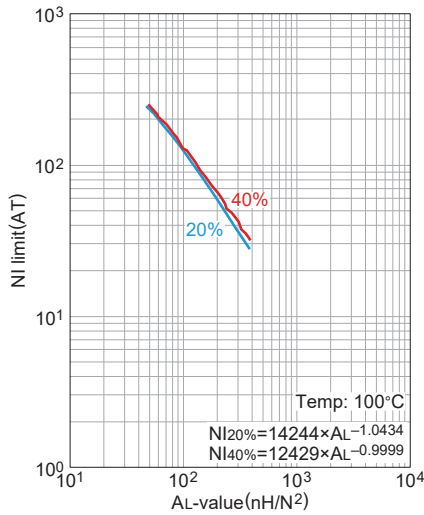

The 20% and 40% graph shows when a 20% and 40% drop from the initial AL-value has been made due to the DC superimposition.

AL-value vs. Air gap length (Typ.)

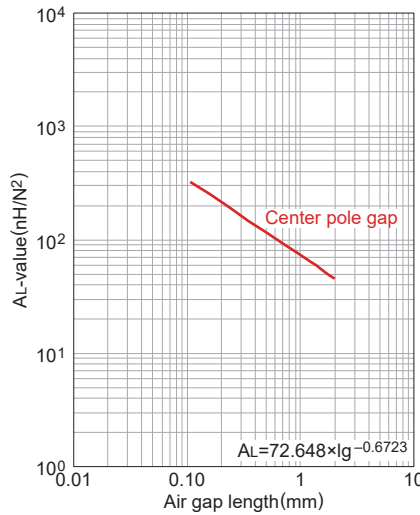

Measuring conditions
 • Coil : $\phi 0.23$ 2UEW 100Ts
 • Frequency : 1kHz
 • Current level : 0.5mA
 • Ambient temperature : 25°C

Temperature rise vs. Total loss (Typ.)

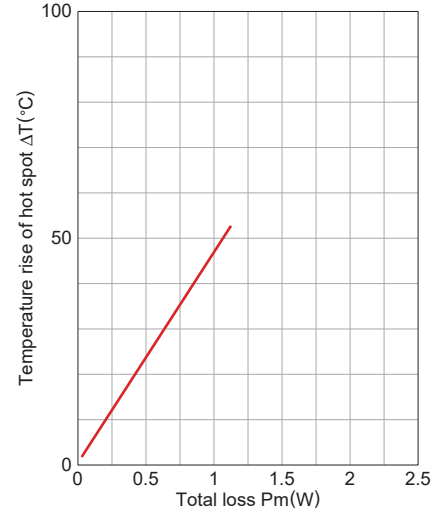

Measuring conditions
 • Room space: approx. 400x300x 300cm
 • Ambient temperature : 25°C
 • Humidity : 45%(%)RH.

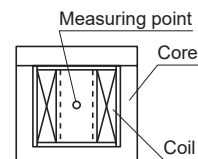

• All specifications are subject to change without notice.

Mn-Zn EPC series Part No.: PC90EPC25B-Z

SHAPES AND DIMENSIONS

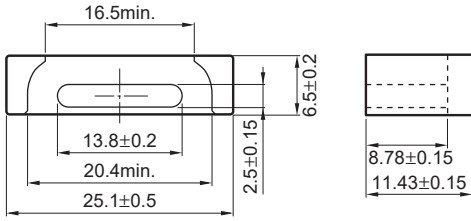

Dimensions in mm

| Effective parameter | | | | | | | | Electrical characteristics | |
|------------------------|---|---|--|--|---|--|----------------|---------------------------------|--------------------------------------|
| Core factor | Effective magnetic path length l_e (mm) | Effective cross-sectional area A_e (mm ²) | Effective core volume V_e (mm ³) | Cross-sectional center pole area A_{cp} (mm ²) | Minimum cross-sectional center pole area $A_{cp \text{ min.}}$ (mm ²) | Cross-sectional winding area of core A_{cw} (mm ²) | Weight (g/set) | AL-value * (nH/N ²) | Core loss (W)max. 100kHz 200mT 100°C |
| C1 (mm ⁻¹) | 46.2 | 33.3 | 1540 | 32.4 | 30.3 | 62.1 | 11 | 1400±25% | 0.8 |

* Coil : ø0.23 2UEW 100Ts

○ Calculated output power (forward converter mode): 46W

NI limit vs. AL-value (Typ.)

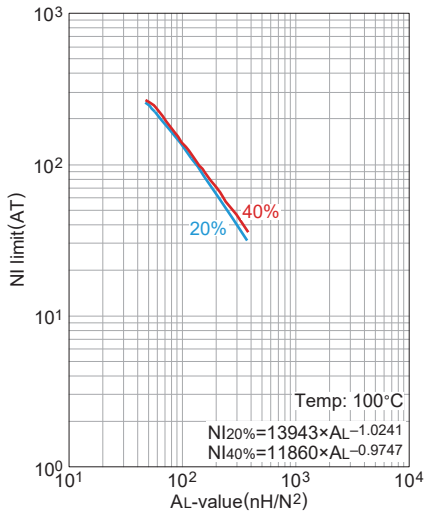

The 20% and 40% graph shows when a 20% and 40% drop from the initial AL-value has been made due to the DC superimposition.

AL-value vs. Air gap length (Typ.)

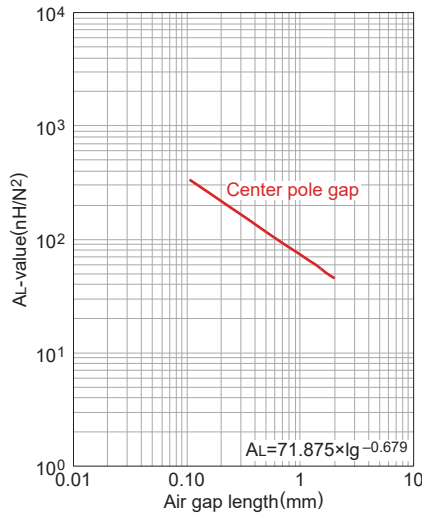

Measuring conditions

- Coil : ø0.23 2UEW 100Ts
- Frequency : 1kHz
- Current level : 0.5mA
- Ambient temperature : 25°C

Temperature rise vs. Total loss (Typ.)

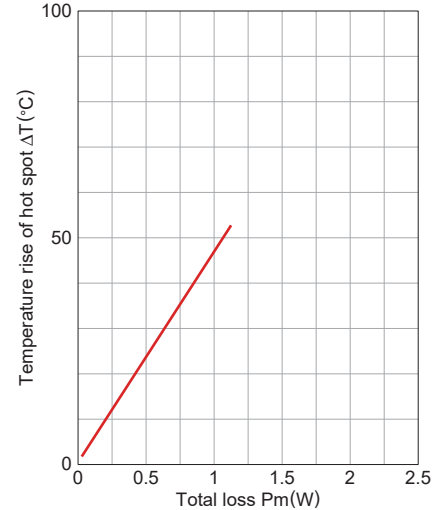

Measuring conditions

- Room space: approx. 400x300x 300cm
- Ambient temperature : 25°C
- Humidity: 45(%RH).

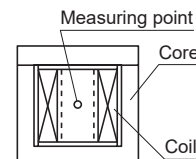

• All specifications are subject to change without notice.

Mn-Zn EPC series **Part No.: PC95EPC25B-Z**

SHAPES AND DIMENSIONS

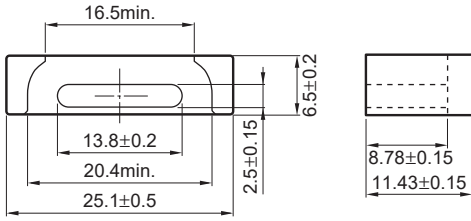

Dimensions in mm

| Effective parameter | | | | | | | | Electrical characteristics | | | |
|------------------------------------|---|---|--|--|---|--|----------------|---------------------------------|-------------------|------|-------|
| Core factor | Effective magnetic path length l_e (mm) | Effective cross-sectional area A_e (mm ²) | Effective core volume V_e (mm ³) | Cross-sectional center pole area A_{cp} (mm ²) | Minimum cross-sectional center pole area $A_{cp \text{ min.}}$ (mm ²) | Cross-sectional winding area of core A_{cw} (mm ²) | Weight (g/set) | AL-value * (nH/N ²) | Core loss (W)max. | | |
| C ₁ (mm ⁻¹) | | | | | | | | 1kHz 0.5mA | 25°C | 80°C | 120°C |
| 1.39 | 46.2 | 33.3 | 1540 | 32.4 | 30.3 | 62.1 | 11 | 2200±25% | 0.8 | 0.65 | 0.8 |

* Coil : ø0.23 2UEW 100Ts

○ Calculated output power (forward converter mode): 47.6W

NI limit vs. AL-value (Typ.)

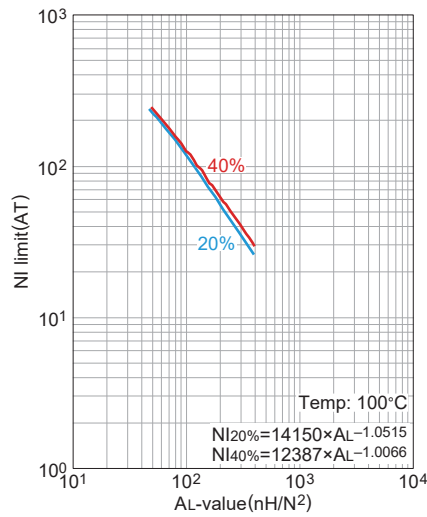

The 20% and 40% graph shows when a 20% and 40% drop from the initial AL-value has been made due to the DC superimposition.

AL-value vs. Air gap length (Typ.)

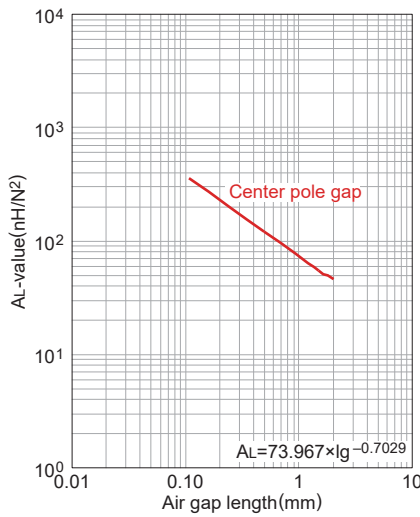

Measuring conditions

- Coil : ø0.23 2UEW 100Ts
- Frequency : 1kHz
- Current level : 0.5mA
- Ambient temperature : 25°C

Temperature rise vs. Total loss (Typ.)

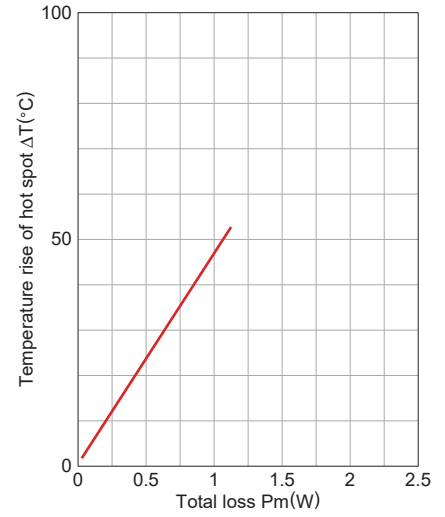

Measuring conditions

- Room space: approx. 400x300x 300cm
- Ambient temperature : 25°C
- Humidity: 45(%RH).

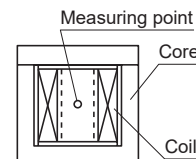

• All specifications are subject to change without notice.

Mn-Zn EPC series Part No.: PC47EPC27-Z

SHAPES AND DIMENSIONS

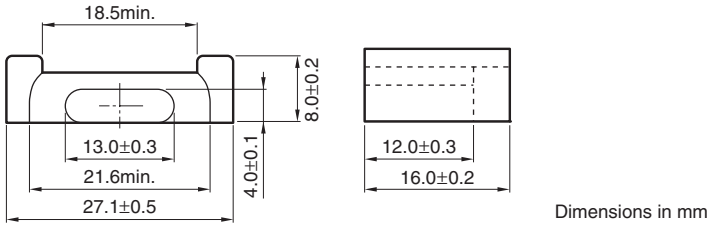

| Effective parameter | | | | | | | | Electrical characteristics | |
|---------------------|---|---|--|--|---|--|----------------|---------------------------------|--------------------------------------|
| Core factor | Effective magnetic path length l_e (mm) | Effective cross-sectional area A_e (mm ²) | Effective core volume V_e (mm ³) | Cross-sectional center pole area A_{cp} (mm ²) | Minimum cross-sectional center pole area $A_{cp \text{ min.}}$ (mm ²) | Cross-sectional winding area of core A_{cw} (mm ²) | Weight (g/set) | AL-value * (nH/N ²) | Core loss (W)max. 100kHz 200mT 100°C |
| 1.43 | 69.4 | 48.6 | 3370 | 48.6 | 46.5 | 108 | 18 | 1540±25% | 1.53 |

* Coil : $\phi 0.3$ 2UEW 100Ts
 ○ Calculated output power (forward converter mode): 88.7W (100kHz)

NI limit vs. AL-value (Typ.)

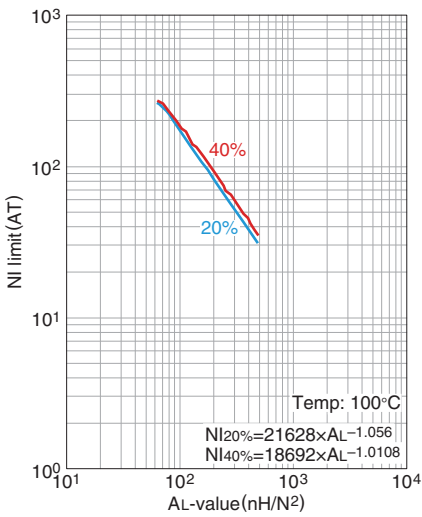

The 20% and 40% graph shows when a 20% and 40% drop from the initial AL-value has been made due to the DC superimposition.

AL-value vs. Air gap length (Typ.)

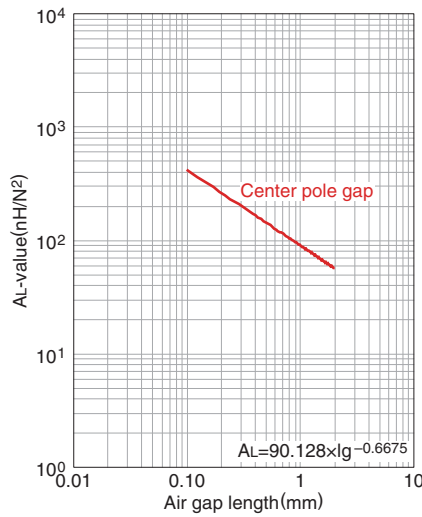

Measuring conditions
 • Coil : $\phi 0.3$ 2UEW 100Ts
 • Frequency : 1kHz
 • Current level : 0.5mA
 • Ambient temperature : 25°C

Temperature rise vs. Total loss (Typ.)

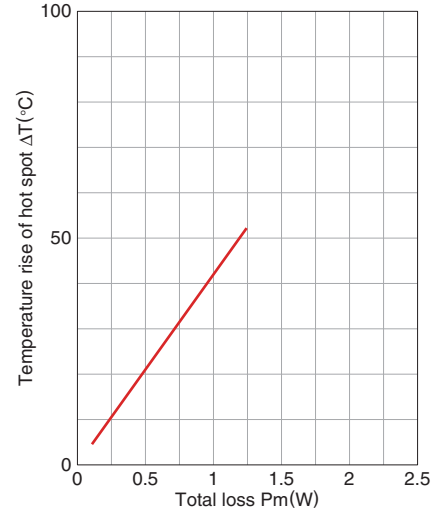

Measuring conditions
 • Room space: approx. 400x300x 300cm
 • Ambient temperature : 25°C
 • Humidity : 45(%RH).

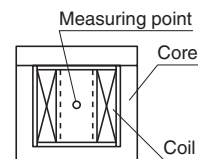

• All specifications are subject to change without notice.

Mn-Zn EPC series Part No.: PC90EPC27-Z

SHAPES AND DIMENSIONS

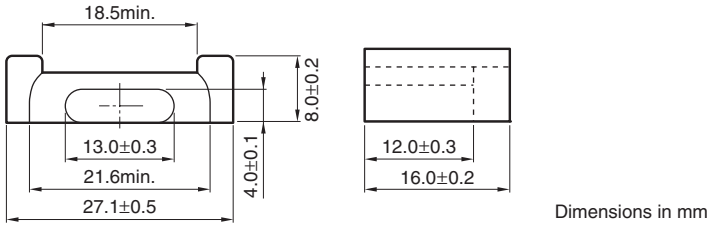

| Effective parameter | | | | | | | | Electrical characteristics | |
|------------------------------------|---|---|--|--|---|--|----------------|---------------------------------|--------------------------------------|
| Core factor | Effective magnetic path length l_e (mm) | Effective cross-sectional area A_e (mm ²) | Effective core volume V_e (mm ³) | Cross-sectional center pole area A_{cp} (mm ²) | Minimum cross-sectional center pole area $A_{cp \text{ min.}}$ (mm ²) | Cross-sectional winding area of core A_{cw} (mm ²) | Weight (g/set) | AL-value * (nH/N ²) | Core loss (W)max. 100kHz 200mT 100°C |
| C ₁ (mm ⁻¹) | | | | | | | | 1400±25% | 2.0 |
| 1.43 | 69.4 | 48.6 | 3370 | 48.6 | 46.5 | 108 | 18 | | |

* Coil : ø0.3 2UEW 100Ts
 ○ Calculated output power (forward converter mode): 80.5W

NI limit vs. AL-value (Typ.)

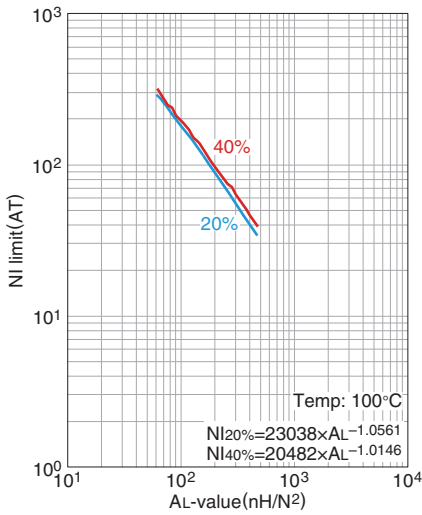

The 20% and 40% graph shows when a 20% and 40% drop from the initial AL-value has been made due to the DC superimposition.

AL-value vs. Air gap length (Typ.)

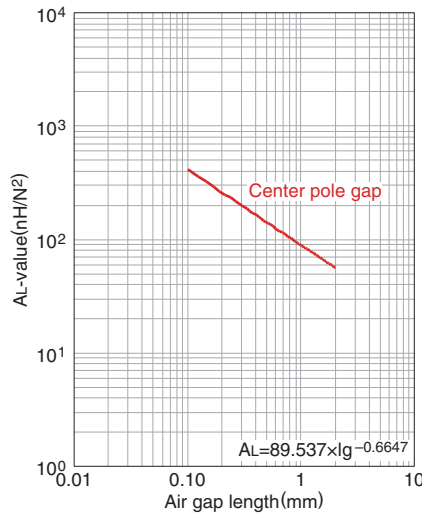

Measuring conditions
 • Coil : ø0.3 2UEW 100Ts
 • Frequency : 1kHz
 • Current level : 0.5mA
 • Ambient temperature : 25°C

Temperature rise vs. Total loss (Typ.)

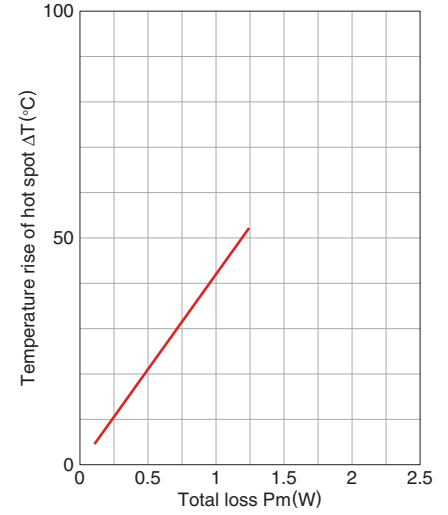

Measuring conditions
 • Room space: approx. 400x300x 300cm
 • Ambient temperature : 25°C
 • Humidity : 45(%)RH.

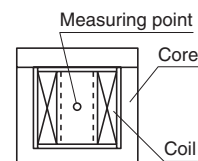

• All specifications are subject to change without notice.

Mn-Zn EPC series Part No.: PC95EPC27-Z

SHAPES AND DIMENSIONS

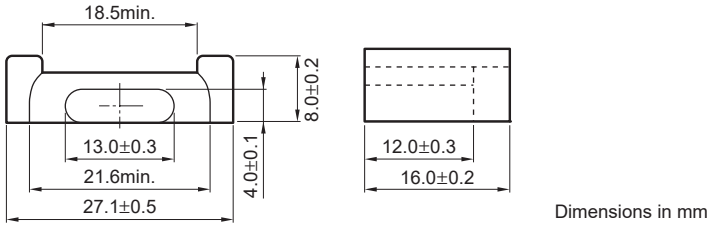

| Effective parameter | | | | | | | | Electrical characteristics | | | |
|---------------------------|---|---|--|--|---|--|----------------|---------------------------------|-------------------|------|-------|
| Core factor | Effective magnetic path length l_e (mm) | Effective cross-sectional area A_e (mm ²) | Effective core volume V_e (mm ³) | Cross-sectional center pole area A_{cp} (mm ²) | Minimum cross-sectional center pole area $A_{cp \text{ min.}}$ (mm ²) | Cross-sectional winding area of core A_{cw} (mm ²) | Weight (g/set) | AL-value * (nH/N ²) | Core loss (W)max. | | |
| C_1 (mm ⁻¹) | | | | | | | | 1kHz 0.5mA | 25°C | 80°C | 120°C |
| 1.43 | 69.4 | 48.6 | 3370 | 48.6 | 46.5 | 108 | 18 | 2200±25% | 2.0 | 1.7 | 2.0 |

* Coil : $\phi 0.3$ 2UEW 100Ts
 ○ Calculated output power (forward converter mode): 84.8W

NI limit vs. AL-value (Typ.)

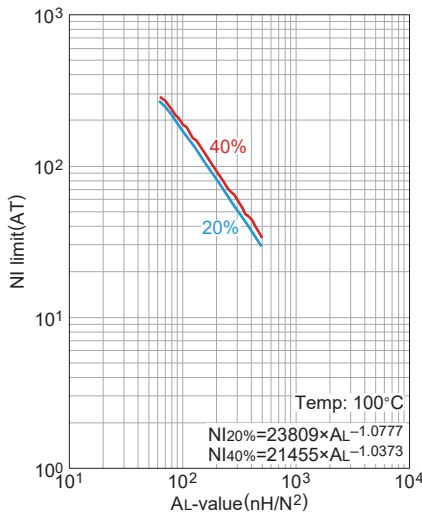

The 20% and 40% graph shows when a 20% and 40% drop from the initial AL-value has been made due to the DC superimposition.

AL-value vs. Air gap length (Typ.)

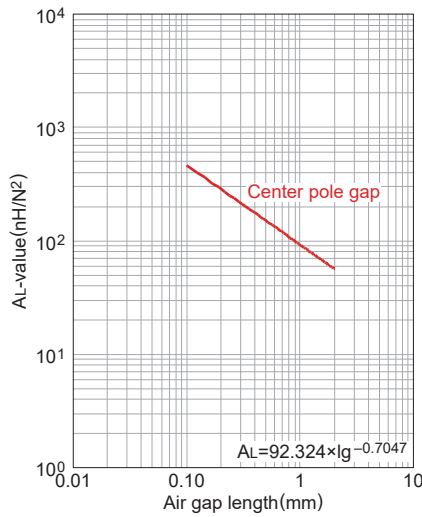

Measuring conditions
 • Coil : $\phi 0.3$ 2UEW 100Ts
 • Frequency : 1kHz
 • Current level : 0.5mA
 • Ambient temperature : 25°C

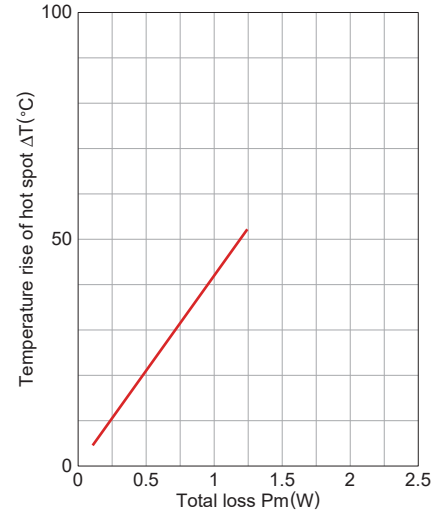

Measuring conditions
 • Room space: approx. 400x300x 300cm
 • Ambient temperature : 25°C
 • Humidity: 45%(%)RH.

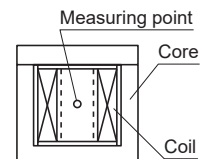

• All specifications are subject to change without notice.

Mn-Zn EPC series **Part No.: PC47EPC30-Z**

SHAPES AND DIMENSIONS

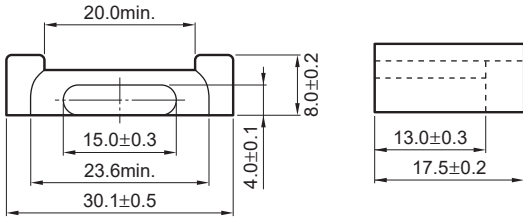

Dimensions in mm

| Effective parameter | | | | | | | | Electrical characteristics | |
|------------------------------|--------------------------------------|--------------------------------------|-----------------------------|---|--|---|---------|---------------------------------------|-------------------------------------|
| Core factor | Effective magnetic path length l_e | Effective cross-sectional area A_e | Effective core volume V_e | Cross-sectional center pole area A_{cp} | Minimum cross-sectional center pole area $A_{cp \text{ min.}}$ | Cross-sectional winding area of core A_{cw} | Weight | AL-value * | Core loss |
| C_1 (mm ⁻¹) | (mm) | (mm ²) | (mm ³) | (mm ²) | (mm ²) | (mm ²) | (g/set) | (nH/N ²) 1kHz 0.5mA | (W)max. 100kHz 200mT 100°C |
| 1.35 | 75.3 | 55.6 | 4190 | 56.6 | 54.3 | 117 | 23 | 1570±25% | 1.99 |

* Coil : ø0.3 2UEW 100Ts

○ Calculated output power (forward converter mode): 95.7W (100kHz)

NI limit vs. AL-value (Typ.)

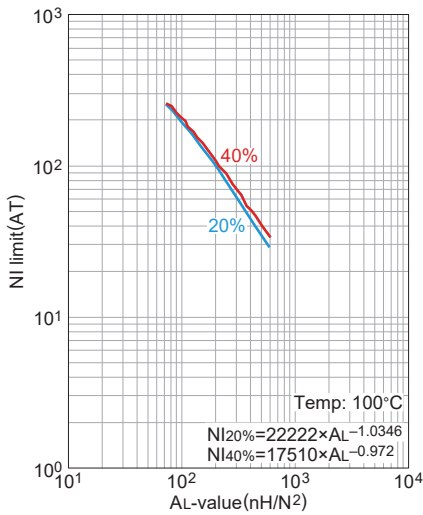

The 20% and 40% graph shows when a 20% and 40% drop from the initial AL-value has been made due to the DC superimposition.

AL-value vs. Air gap length (Typ.)

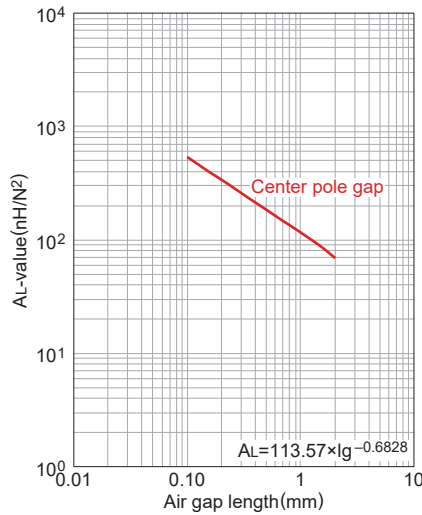

Measuring conditions
 • Coil : ø0.3 2UEW 100Ts
 • Frequency : 1kHz
 • Current level : 0.5mA
 • Ambient temperature : 25°C

Temperature rise vs. Total loss (Typ.)

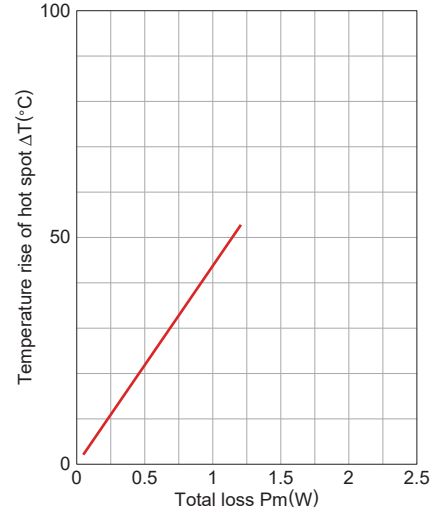

Measuring conditions
 • Room space: approx. 400x300x 300cm
 • Ambient temperature : 25°C
 • Humidity: 45(%)RH.

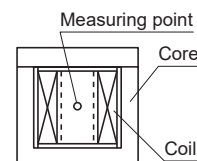

• All specifications are subject to change without notice.

Mn-Zn EPC series Part No.: PC90EPC30-Z

SHAPES AND DIMENSIONS

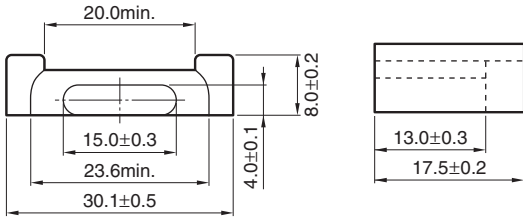

Dimensions in mm

| Effective parameter | | | | | | | | Electrical characteristics | |
|------------------------------------|---|---|--|--|---|--|----------------|---------------------------------|--------------------------------------|
| Core factor | Effective magnetic path length l_e (mm) | Effective cross-sectional area A_e (mm ²) | Effective core volume V_e (mm ³) | Cross-sectional center pole area A_{cp} (mm ²) | Minimum cross-sectional center pole area $A_{cp \text{ min.}}$ (mm ²) | Cross-sectional winding area of core A_{cw} (mm ²) | Weight (g/set) | AL-value * (nH/N ²) | Core loss (W)max. 100kHz 200mT 100°C |
| C ₁ (mm ⁻¹) | 75.3 | 55.6 | 4190 | 56.6 | 54.3 | 117 | 23 | 1700±25% | 2.5 |

* Coil : ø0.3 2UEW 100Ts
 ○ Calculated output power (forward converter mode): 85.5W

NI limit vs. AL-value (Typ.)

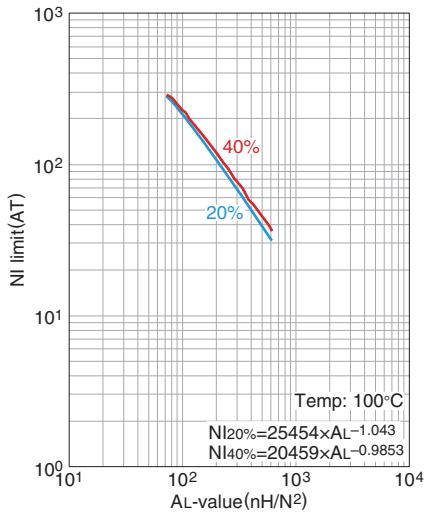

The 20% and 40% graph shows when a 20% and 40% drop from the initial AL-value has been made due to the DC superimposition.

AL-value vs. Air gap length (Typ.)

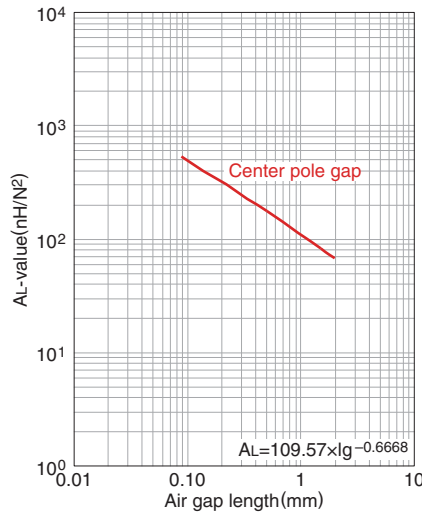

Measuring conditions
 • Coil : ø0.3 2UEW 100Ts
 • Frequency : 1kHz
 • Current level : 0.5mA
 • Ambient temperature : 25°C

Temperature rise vs. Total loss (Typ.)

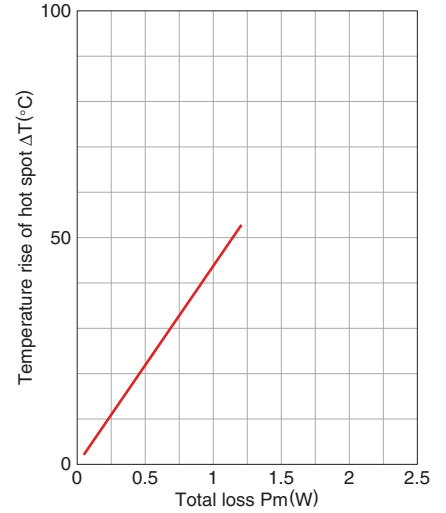

Measuring conditions
 • Room space: approx. 400x300x 300cm
 • Ambient temperature : 25°C
 • Humidity : 45(%)RH.

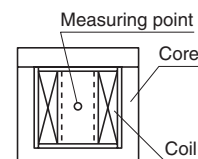

• All specifications are subject to change without notice.

Mn-Zn EPC series **Part No.: PC95EPC30-Z**

SHAPES AND DIMENSIONS

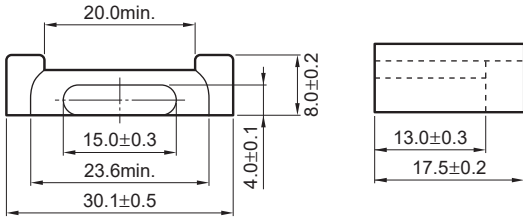

Dimensions in mm

| Effective parameter | | | | | | | | Electrical characteristics | | | |
|---------------------------|--|---|--|--|---|--|----------------|---------------------------------|-------------------|------|-------|
| Core factor | Effective magnetic path length ℓ_e (mm) | Effective cross-sectional area A_e (mm ²) | Effective core volume V_e (mm ³) | Cross-sectional center pole area A_{cp} (mm ²) | Minimum cross-sectional center pole area $A_{cp \text{ min.}}$ (mm ²) | Cross-sectional winding area of core A_{cw} (mm ²) | Weight (g/set) | AL-value * (nH/N ²) | Core loss (W)max. | | |
| C_1 (mm ⁻¹) | | | | | | | | 1kHz 0.5mA | 25°C | 80°C | 120°C |
| 1.35 | 75.3 | 55.6 | 4190 | 56.6 | 54.3 | 117 | 23 | 2300±25% | 2.3 | 2.0 | 2.3 |

* Coil : $\phi 0.3$ 2UEW 100Ts
 ○ Calculated output power (forward converter mode): 90.1W

NI limit vs. AL-value (Typ.)

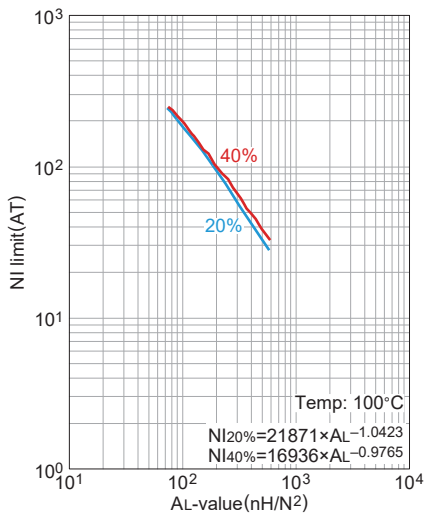

The 20% and 40% graph shows when a 20% and 40% drop from the initial AL-value has been made due to the DC superimposition.

AL-value vs. Air gap length (Typ.)

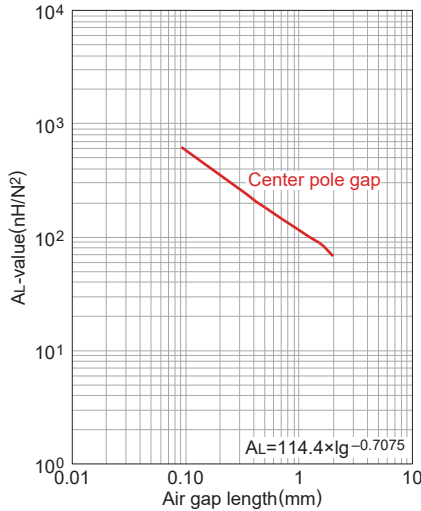

Measuring conditions
 • Coil : $\phi 0.3$ 2UEW 100Ts
 • Frequency : 1kHz
 • Current level : 0.5mA
 • Ambient temperature : 25°C

Temperature rise vs. Total loss (Typ.)

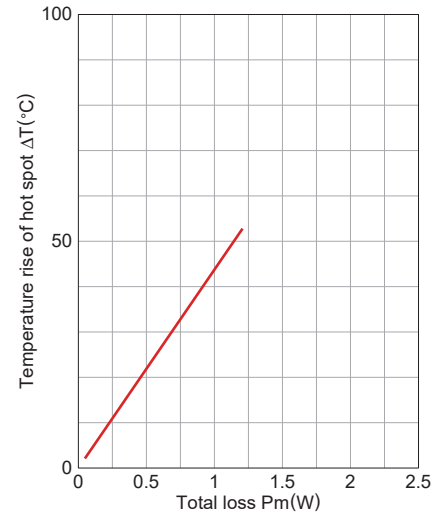

Measuring conditions
 • Room space: approx. 400x300x 300cm
 • Ambient temperature : 25°C
 • Humidity : 45%(%)RH.

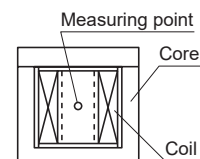

• All specifications are subject to change without notice.

Mn-Zn

Ferrite Cores for Switching Power Supplies

LP series

 **REMINDERS FOR USING THESE PRODUCTS**

Please be sure to read this manual thoroughly before using the products.

The products listed on this catalog are intended for use in general electronic equipment (AV equipment, telecommunications equipment, home appliances, amusement equipment, computer equipment, personal equipment, office equipment, measurement equipment, industrial robots) under a normal operation and use condition.

The products are not designed or warranted to meet the requirements of the applications listed below, whose performance and/or quality require a more stringent level of safety or reliability, or whose failure, malfunction or trouble could cause serious damage to society, person or property.

When using the products for specific purposes, please first make confirmations in areas such as safety, reliability, and quality.

Please understand that we are not in a position to be held responsible for any damage or the like caused by any use exceeding the range or conditions of this specification sheet or by any use in the specific applications.

- | | |
|---|--|
| (1) Aerospace/Aviation equipment | (8) Public information-processing equipment |
| (2) Transportation equipment (electric trains, ships, etc.) | (9) Military equipment |
| (3) Medical equipment | (10) Electric heating apparatus, burning equipment |
| (4) Power-generation control equipment | (11) Disaster prevention/crime prevention equipment |
| (5) Atomic energy-related equipment | (12) Safety equipment |
| (6) Seabed equipment | (13) Other applications that are not considered general-purpose applications |
| (7) Transportation control equipment | |

When using this product in general-purpose standard applications, you are kindly requested to take into consideration securing protection circuit/equipment or providing backup circuits, etc to ensure higher safety.

Ferrite Cores for Switching Power Supplies

Product compatible with RoHS directive
Halogen-free

Overview of the LP Series

FEATURES

- TDK's original shapes.
- The LP Cores have low profiles, and so are useful in situations where mounting is subject to restrictions.

APPLICATION

Transformers and coils for Switched-mode power supplies (High Mounting Density, Low Profile)

PART NUMBER CONSTRUCTION

| | | | | | |
|-----------------|------------------------------|--|---|-------------------------------------|----------------------------|
| PC47 | LP23/8 | Z | - | 1 | 2 |
| Material | Size of LP core | AL-value (Z: without air gap) | | Type | Number of lead slot |
| PC47 | LP23/8 LP22/13 LP32/13 | | | 1 Without air gap 2 With air gap | |

RANGE OF USE AND STORAGE TEMPERATURE

| Temperature range | |
|----------------------------|--------------------------|
| Operating temperature (°C) | Storage temperature (°C) |
| -30 to +105 | -30 to +85 |

- RoHS Directive Compliant Product: See the following for more details related to RoHS Directive compliant products. <http://www.tdk.co.jp/rohs/>
- Halogen-free: Indicates that Cl content is less than 900ppm, Br content is less than 900ppm, and that the total Cl and Br content is less than 1500ppm.

• All specifications are subject to change without notice.

Mn-Zn LP Cores



SHAPES AND DIMENSIONS

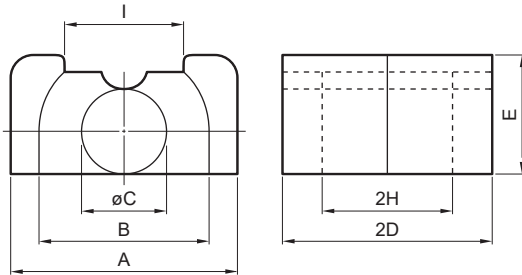

| | | | | | |
|----------|-----------------|----------------------------------|---|-------------------|---------------------|
| LP | LP23/8 | Z | - | 1 | 2 |
| Material | Size of LP core | AL-value (Z: without air gap) | | Type | Number of lead slot |
| | | | | 1 Without air gap | |
| | | | | 2 With air gap | |

| Part No. | Dimensions (mm) | | | | | | |
|-----------------|-----------------|----------|---------|----------|----------|----------|----------|
| | A | B | øC | 2D | E | 2H | I |
| PC47LP23/8Z-12 | 16.5±0.3 | 12.5±0.3 | 5.7±0.1 | 23.4±0.2 | 8.7±0.2 | 17.4±0.2 | 9.0±0.5 |
| PC47LP22/13Z-12 | 25.0±0.4 | 19.0±0.3 | 8.6±0.2 | 22.4±0.2 | 12.9±0.3 | 16.4±0.3 | 13.5±0.5 |
| PC47LP32/13Z-12 | 25.0±0.4 | 19.0±0.3 | 8.6±0.2 | 31.8±0.2 | 12.9±0.3 | 24.1±0.3 | 13.5±0.5 |

| Part No. | Effective parameter | | | | | Electrical characteristics | | |
|-----------------|---|---|---|--|---------------|--|-----------------------------|---|
| | Core factor C _i (mm ⁻¹) | Effective cross-sectional area A _e (mm ²) | Effective magnetic path length ℓ _e (mm) | Effective core volume V _e (mm ³) | Weight (g) | AL-value (nH/N ²) 1kHz 0.5mA 100Ts Without air gap With air gap | | Core loss (W) max. 100kHz 200mT 100°C |
| PC47LP23/8Z-12 | 1.41 | 31.3 | 44.1 | 1380 | 9.6 | 1600±25% | 63±5% 100±7% 250±13% | 0.48 |
| PC47LP22/13Z-12 | 0.721 | 67.9 | 49.0 | 3330 | 21 | 3310±25% | 100±5% 200±7% 400±10% | 1.22 |
| PC47LP32/13Z-12 | 0.909 | 70.3 | 64.0 | 4500 | 30 | 2630±25% | 100±5% 200±7% 400±10% | 1.60 |

• All specifications are subject to change without notice.

Mn-Zn LP series Part No.: PC47LP23/8Z-12

SHAPES AND DIMENSIONS

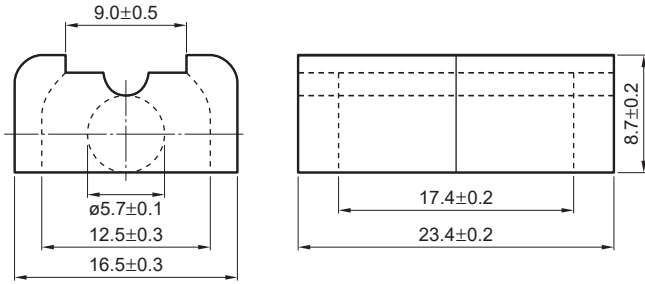

Dimensions in mm

| Effective parameter | | | | | | | | Electrical characteristics | | |
|-------------------------------|--------------------------------------|--------------------------------------|-----------------------------|---|--|---|---------|--------------------------------------|-----------------|-------------------------------------|
| Core factor | Effective magnetic path length l_e | Effective cross-sectional area A_e | Effective core volume V_e | Cross-sectional center pole area A_{cp} | Minimum cross-sectional center pole area $A_{cp \text{ min.}}$ | Cross-sectional winding area of core A_{cw} | Weight | AL-value * | | Core loss |
| C_1 (mm^{-1}) | (mm) | (mm^2) | (mm^3) | (mm^2) | (mm^2) | (mm^2) | (g/set) | (nH/N^2) 1kHz 0.5mA | 100kHz 200mT | (W)max. 100kHz 200mT 100°C |
| 1.41 | 44.1 | 31.3 | 1380 | 25.5 | 24.6 | 59.2 | 9.6 | 1600±25% | 2230 min. | 0.48 |

* Coil : ø0.3 2UEW 100Ts
 ○ Calculated output power (forward converter mode): 54W (100kHz)

NI limit vs. AL-value (Typ.)

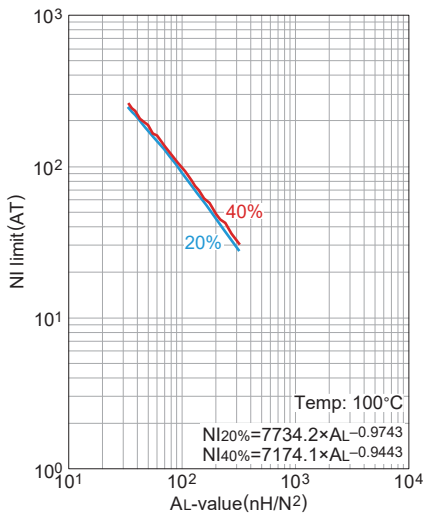

The 20% and 40% graph shows when a 20% and 40% drop from the initial AL-value has been made due to the DC superimposition.

AL-value vs. Air gap length (Typ.)

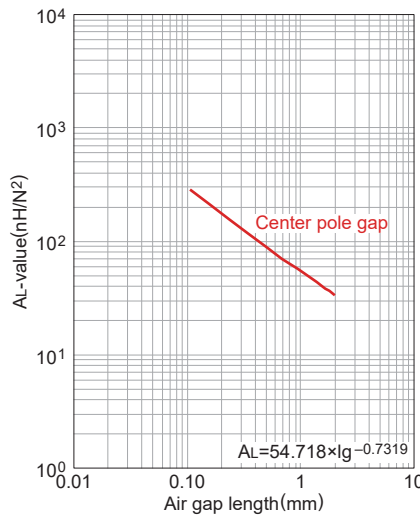

Measuring conditions
 • Coil : ø0.3 2UEW 100Ts
 • Frequency : 1kHz
 • Current level : 0.5mA
 • Ambient temperature : 25°C

Temperature rise vs. Total loss (Typ.)

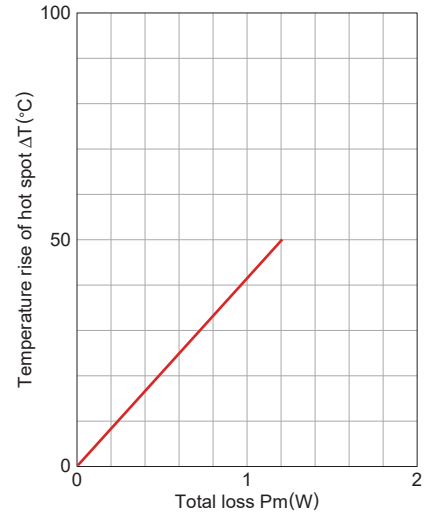

Measuring conditions
 • Room space: approx. 400x300x 300cm
 • Ambient temperature : 25°C
 • Humidity : 45%(%)RH.

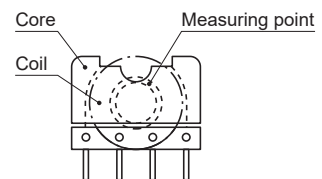

• All specifications are subject to change without notice.

Mn-Zn LP series Part No.: PC47LP22/13Z-12

SHAPES AND DIMENSIONS

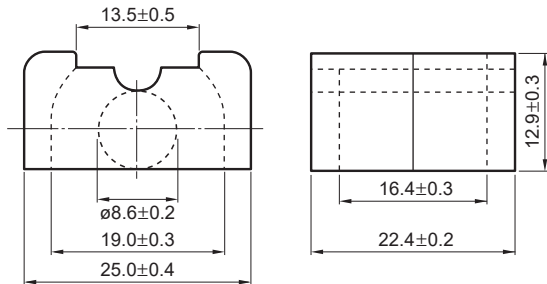

Dimensions in mm

| Effective parameter | | | | | | | | Electrical characteristics | | |
|-------------------------------|--------------------------------------|--------------------------------------|-----------------------------|---|--|---|---------|--------------------------------------|-----------------|-------------------------------------|
| Core factor | Effective magnetic path length l_e | Effective cross-sectional area A_e | Effective core volume V_e | Cross-sectional center pole area A_{cp} | Minimum cross-sectional center pole area $A_{cp \text{ min.}}$ | Cross-sectional winding area of core A_{cw} | Weight | AL-value * | | Core loss |
| C_1 (mm^{-1}) | (mm) | (mm^2) | (mm^3) | (mm^2) | (mm^2) | (mm^2) | (g/set) | (nH/N^2) 1kHz 0.5mA | 100kHz 200mT | (W)max. 100kHz 200mT 100°C |
| 0.721 | 49.0 | 67.9 | 3330 | 58.1 | 55.4 | 84.2 | 21 | 3310±25% | 4700 min. | 1.22 |

* Coil : ø0.35 2UEW 100Ts

○ Calculated output power (forward converter mode): 135W (100kHz)

NI limit vs. AL-value (Typ.)

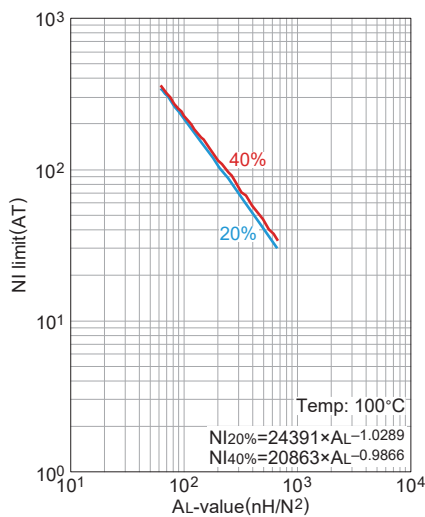

The 20% and 40% graph shows when a 20% and 40% drop from the initial AL-value has been made due to the DC superimposition.

AL-value vs. Air gap length (Typ.)

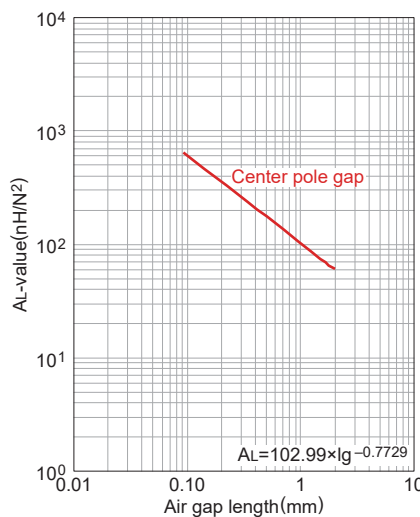

Measuring conditions

- Coil : ø0.35 2UEW 100Ts
- Frequency : 1kHz
- Current level : 0.5mA
- Ambient temperature : 25°C

Temperature rise vs. Total loss (Typ.)

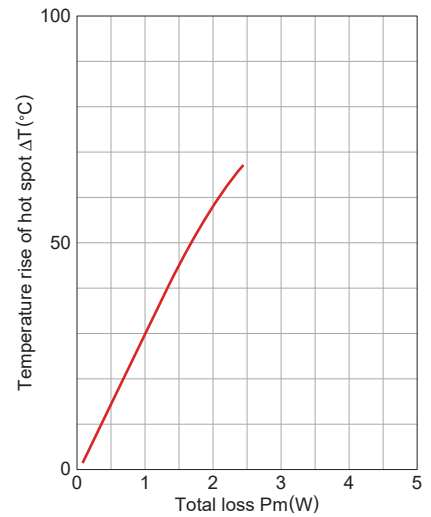

Measuring conditions

- Room space: approx. 400x300x 300cm
- Ambient temperature : 25°C
- Humidity: 45%(%)RH.

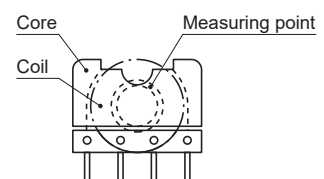

• All specifications are subject to change without notice.

Mn-Zn LP series Part No.: PC47LP32/13Z-12

SHAPES AND DIMENSIONS

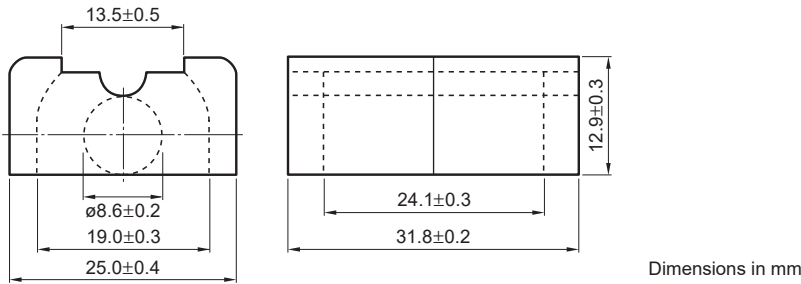

| Effective parameter | | | | | | | | Electrical characteristics | | |
|---------------------------|---|---|--|--|---|--|----------------|----------------------------|-----------------|--------------------------|
| Core factor | Effective magnetic path length l_e (mm) | Effective cross-sectional area A_e (mm ²) | Effective core volume V_e (mm ³) | Cross-sectional center pole area A_{cp} (mm ²) | Minimum cross-sectional center pole area $A_{cp \text{ min.}}$ (mm ²) | Cross-sectional winding area of core A_{cw} (mm ²) | Weight (g/set) | AL-value * | | Core loss (W)max. |
| C_1 (mm ⁻¹) | | | | | | | | 1kHz 0.5mA | 100kHz 200mT | 100kHz 200mT 100°C |
| 0.909 | 64.0 | 70.3 | 4500 | 58.1 | 55.4 | 125.3 | 30 | 2630±25% | 3730 min. | 1.60 |

* Coil : ø0.35 2UEW 100Ts

○ Calculated output power (forward converter mode): 182W (100kHz)

NI limit vs. AL-value (Typ.)

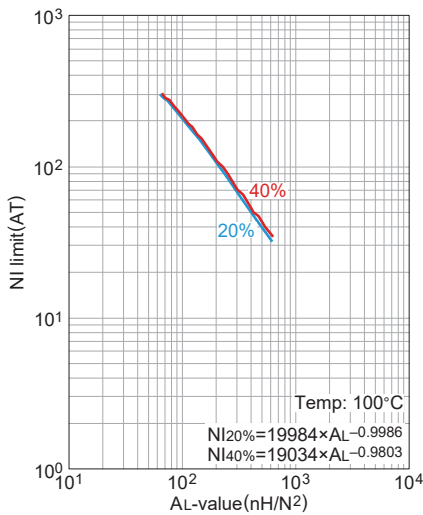

The 20% and 40% graph shows when a 20% and 40% drop from the initial AL-value has been made due to the DC superimposition.

AL-value vs. Air gap length (Typ.)

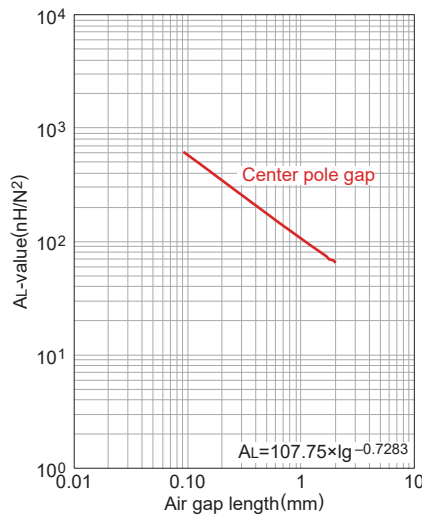

Measuring conditions
 • Coil : ø0.35 2UEW 100Ts
 • Frequency : 1kHz
 • Current level : 0.5mA
 • Ambient temperature : 25°C

Temperature rise vs. Total loss (Typ.)

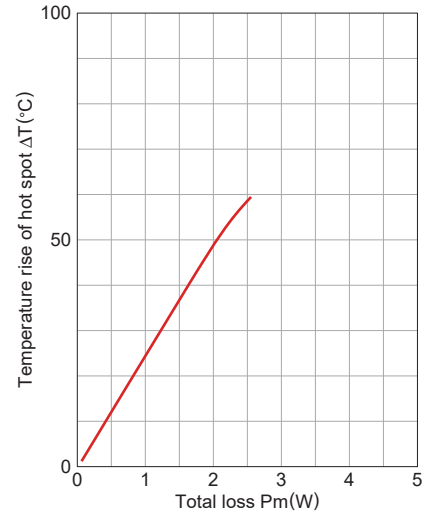

Measuring conditions
 • Room space: approx. 400x300x 300cm
 • Ambient temperature : 25°C
 • Humidity : 45%(%)RH.

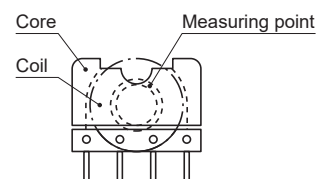

• All specifications are subject to change without notice.

Mn-Zn

Ferrite Cores for Switching Power Supplies

Planar series

EL
ELT
PQI
EIR
ER
EI

 **REMINDERS FOR USING THESE PRODUCTS**

Please be sure to read this manual thoroughly before using the products.

The products listed on this catalog are intended for use in general electronic equipment (AV equipment, telecommunications equipment, home appliances, amusement equipment, computer equipment, personal equipment, office equipment, measurement equipment, industrial robots) under a normal operation and use condition.

The products are not designed or warranted to meet the requirements of the applications listed below, whose performance and/or quality require a more stringent level of safety or reliability, or whose failure, malfunction or trouble could cause serious damage to society, person or property.

When using the products for specific purposes, please first make confirmations in areas such as safety, reliability, and quality.

Please understand that we are not in a position to be held responsible for any damage or the like caused by any use exceeding the range or conditions of this specification sheet or by any use in the specific applications.

- | | |
|---|--|
| (1) Aerospace/Aviation equipment | (8) Public information-processing equipment |
| (2) Transportation equipment (electric trains, ships, etc.) | (9) Military equipment |
| (3) Medical equipment | (10) Electric heating apparatus, burning equipment |
| (4) Power-generation control equipment | (11) Disaster prevention/crime prevention equipment |
| (5) Atomic energy-related equipment | (12) Safety equipment |
| (6) Seabed equipment | (13) Other applications that are not considered general-purpose applications |
| (7) Transportation control equipment | |

When using this product in general-purpose standard applications, you are kindly requested to take into consideration securing protection circuit/equipment or providing backup circuits, etc to ensure higher safety.

Ferrite Cores for Switching Power Supplies

Product compatible with RoHS directive
Halogen-free

Overview of the Planar Series

FEATURES

- Low profile shape suited to PCB mounting
- Available in a range of various shapes
- Available in a pair of E core and I core that easily can be mounted on PCBs
- A wide range of sizes is available from 10mm to 25mm

APPLICATION

Low profile DC/DC converters, transformers and coils for use in planers

PART NUMBER CONSTRUCTION

| | | | | | | | |
|-----------------|-----------------------|--|--------------|-----------|-------------|-------------|-------------|
| PC90 | EL11X4 | - | Z | | | | |
| Material | Size of E core | AL-value (Z: without air gap) | | | | | |
| PC90 PC95 | | | | | | | |
| | EL core | | | | | | |
| | EL11X4 | EL13X4.4 | EL15.5X5.8 | EL18X7.3 | EL20X7.7 | EL22X8 | EL25X8.6 |
| | ELT core | | | | | | |
| | ELT11X3 | ELT11X4 | ELT13X3.4 | ELT13X4.4 | ELT15.5X4.3 | ELT15.5X5.8 | ELT18X5.3 |
| | ELT18X7.3 | ELT20X5.7 | ELT20X7.7 | ELT22X6 | ELT22X8 | ELT25X6.6 | ELT25X8.6 |
| | PQI core | | | | | | |
| | PQI16/7.8Z | PQI20/9Z | PQI26/12Z | | | | |
| | EIR core | | | | | | |
| | EIR14/4.5/9 | EIR18/5/12 | EIR22/5.5/15 | | | | |
| | ER core | | | | | | |
| | ER9.5/5 | ER11/5 | ER14/4.5/9 | ER14.5/6 | ER18/5/12 | ER22/5.5/15 | ER25/5.5/18 |
| | EI core | | | | | | |
| | EI14/5/5 | EI18/6/10 | EI22/8/16 | | | | |

RANGE OF USE AND STORAGE TEMPERATURE

| Temperature range | |
|-------------------------------|-----------------------------|
| Operating temperature (°C) | Storage temperature (°C) |
| -30 to +105 | -30 to +85 |

- RoHS Directive Compliant Product: See the following for more details. <https://product.tdk.com/info/en/environment/rohs/index.html>
- Halogen-free: Indicates that Cl content is less than 900ppm, Br content is less than 900ppm, and that the total Cl and Br content is less than 1500ppm.

⚠ Please be sure to request delivery specifications that provide further details on the features and specifications of the products for proper and safe use. Please note that the contents may change without any prior notice due to reasons such as upgrading.

Mn-Zn EL Cores

SHAPES AND DIMENSIONS

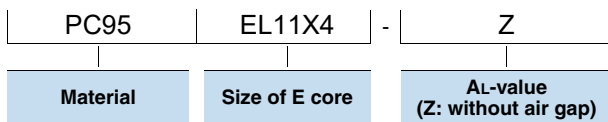
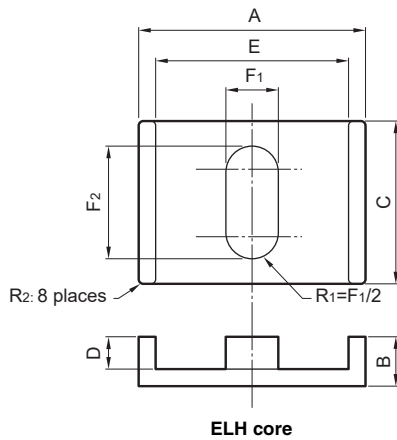

| Part No.(ELH+ELH) | Dimensions (mm) | | | | | | | |
|-------------------|-----------------|-----------|------------|-----------|------------|----------------|----------------|----------------|
| | A | B | C | D | E | F ₁ | F ₂ | R ₂ |
| PC95EL11X4-Z | 11.00±0.20 | 2.01±0.10 | 8.80±0.20 | 1.00±0.10 | 9.17±0.20 | 2.78±0.10 | 6.40±0.15 | 0.30 |
| PC90EL11X4-Z | | | | | | | | |
| PC95EL13X4.4-Z | 13.00±0.25 | 2.19±0.10 | 10.40±0.20 | 1.00±0.10 | 10.83±0.20 | 3.29±0.10 | 7.56±0.15 | 0.30 |
| PC90EL13X4.4-Z | | | | | | | | |
| PC95EL15.5X5.8-Z | 15.50±0.30 | 2.92±0.10 | 12.40±0.25 | 1.50±0.10 | 12.92±0.25 | 3.92±0.10 | 9.01±0.20 | 0.30 |
| PC90EL15.5X5.8-Z | | | | | | | | |
| PC95EL18X7.3-Z | 18.00±0.30 | 3.65±0.10 | 14.40±0.25 | 2.00±0.10 | 15.00±0.30 | 4.55±0.10 | 10.47±0.20 | 0.30 |
| PC90EL18X7.3-Z | | | | | | | | |
| PC95EL20X7.7-Z | 20.00±0.35 | 3.83±0.10 | 16.00±0.30 | 2.00±0.10 | 16.67±0.30 | 5.06±0.15 | 11.63±0.20 | 0.50 |
| PC90EL20X7.7-Z | | | | | | | | |
| PC95EL22X8-Z | 22.00±0.40 | 4.02±0.10 | 17.60±0.30 | 2.00±0.10 | 18.33±0.35 | 5.56±0.15 | 12.79±0.25 | 0.50 |
| PC90EL22X8-Z | | | | | | | | |
| PC95EL25X8.6-Z | 25.00±0.45 | 4.29±0.10 | 20.00±0.35 | 2.00±0.10 | 20.83±0.35 | 6.32±0.15 | 14.54±0.25 | 0.50 |
| PC90EL25X8.6-Z | | | | | | | | |

| Part No.(ELH+ELH) | Effective parameter | | | | | | | Electrical characteristics | |
|-------------------|------------------------------------|--|--|---|---------------------------------------|------------------------------------|-----------|--|------------------|
| | Core factor | Effective magnetic path length ℓ _e (mm) | Effective cross-sectional area A _e (mm ²) | Effective core volume V _e (mm ³) | A _{min} . (mm ²) | A _{cw} (mm ²) | Weigh (g) | AL-value | |
| | C ₁ (mm ⁻¹) | | | | | | | (nH/N ²) 1kHz 0.5mA 100Ts | |
| PC95EL11X4-Z | 0.826 | 13.7 | 16.5 | 226 | 15.9 | 6.39 | 1.3 | 2400±25% | 50±3% |
| PC90EL11X4-Z | | | | | | | | 1950±25% | 80±5% 125±7% |
| PC95EL13X4.4-Z | 0.667 | 15.4 | 23.1 | 357 | 22.4 | 7.54 | 2.0 | 3160±25% | 63±3% |
| PC90EL13X4.4-Z | | | | | | | | 2500±25% | 100±5% 160±7% |
| PC95EL15.5X5.8-Z | 0.597 | 19.6 | 32.9 | 646 | 31.9 | 13.5 | 3.5 | 3680±25% | 63±3% |
| PC90EL15.5X5.8-Z | | | | | | | | 3000±25% | 100±3% 160±5% |
| PC95EL18X7.3-Z | 0.538 | 23.8 | 44.3 | 1050 | 43.0 | 20.9 | 6.0 | 4760±25% | 80±3% |
| PC90EL18X7.3-Z | | | | | | | | 3600±25% | 125±3% 200±5% |
| PC95EL20X7.7-Z | 0.469 | 25.6 | 54.6 | 1400 | 52.9 | 23.2 | 7.8 | 5630±25% | 80±3% |
| PC90EL20X7.7-Z | | | | | | | | 4050±25% | 125±3% 200±5% |
| PC95EL22X8-Z | 0.413 | 27.3 | 66.2 | 1810 | 64.2 | 25.5 | 10 | 6540±25% | 100±3% |
| PC90EL22X8-Z | | | | | | | | 5050±25% | 160±3% 250±5% |
| PC95EL25X8.6-Z | 0.350 | 30.0 | 85.6 | 2570 | 83.0 | 29.0 | 15 | 7540±25% | 100±3% |
| PC90EL25X8.6-Z | | | | | | | | 5700±25% | 160±3% 250±5% |

⚠ Please be sure to request delivery specifications that provide further details on the features and specifications of the products for proper and safe use.
Please note that the contents may change without any prior notice due to reasons such as upgrading.

Mn-Zn Planar series Part No.: PC90EL11X4-Z

SHAPES AND DIMENSIONS

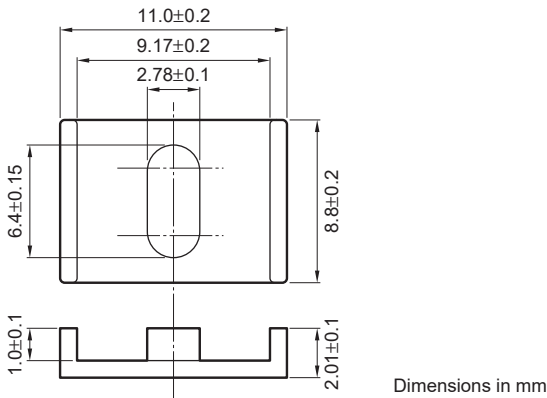

| Effective parameter | | | | | | Electrical characteristics | |
|---------------------------------------|--------------------------------|--------------------------------------|--------------------------------------|--------------------------------------|---------|---------------------------------------|-------------------------------------|
| Core factor | Effective magnetic path length | Effective cross-sectional area | Effective core volume | Cross-sectional winding area of core | Weight | AL-value * | Core loss |
| C ₁ (mm ⁻¹) | ℓ _e (mm) | A _e (mm ²) | V _e (mm ³) | Acw (mm ²) | (g/set) | (nH/N ²) 1kHz 0.5mA | (W)max. 100kHz 200mT 100°C |
| 0.826 | 13.7 | 16.5 | 226 | 6.39 | 1.3 | 1950±25% | 0.2 |

NI limit vs. AL-value (Typ.)

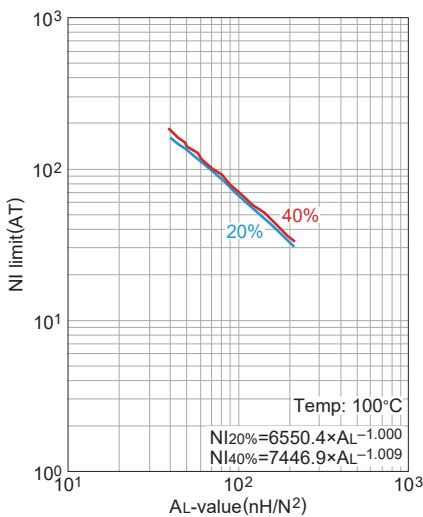

The 20% and 40% graph shows when a 20% and 40% drop from the initial AL-value has been made due to the DC superimposition.

AL-value vs. Air gap length (Typ.)

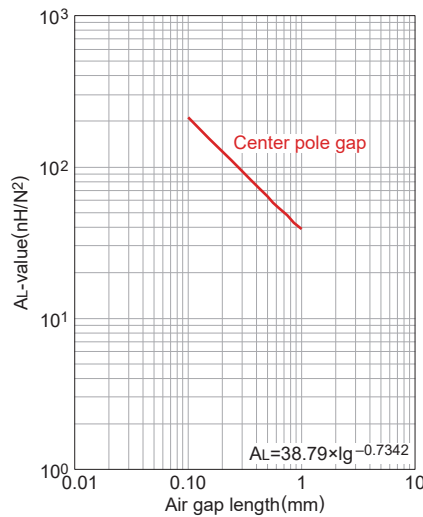

Measuring conditions
 • Coil : ø0.18 2UEW 100Ts
 • Frequency : 1kHz
 • Current level : 0.5mA
 • Ambient temperature : 25°C

⚠ Please be sure to request delivery specifications that provide further details on the features and specifications of the products for proper and safe use. Please note that the contents may change without any prior notice due to reasons such as upgrading.

Mn-Zn Planar series **Part No.: PC95EL11X4-Z**

SHAPES AND DIMENSIONS

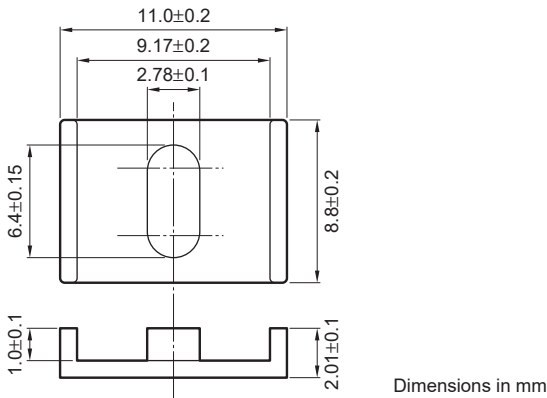

| Effective parameter | | | | | | Electrical characteristics | | | | |
|---------------------------------------|--------------------------------|--------------------------------------|--------------------------------------|---------------------------------------|---------|---------------------------------------|----------------------------|------|------|-------|
| Core factor | Effective magnetic path length | Effective cross-sectional area | Effective core volume | Cross-sectional winding area of core | Weigh | AL-value * | Core loss | | | |
| C ₁ (mm ⁻¹) | ℓ _e (mm) | A _e (mm ²) | V _e (mm ³) | A _{cw} (mm ²) | (g/set) | (nH/N ²) 1kHz 0.5mA | (W)max. 100kHz 200mT | 25°C | 80°C | 120°C |
| 0.826 | 13.7 | 16.5 | 226 | 6.39 | 1.3 | 2400±25% | 0.2 | 0.18 | 0.2 | |

NI limit vs. AL-value (Typ.)

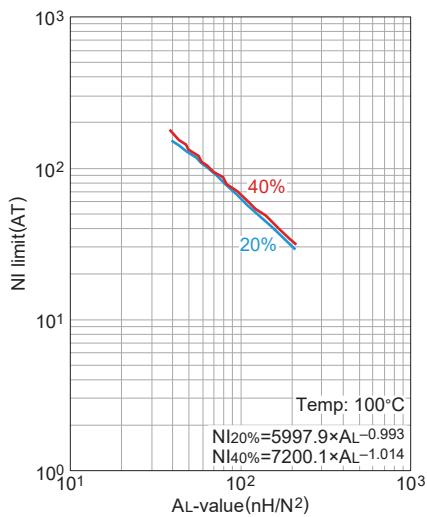

The 20% and 40% graph shows when a 20% and 40% drop from the initial AL-value has been made due to the DC superimposition.

AL-value vs. Air gap length (Typ.)

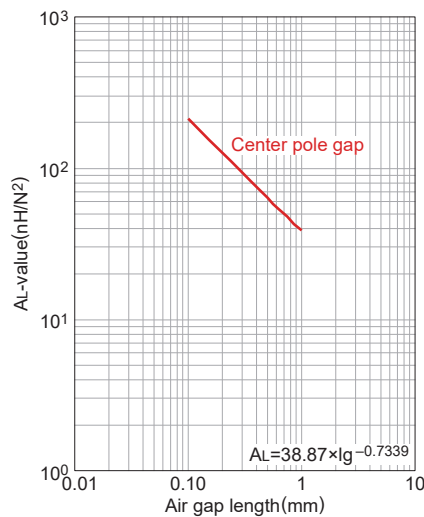

Measuring conditions
 • Coil : ø0.18 2UEW 100Ts
 • Frequency : 1kHz
 • Current level : 0.5mA
 • Ambient temperature : 25°C

⚠ Please be sure to request delivery specifications that provide further details on the features and specifications of the products for proper and safe use. Please note that the contents may change without any prior notice due to reasons such as upgrading.

Mn-Zn Planar series Part No.: PC90EL13X4.4-Z

SHAPES AND DIMENSIONS

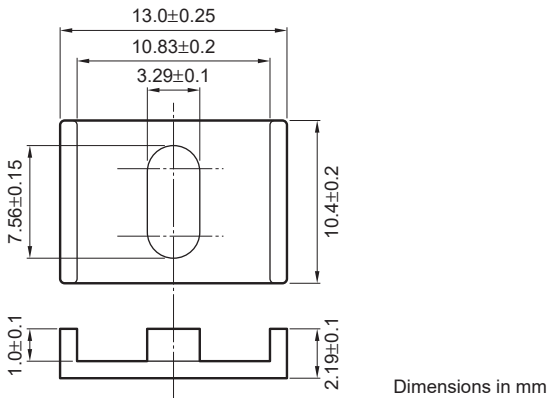

| Effective parameter | | | | | | Electrical characteristics | |
|---------------------------------------|--------------------------------|--------------------------------------|--------------------------------------|---------------------------------------|---------|---------------------------------------|-------------------------------------|
| Core factor | Effective magnetic path length | Effective cross-sectional area | Effective core volume | Cross-sectional winding area of core | Weigh | AL-value * | Core loss |
| C ₁ (mm ⁻¹) | ℓ _e (mm) | A _e (mm ²) | V _e (mm ³) | A _{cw} (mm ²) | (g/set) | (nH/N ²) 1kHz 0.5mA | (W)max. 100kHz 200mT 100°C |
| 0.667 | 15.4 | 23.1 | 357 | 7.54 | 2.0 | 2500±25% | 0.25 |

NI limit vs. AL-value (Typ.)

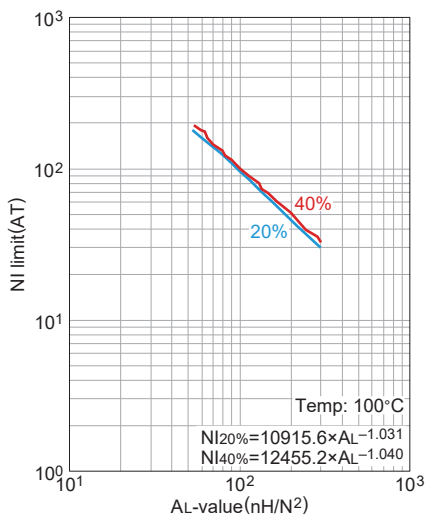

The 20% and 40% graph shows when a 20% and 40% drop from the initial AL-value has been made due to the DC superimposition.

AL-value vs. Air gap length (Typ.)

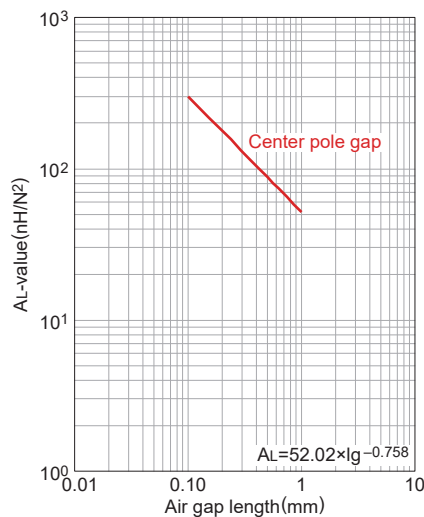

Measuring conditions
 • Coil : ø0.18 2UEW 100Ts
 • Frequency : 1kHz
 • Current level : 0.5mA
 • Ambient temperature : 25°C

⚠ Please be sure to request delivery specifications that provide further details on the features and specifications of the products for proper and safe use. Please note that the contents may change without any prior notice due to reasons such as upgrading.

Mn-Zn Planar series Part No.: PC95EL13X4.4-Z

SHAPES AND DIMENSIONS

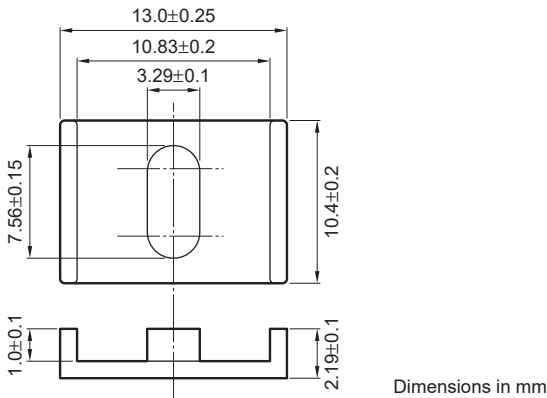

Dimensions in mm

| Effective parameter | | | | | | Electrical characteristics | | | | |
|---------------------------------------|--------------------------------|--------------------------------------|--------------------------------------|---------------------------------------|---------|---------------------------------------|----------------------------|------|------|-------|
| Core factor | Effective magnetic path length | Effective cross-sectional area | Effective core volume | Cross-sectional winding area of core | Weight | AL-value * | Core loss | | | |
| C ₁ (mm ⁻¹) | ℓ _e (mm) | A _e (mm ²) | V _e (mm ³) | A _{cw} (mm ²) | (g/set) | (nH/N ²) 1kHz 0.5mA | (W)max. 100kHz 200mT | 25°C | 80°C | 120°C |
| 0.667 | 15.4 | 23.1 | 357 | 7.54 | 2.0 | 3160±25% | 0.25 | 0.2 | 0.25 | |

NI limit vs. AL-value (Typ.)

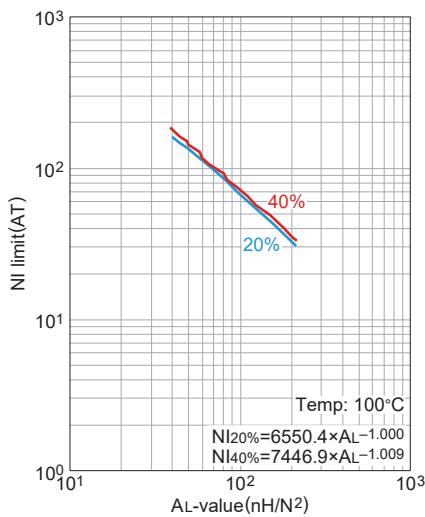

The 20% and 40% graph shows when a 20% and 40% drop from the initial AL-value has been made due to the DC superimposition.

AL-value vs. Air gap length (Typ.)

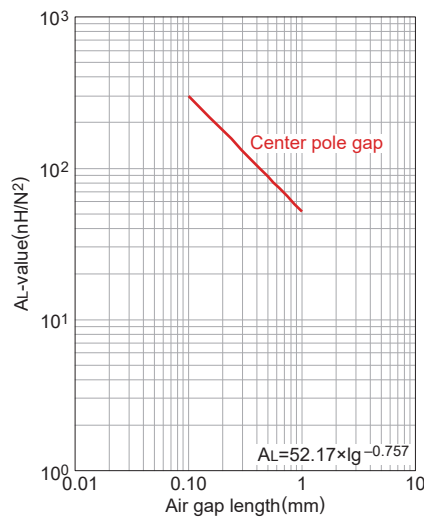

Measuring conditions
 • Coil : ø0.18 2UEW 100Ts
 • Frequency : 1kHz
 • Current level : 0.5mA
 • Ambient temperature : 25°C

⚠ Please be sure to request delivery specifications that provide further details on the features and specifications of the products for proper and safe use. Please note that the contents may change without any prior notice due to reasons such as upgrading.

Mn-Zn Planar series Part No.: PC90EL15.5X5.8-Z

SHAPES AND DIMENSIONS

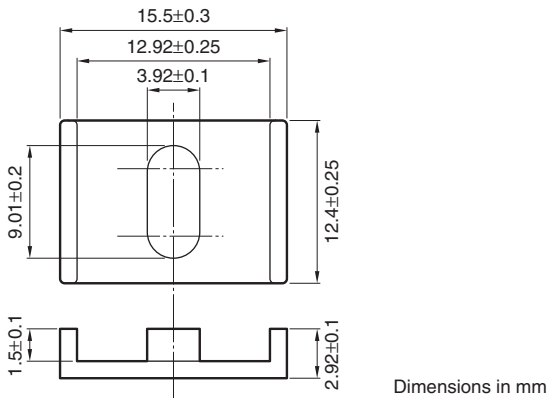

| Effective parameter | | | | | | Electrical characteristics | |
|---------------------------------------|--------------------------------|--------------------------------------|--------------------------------------|---------------------------------------|---------|---------------------------------------|-------------------------------------|
| Core factor | Effective magnetic path length | Effective cross-sectional area | Effective core volume | Cross-sectional winding area of core | Weight | AL-value * | Core loss |
| C ₁ (mm ⁻¹) | ℓ _e (mm) | A _e (mm ²) | V _e (mm ³) | A _{cw} (mm ²) | (g/set) | (nH/N ²) 1kHz 0.5mA | (W)max. 100kHz 200mT 100°C |
| 0.597 | 19.6 | 32.9 | 646 | 13.5 | 3.5 | 3000±25% | 0.5 |

NI limit vs. AL-value (Typ.)

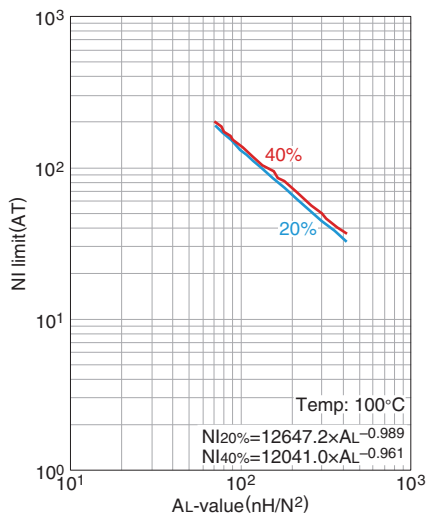

The 20% and 40% graph shows when a 20% and 40% drop from the initial AL-value has been made due to the DC superimposition.

AL-value vs. Air gap length (Typ.)

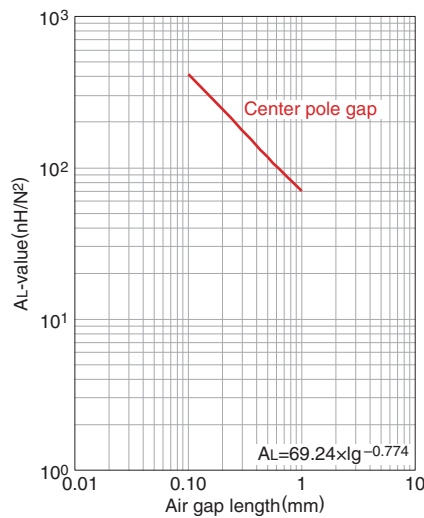

Measuring conditions
 • Coil : ø0.18 2UEW 100Ts
 • Frequency : 1kHz
 • Current level : 0.5mA
 • Ambient temperature : 25°C

⚠ Please be sure to request delivery specifications that provide further details on the features and specifications of the products for proper and safe use. Please note that the contents may change without any prior notice due to reasons such as upgrading.

Mn-Zn Planar series **Part No.: PC95EL15.5X5.8-Z**

SHAPES AND DIMENSIONS

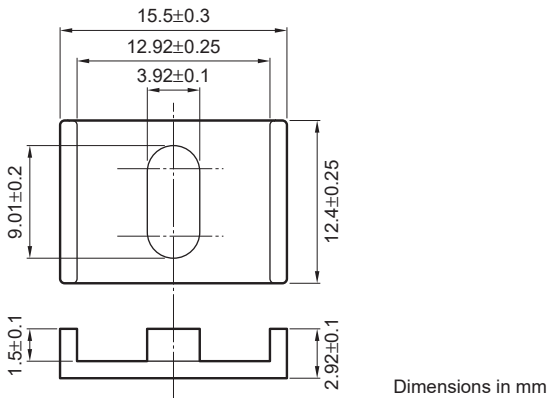

| Effective parameter | | | | | | Electrical characteristics | | | | |
|---------------------------------------|--------------------------------|--------------------------------------|--------------------------------------|---------------------------------------|---------|---------------------------------------|----------------------------|------|------|-------|
| Core factor | Effective magnetic path length | Effective cross-sectional area | Effective core volume | Cross-sectional winding area of core | Weight | AL-value * | Core loss | | | |
| C ₁ (mm ⁻¹) | ℓ _e (mm) | A _e (mm ²) | V _e (mm ³) | A _{cw} (mm ²) | (g/set) | (nH/N ²) 1kHz 0.5mA | (W)max. 100kHz 200mT | 25°C | 80°C | 120°C |
| 0.597 | 19.6 | 32.9 | 646 | 13.5 | 3.5 | 3680±25% | 0.5 | 0.45 | 0.5 | |

NI limit vs. AL-value (Typ.)

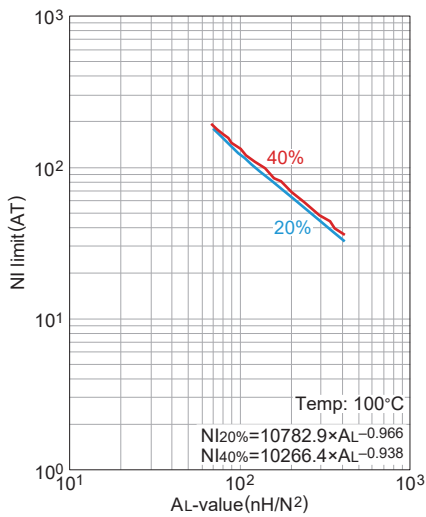

The 20% and 40% graph shows when a 20% and 40% drop from the initial AL-value has been made due to the DC superimposition.

AL-value vs. Air gap length (Typ.)

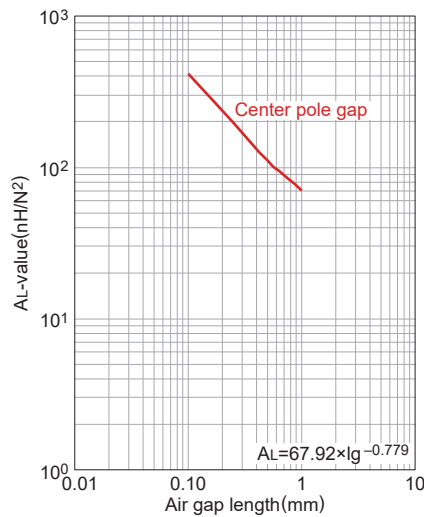

Measuring conditions
 • Coil : ø0.18 2UEW 100Ts
 • Frequency : 1kHz
 • Current level : 0.5mA
 • Ambient temperature : 25°C

⚠ Please be sure to request delivery specifications that provide further details on the features and specifications of the products for proper and safe use. Please note that the contents may change without any prior notice due to reasons such as upgrading.

Mn-Zn ELT Cores

SHAPES AND DIMENSIONS

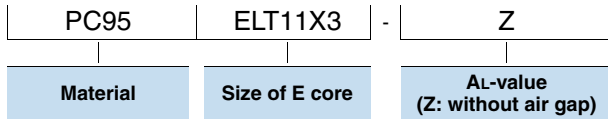
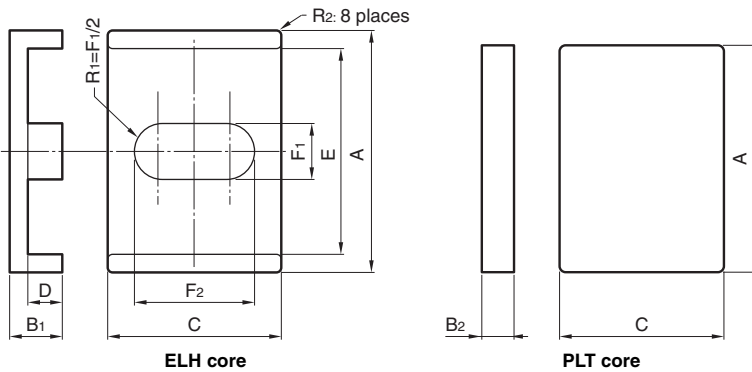

| Part No.(ELH+PLT) | Dimensions (mm) | | | | | | | | |
|-------------------|-----------------|----------------|----------------|------------|-----------|------------|----------------|----------------|----------------|
| | A | B ₁ | B ₂ | C | D | E | F ₁ | F ₂ | R ₂ |
| PC95ELT11X3-Z | 11.00±0.20 | 2.01±0.10 | 1.01±0.05 | 8.80±0.20 | 1.00±0.10 | 9.17±0.20 | 2.78±0.10 | 6.40±0.15 | 0.30 |
| PC90ELT11X3-Z | | | | | | | | | |
| PC95ELT11X4-Z | 11.00±0.20 | 3.01±0.10 | 1.01±0.05 | 8.80±0.20 | 2.00±0.10 | 9.17±0.20 | 2.78±0.10 | 6.40±0.15 | 0.30 |
| PC90ELT11X4-Z | | | | | | | | | |
| PC95ELT13X3.4-Z | 13.00±0.25 | 2.19±0.10 | 1.19±0.05 | 10.40±0.20 | 1.00±0.10 | 10.83±0.20 | 3.29±0.10 | 7.56±0.15 | 0.30 |
| PC90ELT13X3.4-Z | | | | | | | | | |
| PC95ELT13X4.4-Z | 13.00±0.25 | 3.19±0.10 | 1.19±0.05 | 10.40±0.20 | 2.00±0.10 | 10.83±0.20 | 3.29±0.10 | 7.56±0.15 | 0.30 |
| PC90ELT13X4.4-Z | | | | | | | | | |
| PC95ELT15.5X4.3-Z | 15.50±0.30 | 2.92±0.10 | 1.42±0.10 | 12.40±0.25 | 1.50±0.10 | 12.92±0.25 | 3.92±0.10 | 9.01±0.20 | 0.30 |
| PC90ELT15.5X4.3-Z | | | | | | | | | |
| PC95ELT15.5X5.8-Z | 15.50±0.30 | 4.42±0.10 | 1.42±0.10 | 12.40±0.25 | 3.00±0.10 | 12.92±0.25 | 3.92±0.10 | 9.01±0.20 | 0.30 |
| PC90ELT15.5X5.8-Z | | | | | | | | | |
| PC95ELT18X5.3-Z | 18.00±0.30 | 3.65±0.10 | 1.65±0.10 | 14.40±0.25 | 2.00±0.10 | 15.00±0.30 | 4.55±0.10 | 10.47±0.20 | 0.30 |
| PC90ELT18X5.3-Z | | | | | | | | | |

| Part No.(ELH+ELH) | Effective parameter | | | | | | | Electrical characteristics | |
|-------------------|---|---|---|--|--|---------------------------------------|--------------|--|---------------------------|
| | Core factor C ₁ (mm ⁻¹) | Effective magnetic path length ℓ _e (mm) | Effective cross-sectional area A _e (mm ²) | Effective core volume V _e (mm ³) | A _{min} . (mm ²) | A _{cw} (mm ²) | Weigh (g) | AL-value (nH/N ²) 1kHz 0.5mA 100Ts | |
| PC95ELT11X3-Z | 0.702 | 11.7 | 16.6 | 194 | 15.9 | 3.20 | 1.1 | Without air gap | 2590±25% |
| PC90ELT11X3-Z | | | | | | | | With air gap | 50±3% 80±5% 125±7% |
| PC95ELT11X4-Z | 0.826 | 13.7 | 16.5 | 226 | 15.9 | 6.39 | 1.3 | Without air gap | 2400±25% |
| PC90ELT11X4-Z | | | | | | | | With air gap | 50±3% 80±5% 125±7% |
| PC95ELT13X3.4-Z | 0.578 | 13.4 | 23.2 | 312 | 22.4 | 3.77 | 1.8 | Without air gap | 3390±25% |
| PC90ELT13X3.4-Z | | | | | | | | With air gap | 63±3% 100±5% 160±7% |
| PC95ELT13X4.4-Z | 0.667 | 15.4 | 23.1 | 357 | 22.4 | 7.54 | 2.0 | Without air gap | 3160±25% |
| PC90ELT13X4.4-Z | | | | | | | | With air gap | 63±3% 100±5% 160±7% |
| PC95ELT15.5X4.3-Z | 0.503 | 16.6 | 33.1 | 550 | 31.9 | 6.75 | 3.0 | Without air gap | 4340±25% |
| PC90ELT15.5X4.3-Z | | | | | | | | With air gap | 63±3% 100±3% 160±5% |
| PC95ELT15.5X5.8-Z | 0.597 | 19.6 | 32.9 | 646 | 31.9 | 13.5 | 3.5 | Without air gap | 3680±25% |
| PC90ELT15.5X5.8-Z | | | | | | | | With air gap | 63±3% 100±3% 160±5% |
| PC95ELT18X5.3-Z | 0.446 | 19.8 | 44.5 | 882 | 43.0 | 10.5 | 5.0 | Without air gap | 5330±25% |
| PC90ELT18X5.3-Z | | | | | | | | With air gap | 80±3% 125±3% 200±5% |

⚠ Please be sure to request delivery specifications that provide further details on the features and specifications of the products for proper and safe use.
Please note that the contents may change without any prior notice due to reasons such as upgrading.

Mn-Zn ELT Cores

SHAPES AND DIMENSIONS

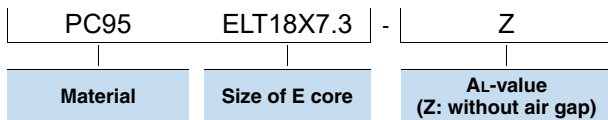
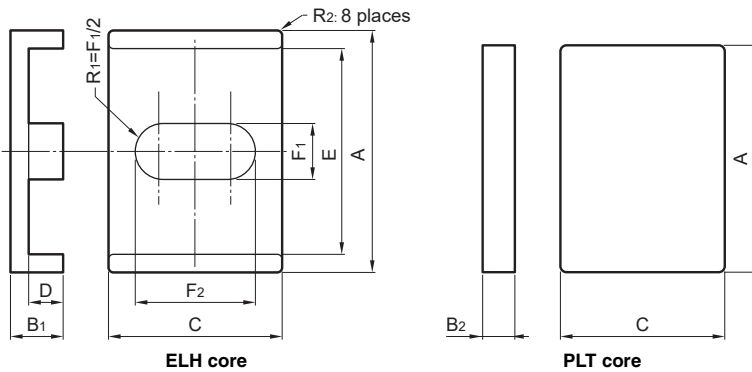

| Part No.(ELH+PLT) | Dimensions (mm) | | | | | | | | |
|-------------------|-----------------|----------------|----------------|------------|-----------|------------|----------------|----------------|----------------|
| | A | B ₁ | B ₂ | C | D | E | F ₁ | F ₂ | R ₂ |
| PC95ELT18X7.3-Z | 18.00±0.30 | 5.65±0.10 | 1.65±0.10 | 14.40±0.25 | 4.00±0.15 | 15.00±0.30 | 4.55±0.10 | 10.47±0.20 | 0.30 |
| PC90ELT18X7.3-Z | | | | | | | | | |
| PC95ELT20X5.7-Z | 20.00±0.35 | 3.83±0.10 | 1.83±0.10 | 16.00±0.30 | 2.00±0.10 | 16.67±0.30 | 5.06±0.15 | 11.63±0.20 | 0.50 |
| PC90ELT20X5.7-Z | | | | | | | | | |
| PC95ELT20X7.7-Z | 20.00±0.35 | 5.83±0.15 | 1.83±0.10 | 16.00±0.30 | 4.00±0.15 | 16.67±0.30 | 5.06±0.15 | 11.63±0.20 | 0.50 |
| PC90ELT20X7.7-Z | | | | | | | | | |
| PC95ELT22X6-Z | 22.00±0.40 | 4.02±0.10 | 2.02±0.10 | 17.60±0.30 | 2.00±0.10 | 18.33±0.35 | 5.56±0.15 | 12.79±0.25 | 0.50 |
| PC90ELT22X6-Z | | | | | | | | | |
| PC95ELT22X8-Z | 22.00±0.40 | 6.02±0.15 | 2.02±0.10 | 17.60±0.30 | 4.00±0.15 | 18.33±0.35 | 5.56±0.15 | 12.79±0.25 | 0.50 |
| PC90ELT22X8-Z | | | | | | | | | |
| PC95ELT25X6.6-Z | 25.00±0.45 | 4.29±0.10 | 2.29±0.10 | 20.00±0.35 | 2.00±0.10 | 20.83±0.35 | 6.32±0.15 | 14.54±0.25 | 0.50 |
| PC90ELT25X6.6-Z | | | | | | | | | |
| PC95ELT25X8.6-Z | 25.00±0.45 | 6.29±0.15 | 2.29±0.10 | 20.00±0.35 | 4.00±0.15 | 20.83±0.35 | 6.32±0.15 | 14.54±0.25 | 0.50 |
| PC90ELT25X8.6-Z | | | | | | | | | |

| Part No.(ELH+ELH) | Effective parameter | | | | | | | Electrical characteristics | |
|-------------------|---|---|---|--|--|---------------------------------------|--------------|--|--------|
| | Core factor C ₁ (mm ⁻¹) | Effective magnetic path length ℓ _e (mm) | Effective cross-sectional area A _e (mm ²) | Effective core volume V _e (mm ³) | A _{min} . (mm ²) | A _{cw} (mm ²) | Weigh (g) | AL-value (nH/N ²) 1kHz 0.5mA 100Ts | |
| PC95ELT18X7.3-Z | 0.538 | 23.8 | 44.3 | 1050 | 43.0 | 20.9 | 6.0 | 4760±25% | 80±3% |
| PC90ELT18X7.3-Z | | | | | | | | 3100±25% | 125±3% |
| PC95ELT20X5.7-Z | 0.393 | 21.6 | 54.9 | 1180 | 52.9 | 11.6 | 6.7 | 6270±25% | 80±3% |
| PC90ELT20X5.7-Z | | | | | | | | 4150±25% | 125±3% |
| PC95ELT20X7.7-Z | 0.469 | 25.6 | 54.6 | 1400 | 52.9 | 23.2 | 7.8 | 5630±25% | 80±3% |
| PC90ELT20X7.7-Z | | | | | | | | 3900±25% | 125±3% |
| PC95ELT22X6-Z | 0.351 | 23.4 | 66.6 | 1560 | 64.2 | 12.8 | 9.0 | 7250±25% | 100±3% |
| PC90ELT22X6-Z | | | | | | | | 4800±25% | 160±3% |
| PC95ELT22X8-Z | 0.413 | 27.3 | 66.2 | 1810 | 64.2 | 25.5 | 10 | 6540±25% | 100±3% |
| PC90ELT22X8-Z | | | | | | | | 4250±25% | 160±3% |
| PC95ELT25X6.6-Z | 0.302 | 26.0 | 86.0 | 2230 | 83.0 | 14.5 | 13 | 8600±25% | 100±3% |
| PC90ELT25X6.6-Z | | | | | | | | 6100±25% | 160±3% |
| PC95ELT25X8.6-Z | 0.350 | 30.0 | 85.6 | 2570 | 83.0 | 29.0 | 15 | 7540±25% | 100±3% |
| PC90ELT25X8.6-Z | | | | | | | | 5400±25% | 160±3% |

⚠ Please be sure to request delivery specifications that provide further details on the features and specifications of the products for proper and safe use.
Please note that the contents may change without any prior notice due to reasons such as upgrading.

Mn-Zn Planar series Part No.: PC90ELT11X3-Z

SHAPES AND DIMENSIONS

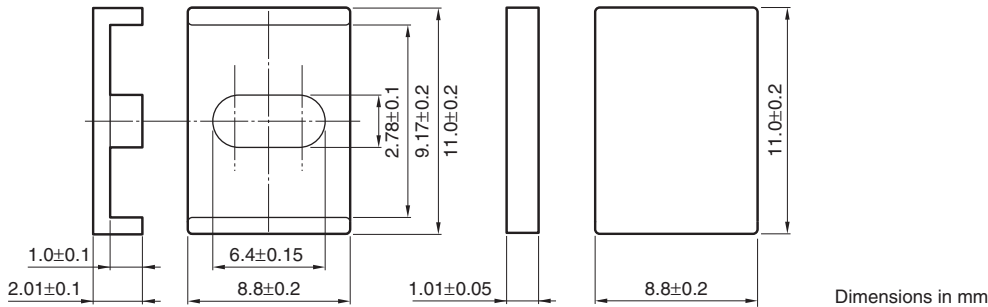

| Effective parameter | | | | | | Electrical characteristics | |
|---------------------------------------|--------------------------------|--------------------------------------|--------------------------------------|--------------------------------------|---------|---------------------------------------|-------------------------------------|
| Core factor | Effective magnetic path length | Effective cross-sectional area | Effective core volume | Cross-sectional winding area of core | Weight | AL-value * | Core loss |
| C ₁ (mm ⁻¹) | ℓ _e (mm) | A _e (mm ²) | V _e (mm ³) | Acw (mm ²) | (g/set) | (nH/N ²) 1kHz 0.5mA | (W)max. 100kHz 200mT 100°C |
| 0.702 | 11.7 | 16.6 | 194 | 3.20 | 1.1 | 1750±25% | 0.15 |

NI limit vs. AL-value (Typ.)

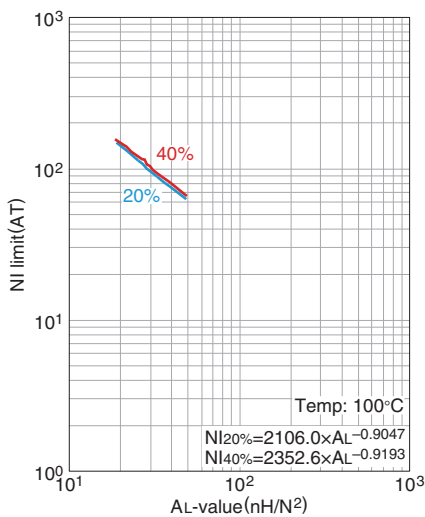

The 20% and 40% graph shows when a 20% and 40% drop from the initial AL-value has been made due to the DC superimposition.

AL-value vs. Air gap length (Typ.)

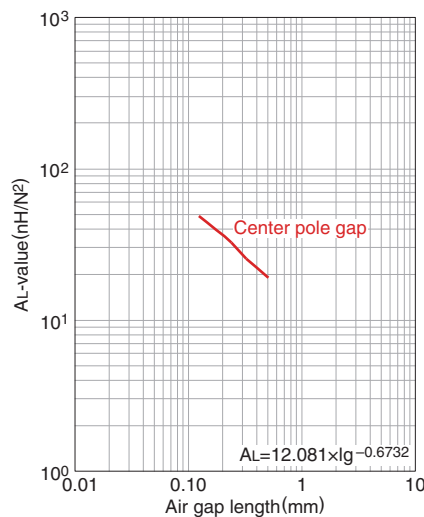

Measuring conditions
 • Coil : ø0.18 2UEW 100Ts
 • Frequency : 1kHz
 • Current level : 0.5mA
 • Ambient temperature : 25°C

⚠ Please be sure to request delivery specifications that provide further details on the features and specifications of the products for proper and safe use. Please note that the contents may change without any prior notice due to reasons such as upgrading.

Mn-Zn Planar series Part No.: PC95ELT11X3-Z

SHAPES AND DIMENSIONS

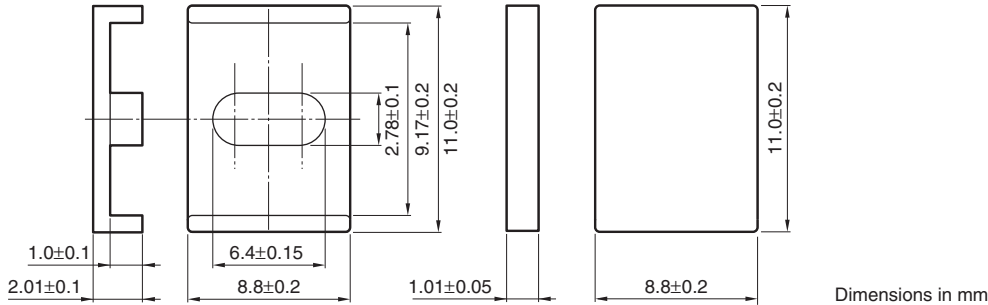

| Effective parameter | | | | | | Electrical characteristics | | | | |
|------------------------------|--------------------------------|--------------------------------|-----------------------------|--------------------------------------|---------|---------------------------------------|----------------------------|------|------|-------|
| Core factor | Effective magnetic path length | Effective cross-sectional area | Effective core volume | Cross-sectional winding area of core | Weight | AL-value * | Core loss | | | |
| C_1 (mm ⁻¹) | ℓ_e (mm) | A_e (mm ²) | V_e (mm ³) | A_{cw} (mm ²) | (g/set) | (nH/N ²) 1kHz 0.5mA | (W)max. 100kHz 200mT | 25°C | 80°C | 120°C |
| 0.702 | 11.7 | 16.6 | 194 | 3.20 | 1.1 | 2590±25% | 0.14 | 0.12 | 0.14 | |

NI limit vs. AL-value (Typ.)

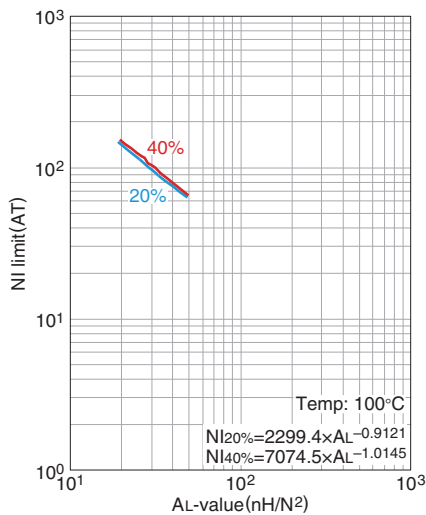

The 20% and 40% graph shows when a 20% and 40% drop from the initial AL-value has been made due to the DC superimposition.

AL-value vs. Air gap length (Typ.)

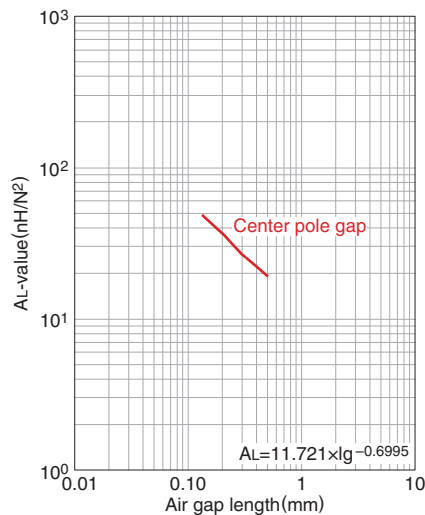

Measuring conditions
 • Coil : $\varnothing 0.18$ 2UEW 100Ts
 • Frequency : 1kHz
 • Current level : 0.5mA
 • Ambient temperature : 25°C

⚠ Please be sure to request delivery specifications that provide further details on the features and specifications of the products for proper and safe use. Please note that the contents may change without any prior notice due to reasons such as upgrading.

Mn-Zn Planar series Part No.: PC90ELT11X4-Z

SHAPES AND DIMENSIONS

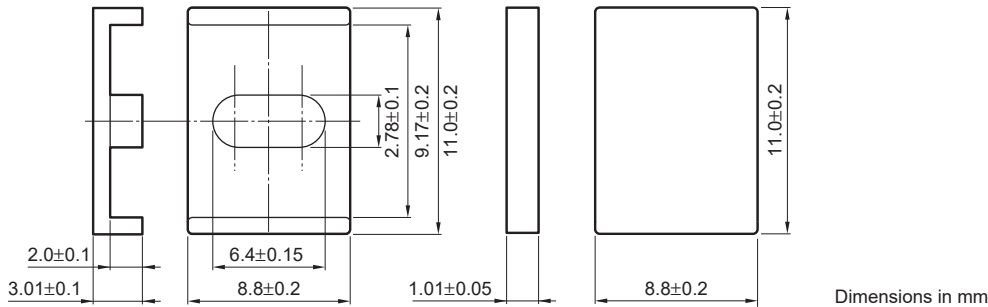

| Effective parameter | | | | | | Electrical characteristics | |
|---------------------------------------|--------------------------------|--------------------------------------|--------------------------------------|---------------------------------------|---------|---------------------------------------|-------------------------------------|
| Core factor | Effective magnetic path length | Effective cross-sectional area | Effective core volume | Cross-sectional winding area of core | Weigh | AL-value * | Core loss |
| C ₁ (mm ⁻¹) | ℓ _e (mm) | A _e (mm ²) | V _e (mm ³) | A _{cw} (mm ²) | (g/set) | (nH/N ²) 1kHz 0.5mA | (W)max. 100kHz 200mT 100°C |
| 0.826 | 13.7 | 16.5 | 226 | 6.39 | 1.3 | 1700±25% | 0.18 |

NI limit vs. AL-value (Typ.)

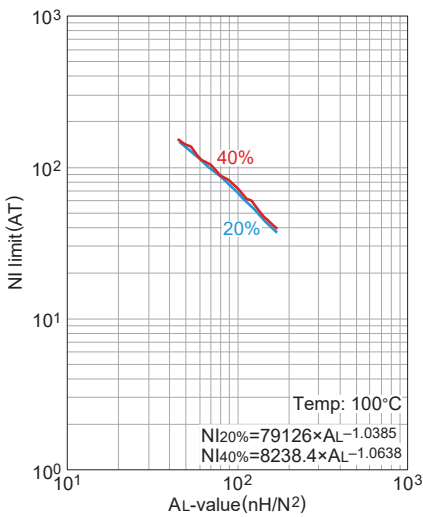

The 20% and 40% graph shows when a 20% and 40% drop from the initial AL-value has been made due to the DC superimposition.

AL-value vs. Air gap length (Typ.)

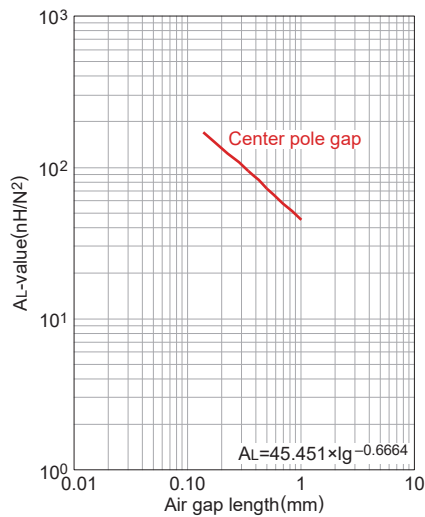

Measuring conditions
 • Coil : ø0.18 2UEW 100Ts
 • Frequency : 1kHz
 • Current level : 0.5mA
 • Ambient temperature : 25°C

⚠ Please be sure to request delivery specifications that provide further details on the features and specifications of the products for proper and safe use. Please note that the contents may change without any prior notice due to reasons such as upgrading.

Mn-Zn Planar series Part No.: PC95ELT11X4-Z

SHAPES AND DIMENSIONS

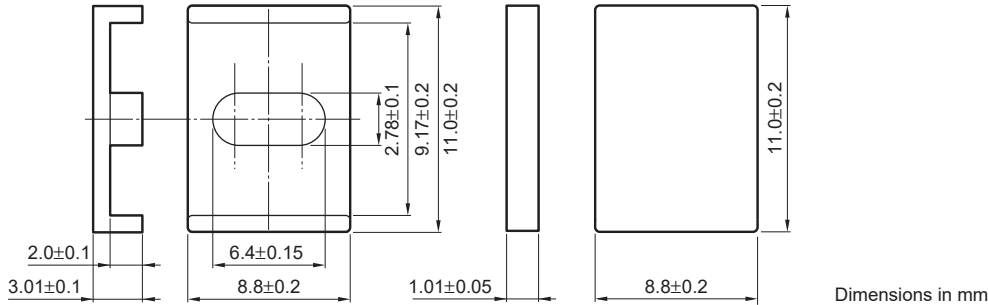

| Effective parameter | | | | | | Electrical characteristics | | | | |
|---------------------------------------|--------------------------------|--------------------------------------|--------------------------------------|---------------------------------------|---------|---------------------------------------|----------------------------|------|------|-------|
| Core factor | Effective magnetic path length | Effective cross-sectional area | Effective core volume | Cross-sectional winding area of core | Weight | AL-value * | Core loss | | | |
| C ₁ (mm ⁻¹) | ℓ _e (mm) | A _e (mm ²) | V _e (mm ³) | A _{cw} (mm ²) | (g/set) | (nH/N ²) 1kHz 0.5mA | (W)max. 100kHz 200mT | 25°C | 80°C | 120°C |
| 0.826 | 13.7 | 16.5 | 226 | 6.39 | 1.3 | 2400±25% | 0.16 | 0.15 | 0.16 | |

NI limit vs. AL-value (Typ.)

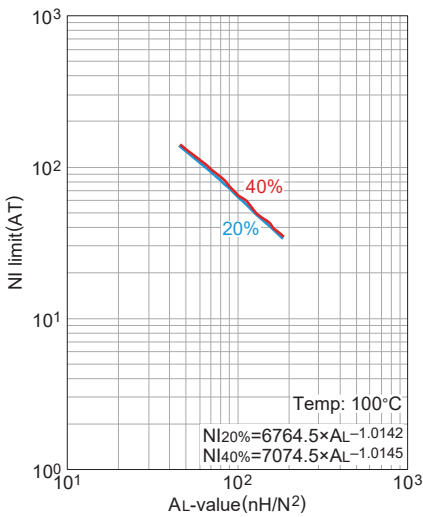

The 20% and 40% graph shows when a 20% and 40% drop from the initial AL-value has been made due to the DC superimposition.

AL-value vs. Air gap length (Typ.)

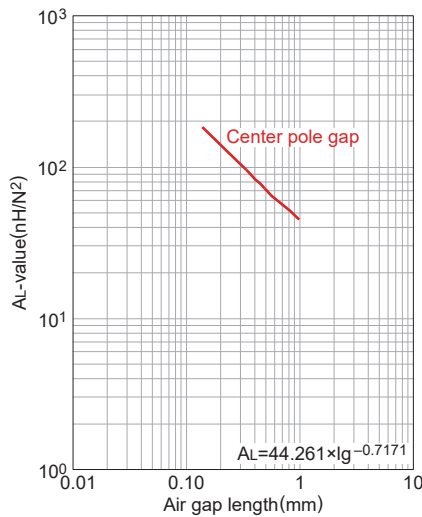

Measuring conditions
 • Coil : ø0.18 2UEW 100Ts
 • Frequency : 1kHz
 • Current level : 0.5mA
 • Ambient temperature : 25°C

⚠ Please be sure to request delivery specifications that provide further details on the features and specifications of the products for proper and safe use. Please note that the contents may change without any prior notice due to reasons such as upgrading.

Mn-Zn Planar series Part No.: PC90ELT13X3.4-Z

SHAPES AND DIMENSIONS

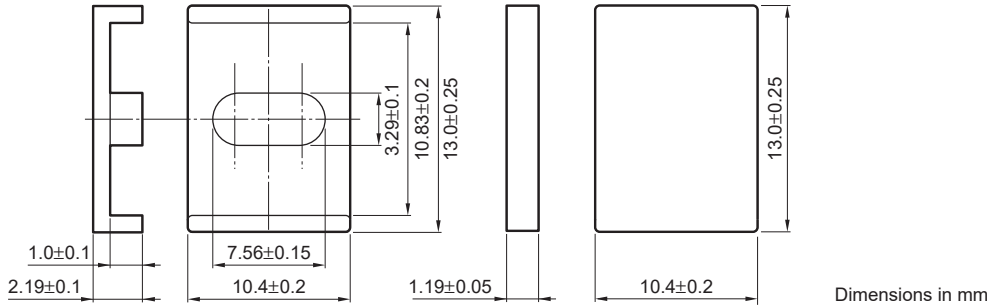

| Effective parameter | | | | | | Electrical characteristics | |
|---------------------------------------|--------------------------------|--------------------------------------|--------------------------------------|---------------------------------------|---------|---------------------------------------|-------------------------------------|
| Core factor | Effective magnetic path length | Effective cross-sectional area | Effective core volume | Cross-sectional winding area of core | Weight | AL-value * | Core loss |
| C ₁ (mm ⁻¹) | ℓ _e (mm) | A _e (mm ²) | V _e (mm ³) | A _{cw} (mm ²) | (g/set) | (nH/N ²) 1kHz 0.5mA | (W)max. 100kHz 200mT 100°C |
| 0.578 | 13.4 | 23.2 | 312 | 3.77 | 1.8 | 2400±25% | 0.3 |

NI limit vs. AL-value (Typ.)

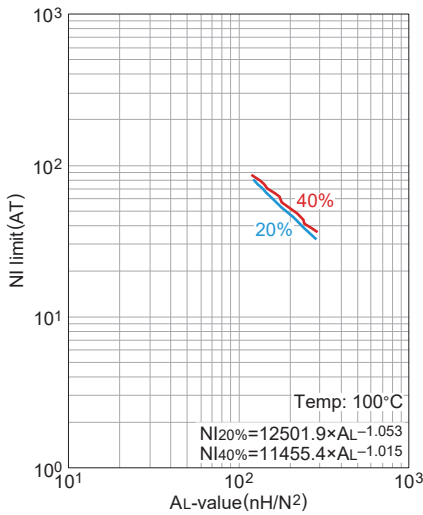

The 20% and 40% graph shows when a 20% and 40% drop from the initial AL-value has been made due to the DC superimposition.

AL-value vs. Air gap length (Typ.)

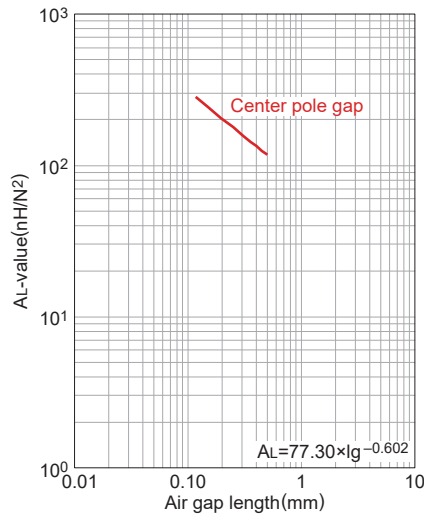

Measuring conditions
 • Coil : ø0.18 2UEW 100Ts
 • Frequency : 1kHz
 • Current level : 0.5mA
 • Ambient temperature : 25°C

⚠ Please be sure to request delivery specifications that provide further details on the features and specifications of the products for proper and safe use. Please note that the contents may change without any prior notice due to reasons such as upgrading.

Mn-Zn Planar series Part No.: PC95ELT13X3.4-Z

SHAPES AND DIMENSIONS

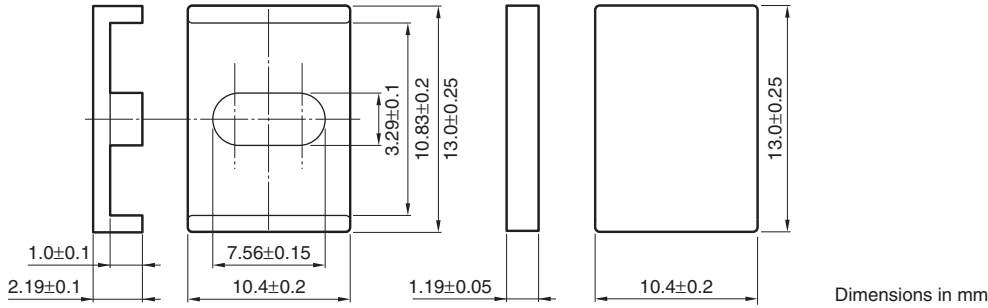

| Effective parameter | | | | | | Electrical characteristics | | | | |
|------------------------------|--------------------------------|--------------------------------|-----------------------------|--------------------------------------|---------|---------------------------------------|----------------------------|------|------|-------|
| Core factor | Effective magnetic path length | Effective cross-sectional area | Effective core volume | Cross-sectional winding area of core | Weight | AL-value * | Core loss | | | |
| C_1 (mm ⁻¹) | ℓ_e (mm) | A_e (mm ²) | V_e (mm ³) | A_{cw} (mm ²) | (g/set) | (nH/N ²) 1kHz 0.5mA | (W)max. 100kHz 200mT | 25°C | 80°C | 120°C |
| 0.578 | 13.4 | 23.2 | 312 | 3.77 | 1.8 | 3390±25% | 0.3 | 0.28 | 0.3 | |

NI limit vs. AL-value (Typ.)

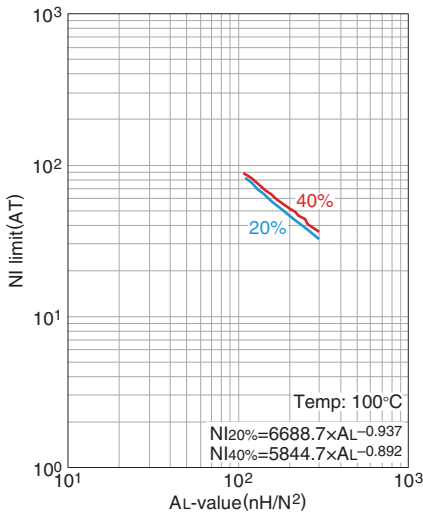

The 20% and 40% graph shows when a 20% and 40% drop from the initial AL-value has been made due to the DC superimposition.

AL-value vs. Air gap length (Typ.)

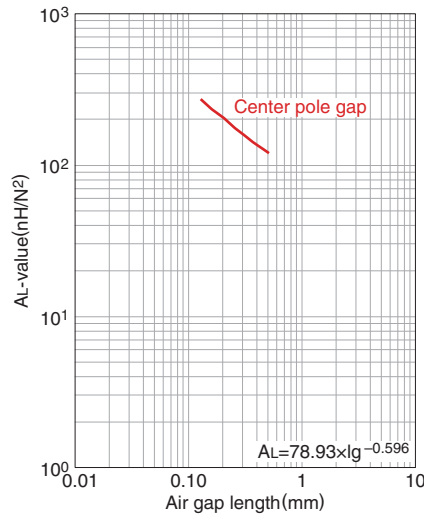

Measuring conditions
 • Coil : $\phi 0.18$ 2UEW 100Ts
 • Frequency : 1kHz
 • Current level : 0.5mA
 • Ambient temperature : 25°C

⚠ Please be sure to request delivery specifications that provide further details on the features and specifications of the products for proper and safe use. Please note that the contents may change without any prior notice due to reasons such as upgrading.

Mn-Zn Planar series Part No.: PC90ELT13X4.4-Z

SHAPES AND DIMENSIONS

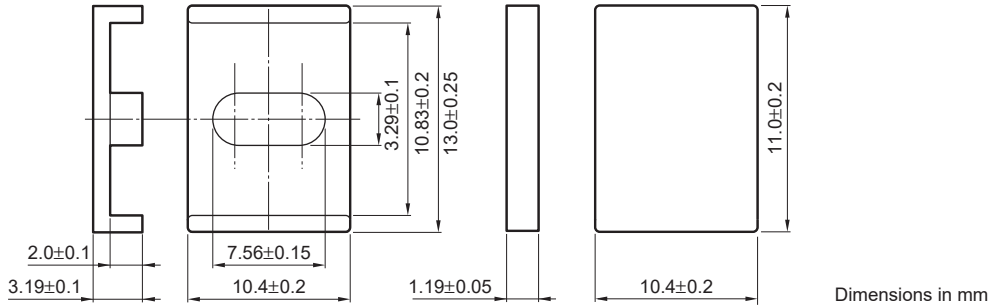

| Effective parameter | | | | | | Electrical characteristics | |
|---------------------------------------|--------------------------------|--------------------------------------|--------------------------------------|---------------------------------------|---------|---------------------------------------|-------------------------------------|
| Core factor | Effective magnetic path length | Effective cross-sectional area | Effective core volume | Cross-sectional winding area of core | Weight | AL-value * | Core loss |
| C ₁ (mm ⁻¹) | ℓ _e (mm) | A _e (mm ²) | V _e (mm ³) | A _{cw} (mm ²) | (g/set) | (nH/N ²) 1kHz 0.5mA | (W)max. 100kHz 200mT 100°C |
| 0.667 | 15.4 | 23.1 | 357 | 7.54 | 2.0 | 2300±25% | 0.3 |

NI limit vs. AL-value (Typ.)

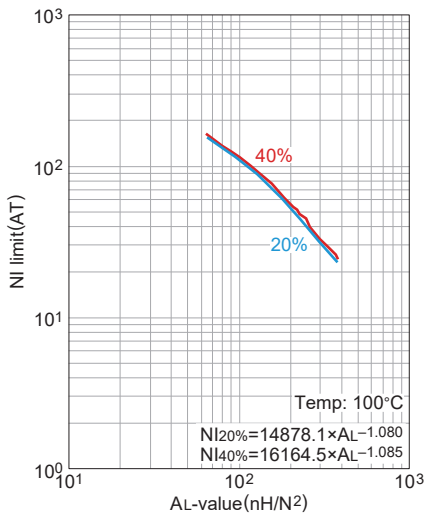

The 20% and 40% graph shows when a 20% and 40% drop from the initial AL-value has been made due to the DC superimposition.

AL-value vs. Air gap length (Typ.)

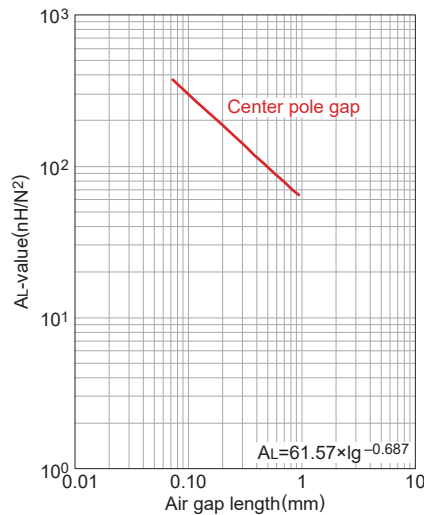

Measuring conditions
 • Coil : ø0.18 2UEW 100Ts
 • Frequency : 1kHz
 • Current level : 0.5mA
 • Ambient temperature : 25°C

⚠ Please be sure to request delivery specifications that provide further details on the features and specifications of the products for proper and safe use. Please note that the contents may change without any prior notice due to reasons such as upgrading.

Mn-Zn Planar series Part No.: PC95ELT13X4.4-Z

SHAPES AND DIMENSIONS

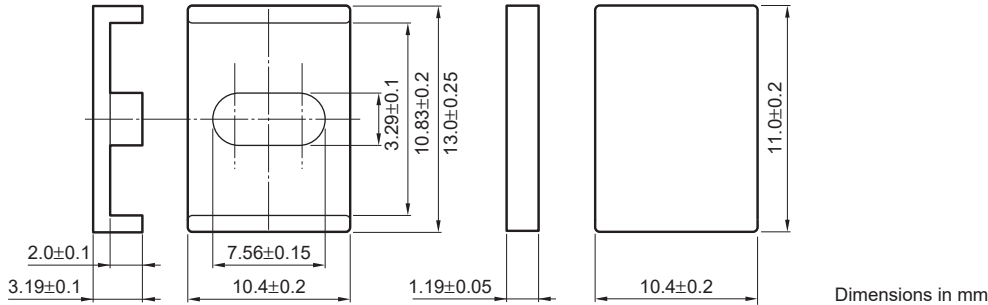

| Effective parameter | | | | | | Electrical characteristics | | | | |
|-------------------------------|--------------------------------|--------------------------------|----------------------------|--------------------------------------|---------|---|----------------------------|------|------|-------|
| Core factor | Effective magnetic path length | Effective cross-sectional area | Effective core volume | Cross-sectional winding area of core | Weight | AL-value * | Core loss | | | |
| C_1 (mm^{-1}) | ℓ_e (mm) | A_e (mm^2) | V_e (mm^3) | A_{cw} (mm^2) | (g/set) | (nH/N^2) 1kHz 0.5mA | (W)max. 100kHz 200mT | 25°C | 80°C | 120°C |
| 0.667 | 15.4 | 23.1 | 357 | 7.54 | 2.0 | 3160±25% | 0.3 | 0.28 | 0.3 | |

NI limit vs. AL-value (Typ.)

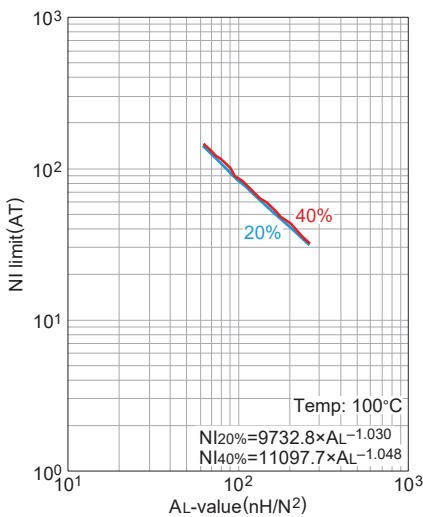

The 20% and 40% graph shows when a 20% and 40% drop from the initial AL-value has been made due to the DC superimposition.

AL-value vs. Air gap length (Typ.)

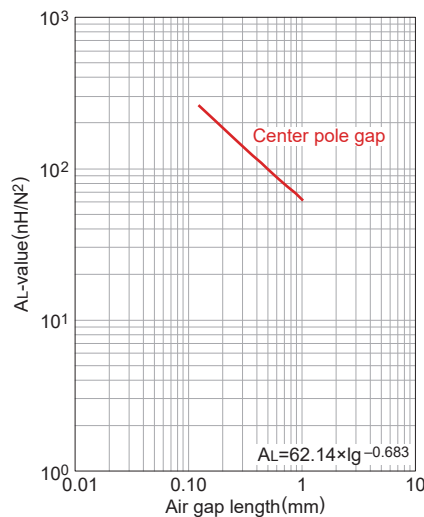

Measuring conditions
 • Coil : $\phi 0.18$ 2UEW 100Ts
 • Frequency : 1kHz
 • Current level : 0.5mA
 • Ambient temperature : 25°C

⚠ Please be sure to request delivery specifications that provide further details on the features and specifications of the products for proper and safe use. Please note that the contents may change without any prior notice due to reasons such as upgrading.

Mn-Zn Planar series Part No.: PC90ELT15.5X4.3-Z

SHAPES AND DIMENSIONS

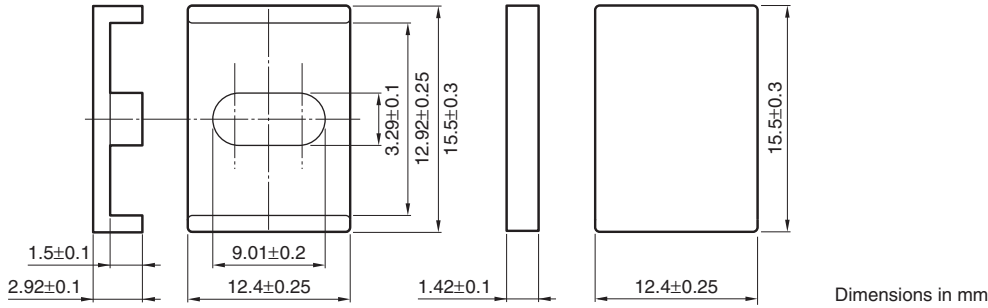

| Effective parameter | | | | | | Electrical characteristics | |
|------------------------------|--------------------------------|--------------------------------|-----------------------------|--------------------------------------|---------|---------------------------------------|-------------------------------------|
| Core factor | Effective magnetic path length | Effective cross-sectional area | Effective core volume | Cross-sectional winding area of core | Weigh | AL-value * | Core loss |
| C_1 (mm ⁻¹) | ℓ_e (mm) | A_e (mm ²) | V_e (mm ³) | A_{cw} (mm ²) | (g/set) | (nH/N ²) 1kHz 0.5mA | (W)max. 100kHz 200mT 100°C |
| 0.503 | 16.6 | 33.1 | 550 | 6.75 | 3.0 | 2900±25% | 0.5 |

NI limit vs. AL-value (Typ.)

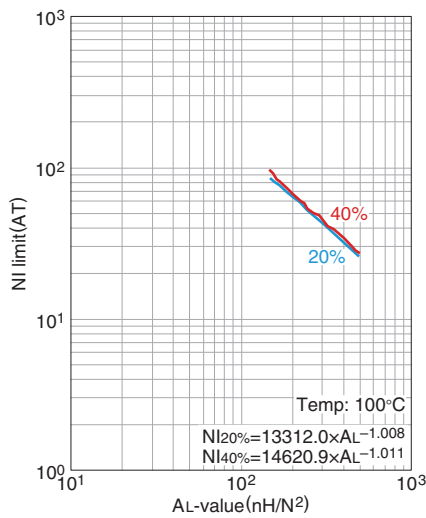

The 20% and 40% graph shows when a 20% and 40% drop from the initial AL-value has been made due to the DC superimposition.

AL-value vs. Air gap length (Typ.)

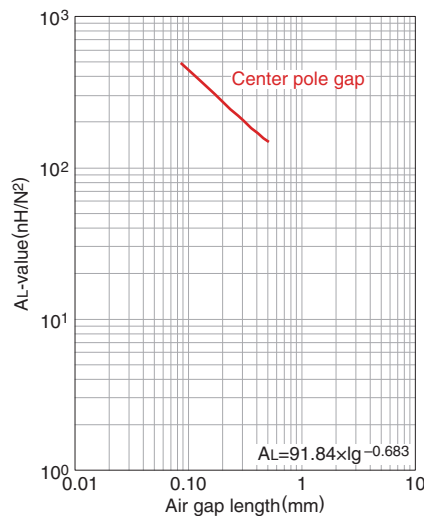

Measuring conditions
 • Coil : $\phi 0.18$ 2UEW 100Ts
 • Frequency : 1kHz
 • Current level : 0.5mA
 • Ambient temperature : 25°C

⚠ Please be sure to request delivery specifications that provide further details on the features and specifications of the products for proper and safe use. Please note that the contents may change without any prior notice due to reasons such as upgrading.

Mn-Zn Planar series Part No.: PC95ELT15.5X4.3-Z

SHAPES AND DIMENSIONS

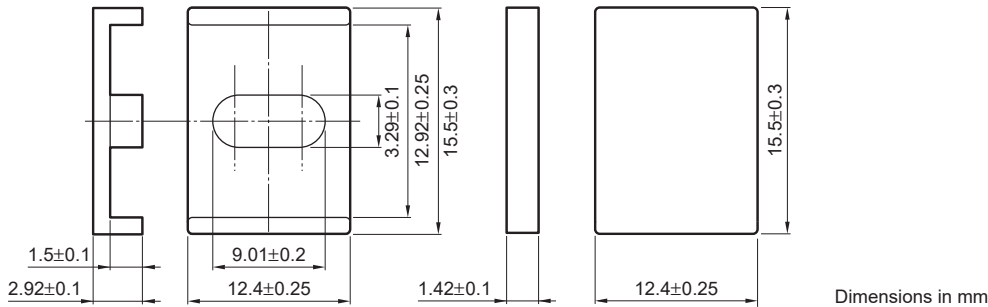

| Effective parameter | | | | | | Electrical characteristics | | | | |
|---------------------------------------|--------------------------------|--------------------------------------|--------------------------------------|---------------------------------------|---------|---------------------------------------|----------------------------|------|------|-------|
| Core factor | Effective magnetic path length | Effective cross-sectional area | Effective core volume | Cross-sectional winding area of core | Weigh | AL-value * | Core loss | | | |
| C ₁ (mm ⁻¹) | ℓ _e (mm) | A _e (mm ²) | V _e (mm ³) | A _{cw} (mm ²) | (g/set) | (nH/N ²) 1kHz 0.5mA | (W)max. 100kHz 200mT | 25°C | 80°C | 120°C |
| 0.503 | 16.6 | 33.1 | 550 | 6.75 | 3.0 | 4340±25% | 0.5 | 0.45 | 0.5 | |

NI limit vs. AL-value (Typ.)

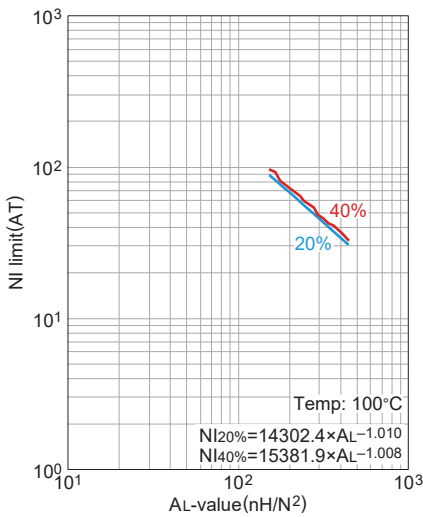

The 20% and 40% graph shows when a 20% and 40% drop from the initial AL-value has been made due to the DC superimposition.

AL-value vs. Air gap length (Typ.)

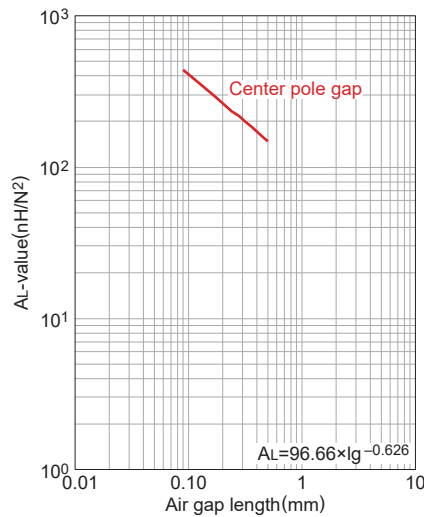

Measuring conditions
 • Coil : ø0.18 2UEW 100Ts
 • Frequency : 1kHz
 • Current level : 0.5mA
 • Ambient temperature : 25°C

⚠ Please be sure to request delivery specifications that provide further details on the features and specifications of the products for proper and safe use. Please note that the contents may change without any prior notice due to reasons such as upgrading.

Mn-Zn Planar series Part No.: PC90ELT18X7.3-Z

SHAPES AND DIMENSIONS

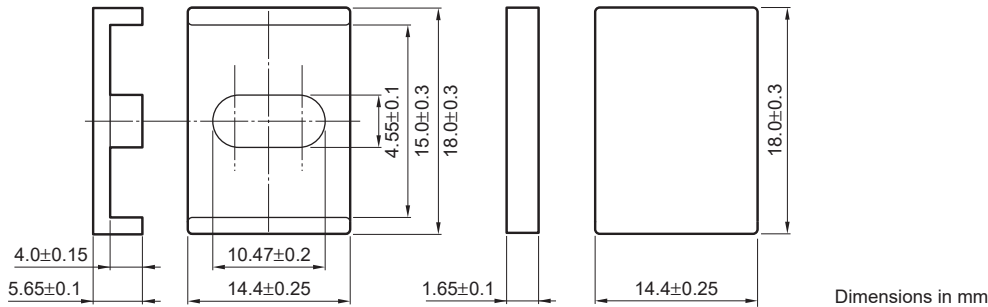

| Effective parameter | | | | | | Electrical characteristics | |
|---------------------------------------|--------------------------------|--------------------------------------|--------------------------------------|---------------------------------------|---------|---------------------------------------|-------------------------------------|
| Core factor | Effective magnetic path length | Effective cross-sectional area | Effective core volume | Cross-sectional winding area of core | Weight | AL-value * | Core loss |
| C ₁ (mm ⁻¹) | ℓ _e (mm) | A _e (mm ²) | V _e (mm ³) | A _{cw} (mm ²) | (g/set) | (nH/N ²) 1kHz 0.5mA | (W)max. 100kHz 200mT 100°C |
| 0.538 | 23.8 | 44.3 | 1050 | 20.9 | 6.0 | 3100±25% | 0.7 |

NI limit vs. AL-value (Typ.)

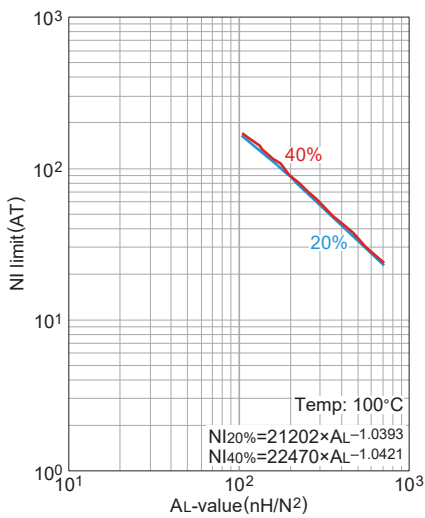

The 20% and 40% graph shows when a 20% and 40% drop from the initial AL-value has been made due to the DC superimposition.

AL-value vs. Air gap length (Typ.)

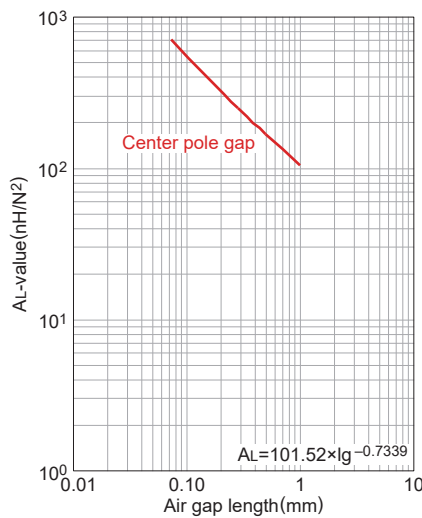

Measuring conditions
 • Coil : ø0.18 2UEW 100Ts
 • Frequency : 1kHz
 • Current level : 0.5mA
 • Ambient temperature : 25°C

⚠ Please be sure to request delivery specifications that provide further details on the features and specifications of the products for proper and safe use. Please note that the contents may change without any prior notice due to reasons such as upgrading.

Mn-Zn Planar series Part No.: PC95ELT18X7.3-Z

SHAPES AND DIMENSIONS

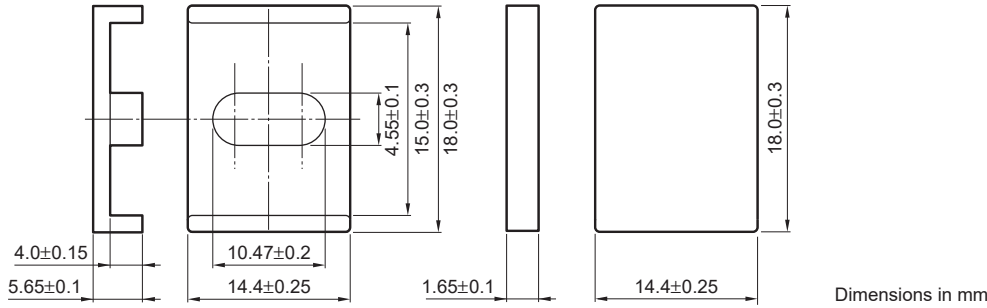

| Effective parameter | | | | | | Electrical characteristics | | | | |
|---------------------------------------|--------------------------------|--------------------------------------|--------------------------------------|---------------------------------------|---------|---------------------------------------|----------------------------|------|------|-------|
| Core factor | Effective magnetic path length | Effective cross-sectional area | Effective core volume | Cross-sectional winding area of core | Weigh | AL-value * | Core loss | | | |
| C ₁ (mm ⁻¹) | ℓ _e (mm) | A _e (mm ²) | V _e (mm ³) | A _{cw} (mm ²) | (g/set) | (nH/N ²) 1kHz 0.5mA | (W)max. 100kHz 200mT | 25°C | 80°C | 120°C |
| 0.538 | 23.8 | 44.3 | 1050 | 20.9 | 6.0 | 4760±25% | 0.6 | 0.55 | 0.6 | |

NI limit vs. AL-value (Typ.)

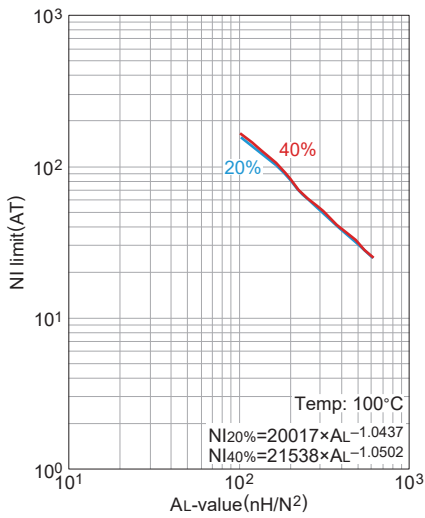

The 20% and 40% graph shows when a 20% and 40% drop from the initial AL-value has been made due to the DC superimposition.

AL-value vs. Air gap length (Typ.)

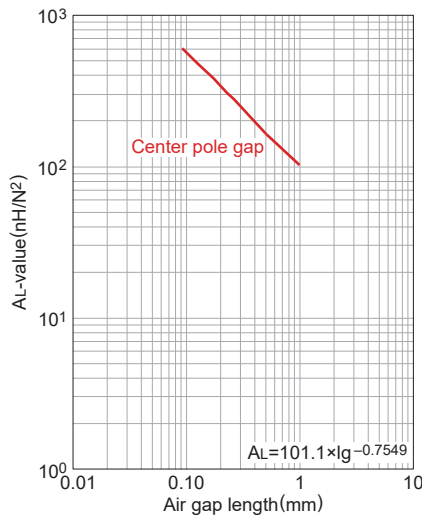

Measuring conditions
 • Coil : ø0.18 2UEW 100Ts
 • Frequency : 1kHz
 • Current level : 0.5mA
 • Ambient temperature : 25°C

⚠ Please be sure to request delivery specifications that provide further details on the features and specifications of the products for proper and safe use. Please note that the contents may change without any prior notice due to reasons such as upgrading.

Mn-Zn Planar series Part No.: PC90ELT25X8.6-Z

SHAPES AND DIMENSIONS

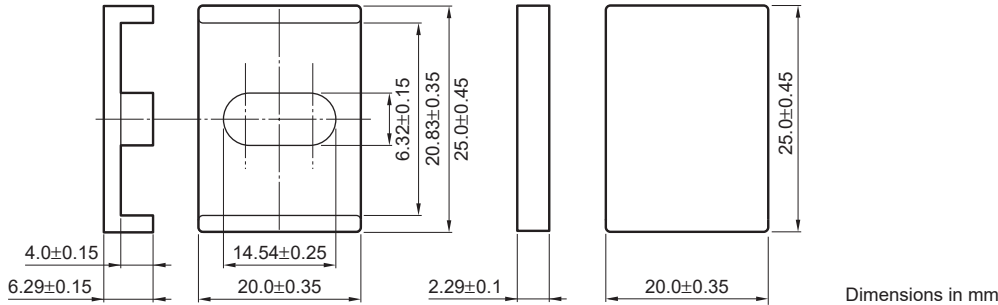

| Effective parameter | | | | | | Electrical characteristics | |
|---------------------------------------|--------------------------------|--------------------------------------|--------------------------------------|--------------------------------------|---------|---------------------------------------|-------------------------------------|
| Core factor | Effective magnetic path length | Effective cross-sectional area | Effective core volume | Cross-sectional winding area of core | Weigh | AL-value * | Core loss |
| C ₁ (mm ⁻¹) | ℓ _e (mm) | A _e (mm ²) | V _e (mm ³) | Acw (mm ²) | (g/set) | (nH/N ²) 1kHz 0.5mA | (W)max. 100kHz 200mT 100°C |
| 0.350 | 30.0 | 85.6 | 2570 | 29.0 | 15 | 5400±25% | 1.8 |

NI limit vs. AL-value (Typ.)

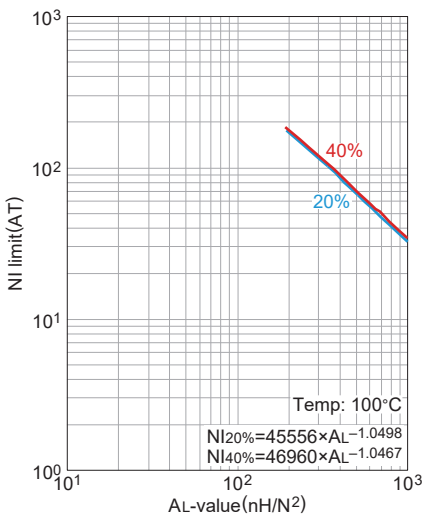

The 20% and 40% graph shows when a 20% and 40% drop from the initial AL-value has been made due to the DC superimposition.

AL-value vs. Air gap length (Typ.)

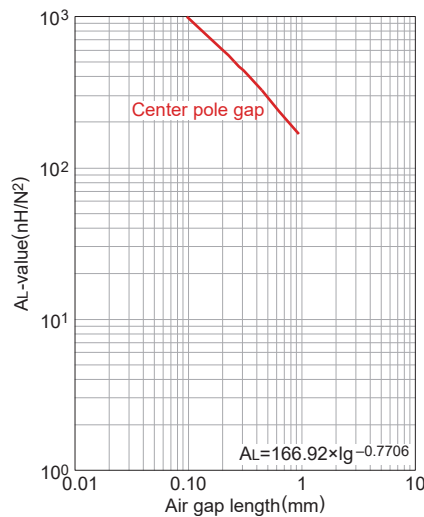

Measuring conditions
 • Coil : ø0.18 2UEW 100Ts
 • Frequency : 1kHz
 • Current level : 0.5mA
 • Ambient temperature : 25°C

⚠ Please be sure to request delivery specifications that provide further details on the features and specifications of the products for proper and safe use. Please note that the contents may change without any prior notice due to reasons such as upgrading.

Mn-Zn Planar series Part No.: PC95ELT25X8.6-Z

SHAPES AND DIMENSIONS

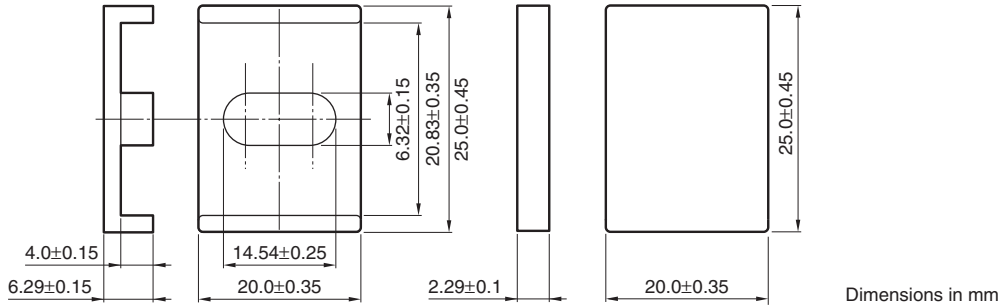

| Effective parameter | | | | | | Electrical characteristics | | | |
|-------------------------------|--------------------------------|--------------------------------|----------------------------|--------------------------------------|---------|--------------------------------------|------------------------------------|------|-------|
| Core factor | Effective magnetic path length | Effective cross-sectional area | Effective core volume | Cross-sectional winding area of core | Weight | AL-value * | Core loss | | |
| C_1 (mm^{-1}) | ℓ_e (mm) | A_e (mm^2) | V_e (mm^3) | A_{cw} (mm^2) | (g/set) | (nH/N^2) 1kHz 0.5mA | (W)max. 100kHz 200mT 25°C | 80°C | 120°C |
| 0.350 | 30.0 | 85.6 | 2570 | 29.0 | 15 | 7540±25% | 1.6 | 1.5 | 1.6 |

NI limit vs. AL-value (Typ.)

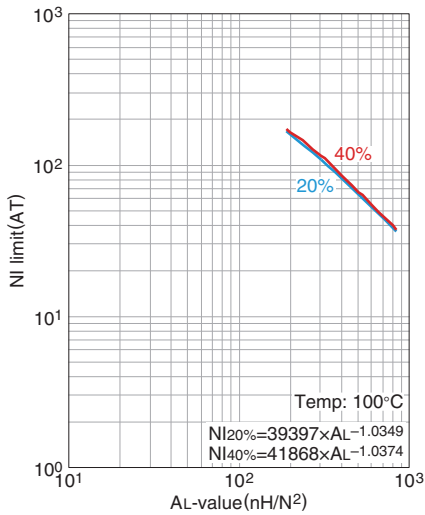

The 20% and 40% graph shows when a 20% and 40% drop from the initial AL-value has been made due to the DC superimposition.

AL-value vs. Air gap length (Typ.)

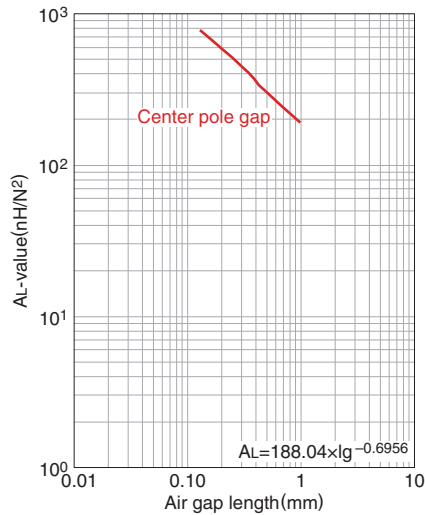

Measuring conditions
 • Coil : $\phi 0.18$ 2UEW 100Ts
 • Frequency : 1kHz
 • Current level : 0.5mA
 • Ambient temperature : 25°C

⚠ Please be sure to request delivery specifications that provide further details on the features and specifications of the products for proper and safe use. Please note that the contents may change without any prior notice due to reasons such as upgrading.

Mn-Zn PQI Cores

SHAPES AND DIMENSIONS

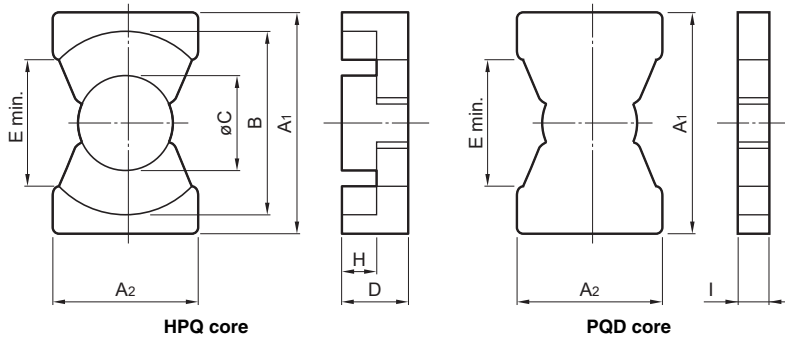

| | | | |
|----------|----------------|---|----------------------------------|
| PC95 | PQI16/7.8Z | - | 12 |
| Material | Size of E core | | AL-value (Z: without air gap) |

| Part No.(HPQ+PQD) | Dimensions (mm) | | | | | | | |
|-------------------|-----------------|------------|------------|------------|-----------|--------|-----------|-----------|
| | A1 | A2 | B | øC | D | E min. | H | I |
| PC95PQI16/7.8Z-12 | 16.40±0.30 | 11.20±0.30 | 14.40±0.30 | 7.00±0.20 | 5.40±0.10 | 9.60 | 3.05±0.15 | 2.35±0.10 |
| PC90PQI16/7.8Z-12 | | | | | | | | |
| PC95PQI20/9Z-12 | 20.50±0.40 | 14.00±0.40 | 18.00±0.40 | 8.80±0.20 | 6.00±0.10 | 12.00 | 3.05±0.15 | 2.95±0.10 |
| PC90PQI20/9Z-12 | | | | | | | | |
| PC95PQI26/12Z-12 | 26.50±0.45 | 19.00±0.45 | 22.50±0.45 | 12.00±0.20 | 7.30±0.10 | 15.50 | 3.10±0.15 | 4.20±0.10 |
| PC90PQI26/12Z-12 | | | | | | | | |

| Part No.(ELH+ELH) | Effective parameter | | | | | | | Electrical characteristics | |
|-------------------|---|---|---|--|--|---------------------------------------|--------------|--|--------|
| | Core factor C ₁ (mm ⁻¹) | Effective magnetic path length ℓ _e (mm) | Effective cross-sectional area A _e (mm ²) | Effective core volume V _e (mm ³) | A _{min} . (mm ²) | A _{cw} (mm ²) | Weigh (g) | AL-value (nH/N ²) 1kHz 0.5mA 100Ts | |
| PC95PQI16/7.8Z-12 | 0.467 | 19.5 | 41.8 | 815 | 37.6 | 11.3 | 5.0 | 4910±25% | 63±3% |
| PC90PQI16/7.8Z-12 | | | | | | | | 3600±25% | 100±5% |
| PC95PQI20/9Z-12 | 0.346 | 22.9 | 66.0 | 1510 | 59.3 | 14.0 | 9.0 | 7070±25% | 100±3% |
| PC90PQI20/9Z-12 | | | | | | | | 5200±25% | 160±5% |
| PC95PQI26/12Z-12 | 0.224 | 27.7 | 123 | 3410 | 109 | 16.3 | 21 | 11950±25% | 100±3% |
| PC90PQI26/12Z-12 | | | | | | | | 8600±25% | 160±3% |

⚠ Please be sure to request delivery specifications that provide further details on the features and specifications of the products for proper and safe use.
Please note that the contents may change without any prior notice due to reasons such as upgrading.

Mn-Zn Planar series Part No.: PC90PQI16/7.8Z-12

SHAPES AND DIMENSIONS

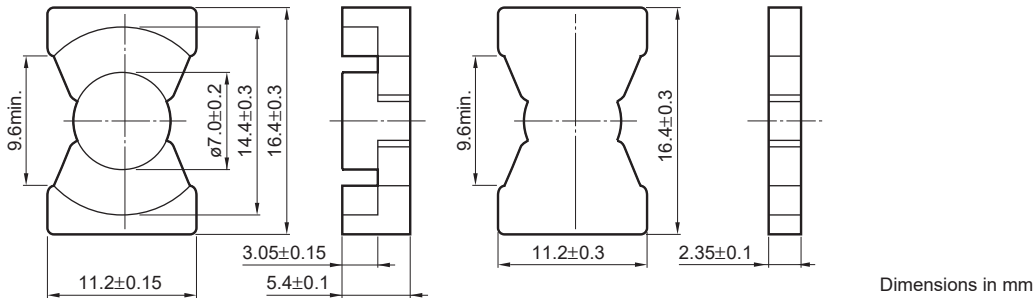

| Effective parameter | | | | | | Electrical characteristics | |
|------------------------------|--------------------------------|--------------------------------|-----------------------------|--------------------------------------|---------|---------------------------------------|-------------------------------------|
| Core factor | Effective magnetic path length | Effective cross-sectional area | Effective core volume | Cross-sectional winding area of core | Weigh | AL-value * | Core loss |
| C_1 (mm ⁻¹) | ℓ_e (mm) | A_e (mm ²) | V_e (mm ³) | A_{cw} (mm ²) | (g/set) | (nH/N ²) 1kHz 0.5mA | (W)max. 100kHz 200mT 100°C |
| 0.467 | 19.5 | 41.8 | 815 | 11.3 | 5.0 | 3600±25% | 0.5 |

NI limit vs. AL-value (Typ.)

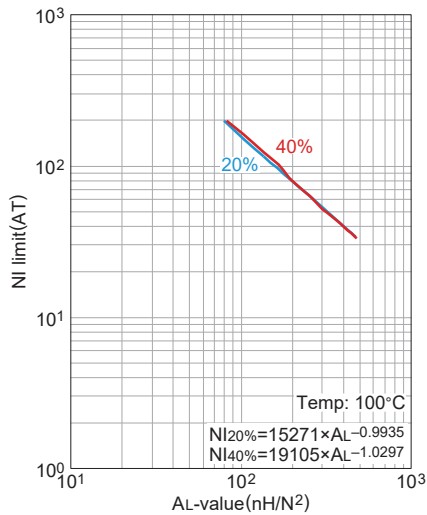

The 20% and 40% graph shows when a 20% and 40% drop from the initial AL-value has been made due to the DC superimposition.

AL-value vs. Air gap length (Typ.)

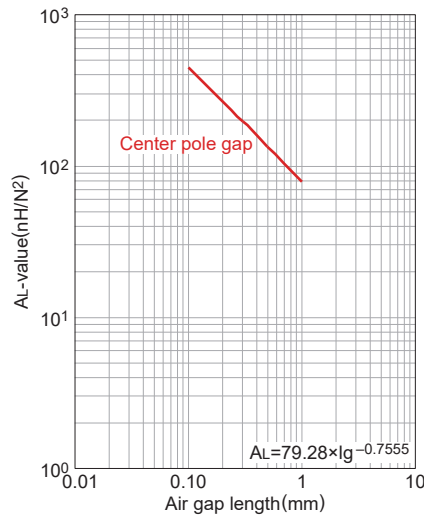

Measuring conditions
 • Coil : $\phi 0.18$ 2UEW 100Ts
 • Frequency : 1kHz
 • Current level : 0.5mA
 • Ambient temperature : 25°C

⚠ Please be sure to request delivery specifications that provide further details on the features and specifications of the products for proper and safe use. Please note that the contents may change without any prior notice due to reasons such as upgrading.

Mn-Zn Planar series Part No.: PC95PQI16/7.8Z-12

SHAPES AND DIMENSIONS

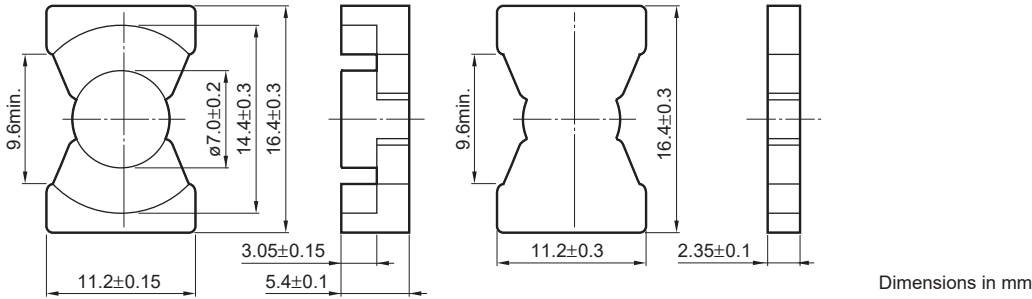

Dimensions in mm

| Effective parameter | | | | | | Electrical characteristics | | | | |
|---------------------------------------|--------------------------------|--------------------------------------|--------------------------------------|---------------------------------------|---------|---------------------------------------|----------------------------|------|------|-------|
| Core factor | Effective magnetic path length | Effective cross-sectional area | Effective core volume | Cross-sectional winding area of core | Weigh | AL-value * | Core loss | | | |
| C ₁ (mm ⁻¹) | ℓ _e (mm) | A _e (mm ²) | V _e (mm ³) | A _{cw} (mm ²) | (g/set) | (nH/N ²) 1kHz 0.5mA | (W)max. 100kHz 200mT | 25°C | 80°C | 120°C |
| 0.467 | 19.5 | 41.8 | 815 | 11.3 | 5.0 | 4910±25% | 0.45 | 0.35 | 0.45 | |

NI limit vs. AL-value (Typ.)

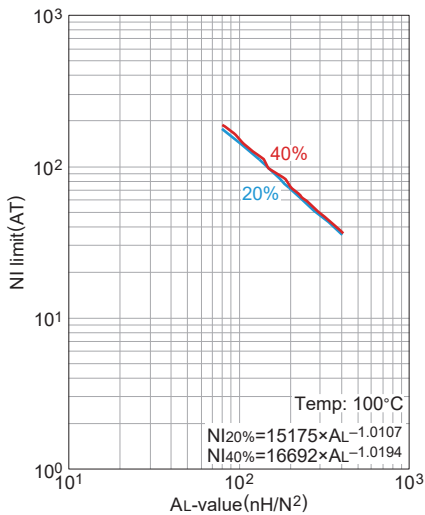

The 20% and 40% graph shows when a 20% and 40% drop from the initial AL-value has been made due to the DC superimposition.

AL-value vs. Air gap length (Typ.)

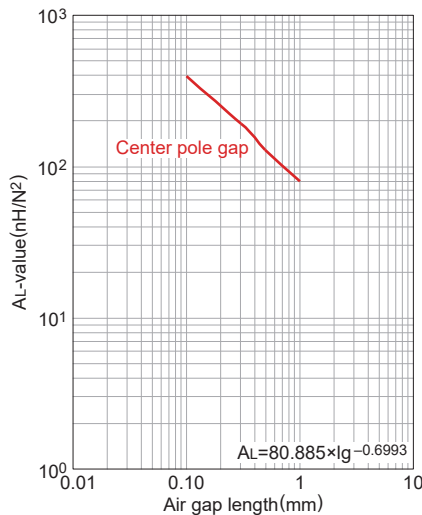

Measuring conditions

- Coil : ø0.18 2UEW 100Ts
- Frequency : 1kHz
- Current level : 0.5mA
- Ambient temperature : 25°C

⚠ Please be sure to request delivery specifications that provide further details on the features and specifications of the products for proper and safe use. Please note that the contents may change without any prior notice due to reasons such as upgrading.

Mn-Zn Planar series Part No.: PC90PQI20/9Z-12

SHAPES AND DIMENSIONS

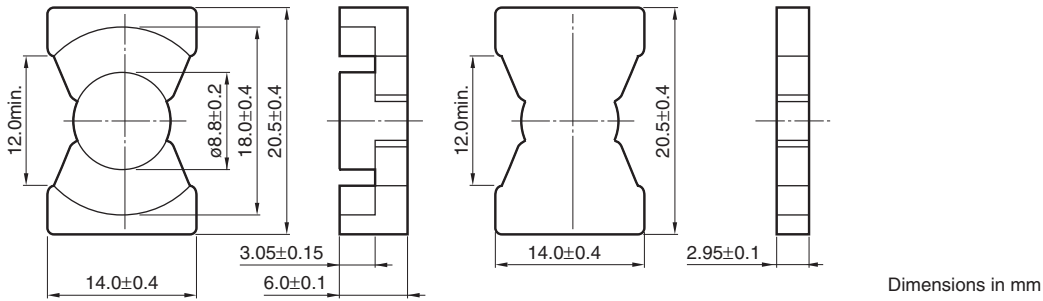

| Effective parameter | | | | | | Electrical characteristics | |
|------------------------------|--------------------------------|--------------------------------|-----------------------------|--------------------------------------|---------|---------------------------------------|-------------------------------------|
| Core factor | Effective magnetic path length | Effective cross-sectional area | Effective core volume | Cross-sectional winding area of core | Weight | AL-value * | Core loss |
| C_1 (mm ⁻¹) | ℓ_e (mm) | A_e (mm ²) | V_e (mm ³) | A_{cw} (mm ²) | (g/set) | (nH/N ²) 1kHz 0.5mA | (W)max. 100kHz 200mT 100°C |
| 0.346 | 22.9 | 66.0 | 1510 | 14.0 | 9.0 | 5200±25% | 0.8 |

NI limit vs. AL-value (Typ.)

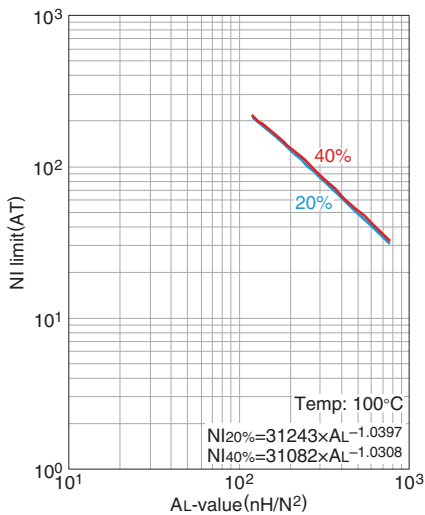

The 20% and 40% graph shows when a 20% and 40% drop from the initial AL-value has been made due to the DC superimposition.

AL-value vs. Air gap length (Typ.)

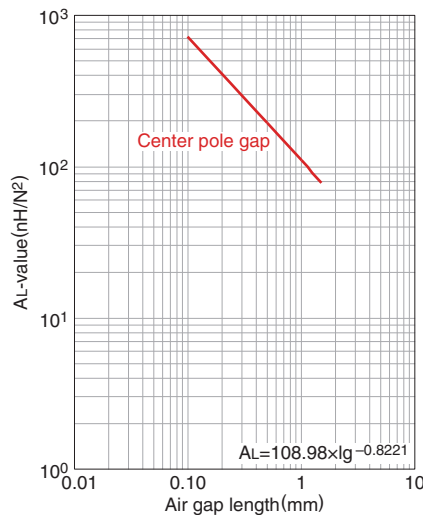

Measuring conditions
 • Coil : $\phi 0.18$ 2UEW 100Ts
 • Frequency : 1kHz
 • Current level : 0.5mA
 • Ambient temperature : 25°C

⚠ Please be sure to request delivery specifications that provide further details on the features and specifications of the products for proper and safe use. Please note that the contents may change without any prior notice due to reasons such as upgrading.

Mn-Zn Planar series **Part No.: PC95PQI20/9Z-12**

SHAPES AND DIMENSIONS

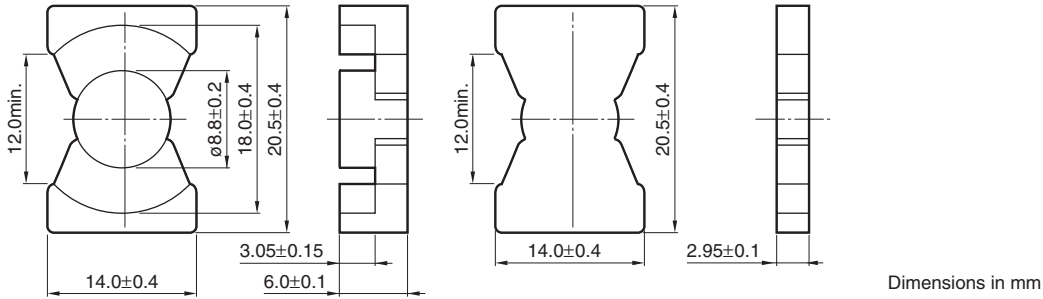

| Effective parameter | | | | | | Electrical characteristics | | | | |
|------------------------------|--------------------------------|--------------------------------|-----------------------------|--------------------------------------|---------|---------------------------------------|----------------------------|------|------|-------|
| Core factor | Effective magnetic path length | Effective cross-sectional area | Effective core volume | Cross-sectional winding area of core | Weight | AL-value * | Core loss | | | |
| C_1 (mm ⁻¹) | ℓ_e (mm) | A_e (mm ²) | V_e (mm ³) | A_{cw} (mm ²) | (g/set) | (nH/N ²) 1kHz 0.5mA | (W)max. 100kHz 200mT | 25°C | 80°C | 120°C |
| 0.346 | 22.9 | 66.0 | 1510 | 14.0 | 9.0 | 7070±25% | 0.75 | 0.65 | 0.75 | |

NI limit vs. AL-value (Typ.)

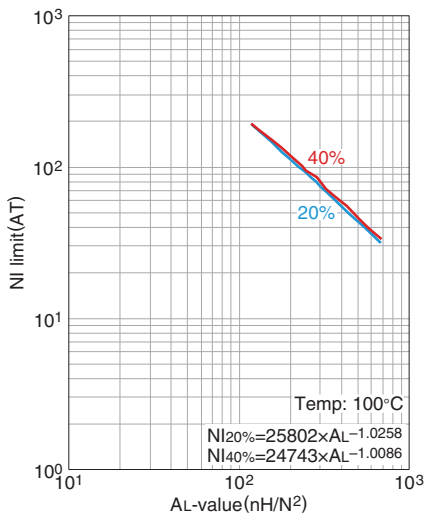

The 20% and 40% graph shows when a 20% and 40% drop from the initial AL-value has been made due to the DC superimposition.

AL-value vs. Air gap length (Typ.)

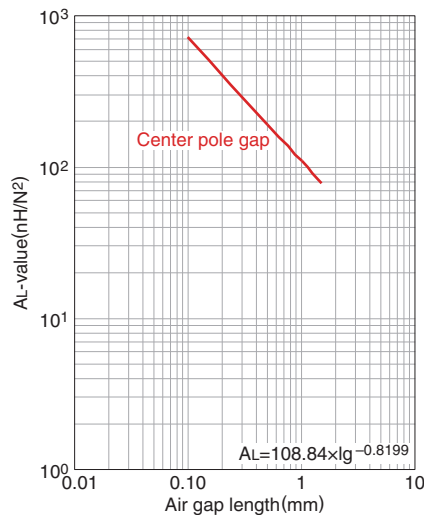

Measuring conditions
 • Coil : $\phi 0.18$ 2UEW 100Ts
 • Frequency : 1kHz
 • Current level : 0.5mA
 • Ambient temperature : 25°C

⚠ Please be sure to request delivery specifications that provide further details on the features and specifications of the products for proper and safe use. Please note that the contents may change without any prior notice due to reasons such as upgrading.

Mn-Zn Planar series Part No.: PC90PQI26/12Z-12

SHAPES AND DIMENSIONS

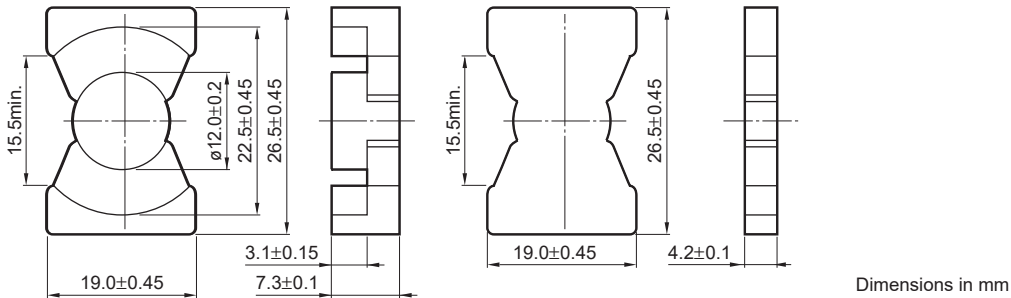

| Effective parameter | | | | | | Electrical characteristics | |
|---------------------------------------|--------------------------------|--------------------------------------|--------------------------------------|---------------------------------------|---------|---------------------------------------|-------------------------------------|
| Core factor | Effective magnetic path length | Effective cross-sectional area | Effective core volume | Cross-sectional winding area of core | Weight | AL-value * | Core loss |
| C ₁ (mm ⁻¹) | ℓ _e (mm) | A _e (mm ²) | V _e (mm ³) | A _{cw} (mm ²) | (g/set) | (nH/N ²) 1kHz 0.5mA | (W)max. 100kHz 200mT 100°C |
| 0.224 | 27.7 | 123 | 3410 | 16.3 | 21 | 8600±25% | 1.6 |

NI limit vs. AL-value (Typ.)

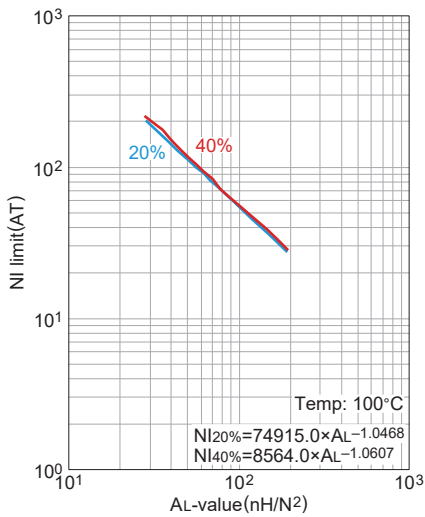

The 20% and 40% graph shows when a 20% and 40% drop from the initial AL-value has been made due to the DC superimposition.

AL-value vs. Air gap length (Typ.)

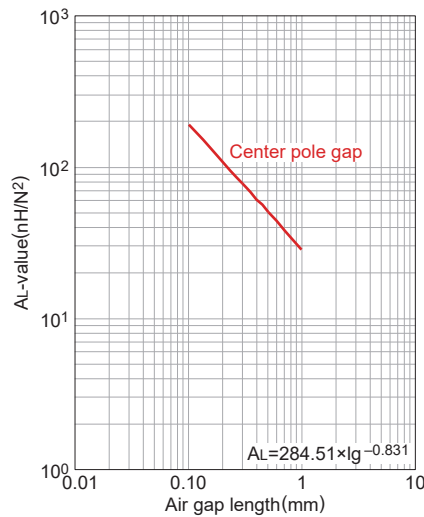

Measuring conditions
 • Coil : ø0.18 2UEW 100Ts
 • Frequency : 1kHz
 • Current level : 0.5mA
 • Ambient temperature : 25°C

⚠ Please be sure to request delivery specifications that provide further details on the features and specifications of the products for proper and safe use. Please note that the contents may change without any prior notice due to reasons such as upgrading.

Mn-Zn Planar series Part No.: PC95PQI26/12Z-12

SHAPES AND DIMENSIONS

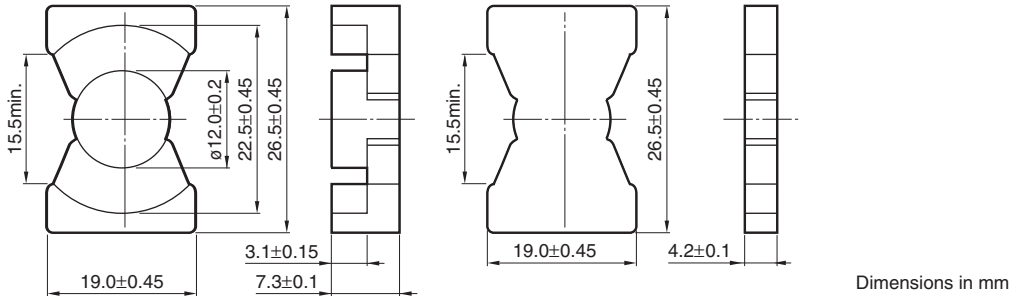

| Effective parameter | | | | | | Electrical characteristics | | | | |
|------------------------------|--------------------------------|--------------------------------|-----------------------------|--------------------------------------|---------|---------------------------------------|----------------------------|------|------|-------|
| Core factor | Effective magnetic path length | Effective cross-sectional area | Effective core volume | Cross-sectional winding area of core | Weight | AL-value * | Core loss | | | |
| C_1 (mm ⁻¹) | ℓ_e (mm) | A_e (mm ²) | V_e (mm ³) | A_{cw} (mm ²) | (g/set) | (nH/N ²) 1kHz 0.5mA | (W)max. 100kHz 200mT | 25°C | 80°C | 120°C |
| 0.224 | 27.7 | 123 | 3410 | 16.3 | 21 | 11950±25% | 1.5 | 1.4 | 1.5 | |

NI limit vs. AL-value (Typ.)

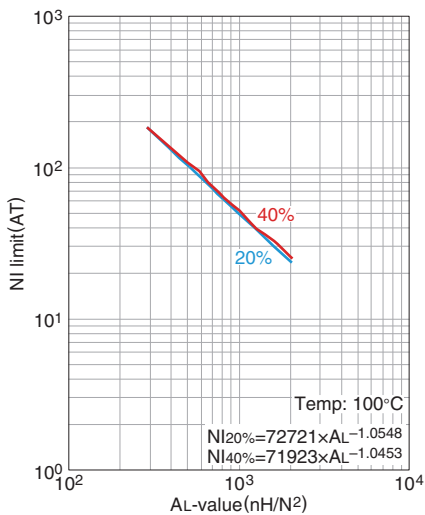

The 20% and 40% graph shows when a 20% and 40% drop from the initial AL-value has been made due to the DC superimposition.

AL-value vs. Air gap length (Typ.)

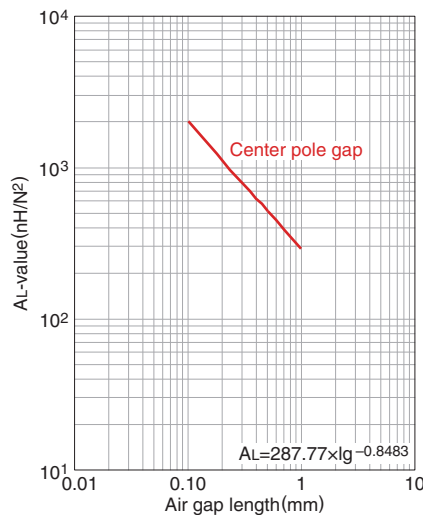

Measuring conditions
 • Coil : $\phi 0.18$ 2UEW 100Ts
 • Frequency : 1kHz
 • Current level : 0.5mA
 • Ambient temperature : 25°C

⚠ Please be sure to request delivery specifications that provide further details on the features and specifications of the products for proper and safe use. Please note that the contents may change without any prior notice due to reasons such as upgrading.

Mn-Zn EIR Cores

SHAPES AND DIMENSIONS

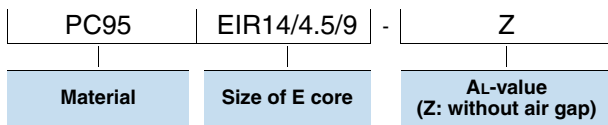
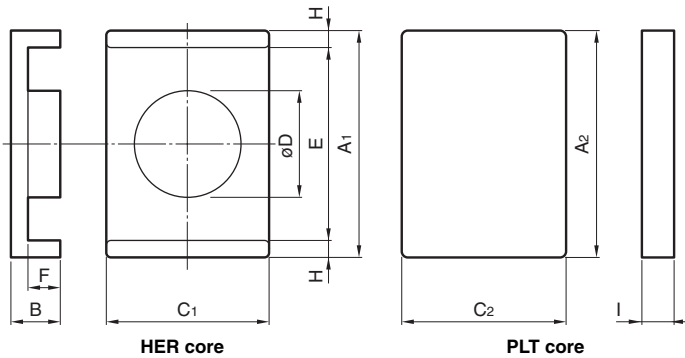
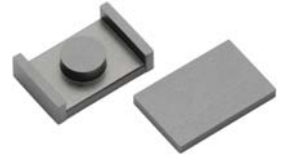

| Part No.(ELH+ELH) | Dimensions (mm) | | | | | | | | | |
|--------------------|-----------------|-----------|------------|-----------|------------|-----------|------|------------|------------|-----------|
| | A1 | B | C1 | øD | E | F | H | A2 | C2 | I |
| PC95EIR14/4.5/9-Z | 13.85±0.25 | 3.20±0.10 | 9.00±0.20 | 5.20±0.10 | 11.35±0.15 | 1.90±0.10 | 1.25 | 14.00±0.20 | 9.20±0.20 | 1.30±0.10 |
| PC90EIR14/4.5/9-Z | | | | | | | | | | |
| PC95EIR18/5/12-Z | 18.15±0.30 | 3.50±0.10 | 12.00±0.20 | 6.00±0.10 | 15.75±0.25 | 2.00±0.10 | 1.20 | 18.20±0.25 | 12.20±0.20 | 1.50±0.10 |
| PC90EIR18/5/12-Z | | | | | | | | | | |
| PC95EIR22/5.5/15-Z | 22.10±0.35 | 3.75±0.10 | 15.25±0.25 | 6.80±0.10 | 19.70±0.30 | 2.00±0.10 | 1.20 | 22.20±0.30 | 15.50±0.20 | 1.75±0.10 |
| PC90EIR22/5.5/15-Z | | | | | | | | | | |

| Part No.(HPQ+PQD) | Effective parameter | | | | | | | Electrical characteristics | |
|--------------------|-----------------------|---------------------------------------|---|--|--------------------------|------------------------|-----------|--|------------------|
| | Core factor | Effective magnetic path length ℓe(mm) | Effective cross-sectional area Ae(mm ²) | Effective core volume Ve(mm ³) | Amin. (mm ²) | Acw (mm ²) | Weigh (g) | AL-value | |
| | C1(mm ⁻¹) | | | | | | | (nH/N ²) 1kHz 0.5mA 100Ts | |
| PC95EIR14/4.5/9-Z | 0.679 | 15.4 | 22.7 | 349 | 21.2 | 5.84 | 2.0 | 2800±25% | 63±3% |
| PC90EIR14/4.5/9-Z | | | | | | | | 2050±25% | 100±5% 160±7% |
| PC95EIR18/5/12-Z | 0.601 | 19.7 | 32.8 | 645 | 28.3 | 9.75 | 3.8 | 3690±25% | 80±3% |
| PC90EIR18/5/12-Z | | | | | | | | 2500±25% | 125±5% 200±7% |
| PC95EIR22/5.5/15-Z | 0.505 | 23.2 | 46.1 | 1070 | 36.3 | 12.9 | 6.5 | 4150±25% | 80±3% |
| PC90EIR22/5.5/15-Z | | | | | | | | 3000±25% | 125±5% 200±7% |

⚠ Please be sure to request delivery specifications that provide further details on the features and specifications of the products for proper and safe use.
Please note that the contents may change without any prior notice due to reasons such as upgrading.

Mn-Zn Planar series Part No.: PC90EIR14/4.5/9-Z

SHAPES AND DIMENSIONS

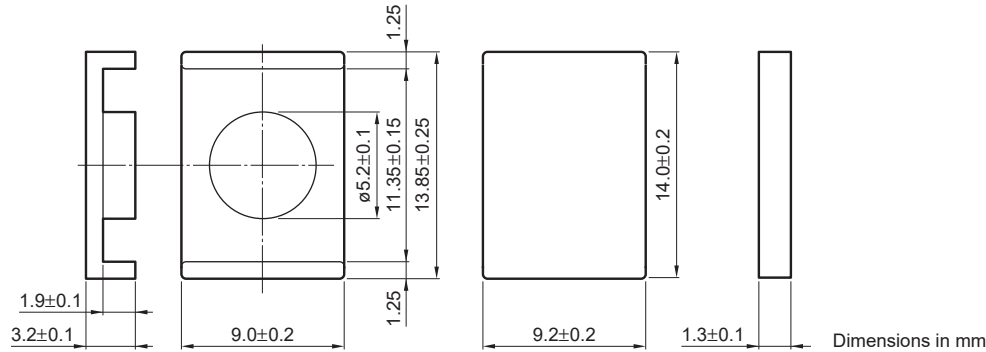

| Effective parameter | | | | | | Electrical characteristics | |
|---------------------------------------|--------------------------------|--------------------------------------|--------------------------------------|---------------------------------------|---------|---------------------------------------|-------------------------------------|
| Core factor | Effective magnetic path length | Effective cross-sectional area | Effective core volume | Cross-sectional winding area of core | Weight | AL-value * | Core loss |
| C ₁ (mm ⁻¹) | ℓ _e (mm) | A _e (mm ²) | V _e (mm ³) | A _{cw} (mm ²) | (g/set) | (nH/N ²) 1kHz 0.5mA | (W)max. 100kHz 200mT 100°C |
| 0.679 | 15.4 | 22.7 | 349 | 5.84 | 2.0 | 2050±25% | 0.3 |

NI limit vs. AL-value (Typ.)

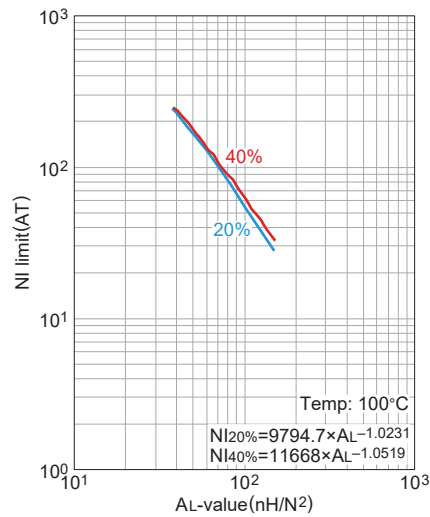

The 20% and 40% graph shows when a 20% and 40% drop from the initial AL-value has been made due to the DC superimposition.

AL-value vs. Air gap length (Typ.)

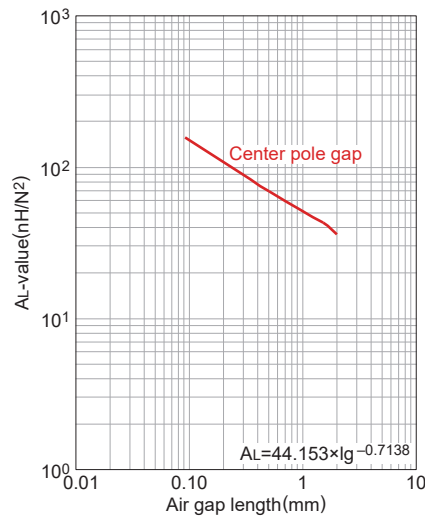

Measuring conditions
 • Coil : ø0.18 2UEW 100Ts
 • Frequency : 1kHz
 • Current level : 0.5mA
 • Ambient temperature : 25°C

⚠ Please be sure to request delivery specifications that provide further details on the features and specifications of the products for proper and safe use. Please note that the contents may change without any prior notice due to reasons such as upgrading.

Mn-Zn Planar series Part No.: PC90EIR18/5/12-Z

SHAPES AND DIMENSIONS

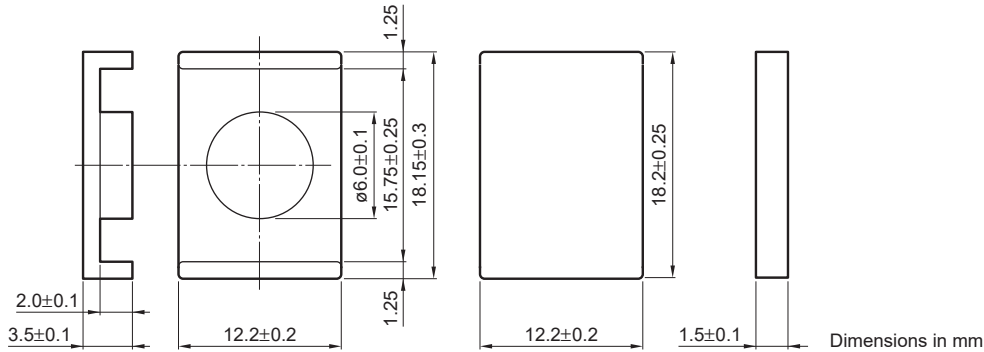

| Effective parameter | | | | | | Electrical characteristics | |
|---------------------------------------|--------------------------------|--------------------------------------|--------------------------------------|---------------------------------------|---------|---------------------------------------|-------------------------------------|
| Core factor | Effective magnetic path length | Effective cross-sectional area | Effective core volume | Cross-sectional winding area of core | Weight | AL-value * | Core loss |
| C ₁ (mm ⁻¹) | ℓ _e (mm) | A _e (mm ²) | V _e (mm ³) | A _{cw} (mm ²) | (g/set) | (nH/N ²) 1kHz 0.5mA | (W)max. 100kHz 200mT 100°C |
| 0.601 | 19.7 | 32.8 | 645 | 9.75 | 3.8 | 2500±25% | 0.45 |

NI limit vs. AL-value (Typ.)

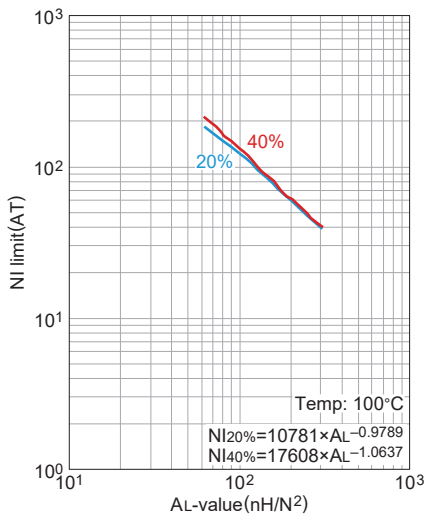

The 20% and 40% graph shows when a 20% and 40% drop from the initial AL-value has been made due to the DC superimposition.

AL-value vs. Air gap length (Typ.)

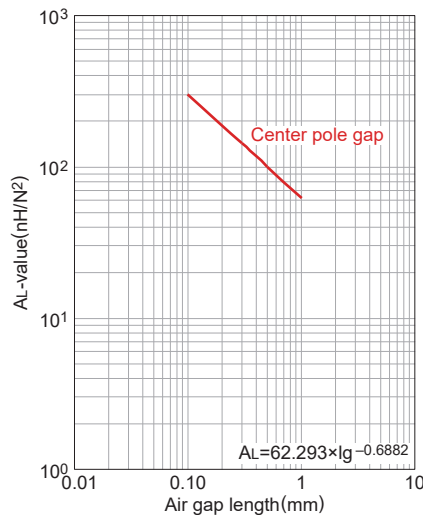

Measuring conditions
 • Coil : ø0.18 2UEW 100Ts
 • Frequency : 1kHz
 • Current level : 0.5mA
 • Ambient temperature : 25°C

⚠ Please be sure to request delivery specifications that provide further details on the features and specifications of the products for proper and safe use. Please note that the contents may change without any prior notice due to reasons such as upgrading.

Mn-Zn Planar series Part No.: PC95EIR18/5/12-Z

SHAPES AND DIMENSIONS

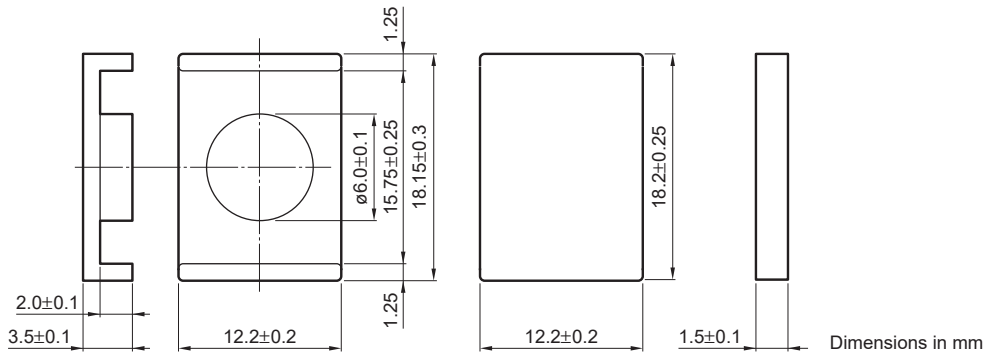

| Effective parameter | | | | | | Electrical characteristics | | | | |
|------------------------------|--------------------------------|--------------------------------|-----------------------------|--------------------------------------|---------|---------------------------------------|----------------------------|------|------|-------|
| Core factor | Effective magnetic path length | Effective cross-sectional area | Effective core volume | Cross-sectional winding area of core | Weight | AL-value * | Core loss | | | |
| C_1 (mm ⁻¹) | ℓ_e (mm) | A_e (mm ²) | V_e (mm ³) | A_{cw} (mm ²) | (g/set) | (nH/N ²) 1kHz 0.5mA | (W)max. 100kHz 200mT | 25°C | 80°C | 120°C |
| 0.601 | 19.7 | 32.8 | 645 | 9.75 | 3.8 | 3690±25% | 0.4 | 0.35 | 0.4 | |

NI limit vs. AL-value (Typ.)

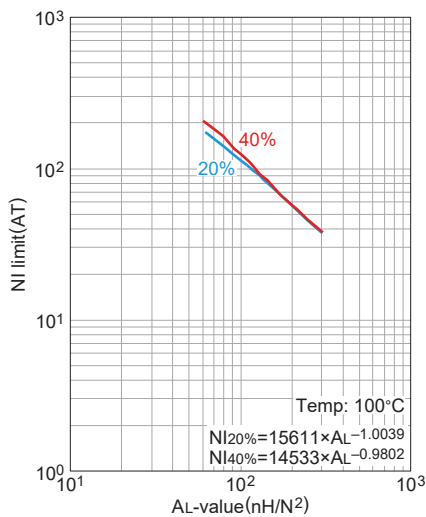

The 20% and 40% graph shows when a 20% and 40% drop from the initial AL-value has been made due to the DC superimposition.

AL-value vs. Air gap length (Typ.)

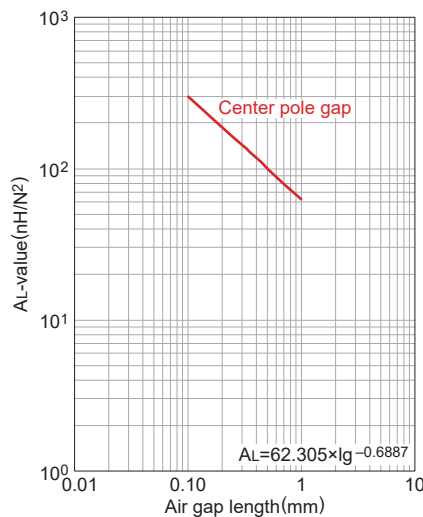

Measuring conditions
 • Coil : $\phi 0.18$ 2UEW 100Ts
 • Frequency : 1kHz
 • Current level : 0.5mA
 • Ambient temperature : 25°C

⚠ Please be sure to request delivery specifications that provide further details on the features and specifications of the products for proper and safe use. Please note that the contents may change without any prior notice due to reasons such as upgrading.

Mn-Zn ER Cores

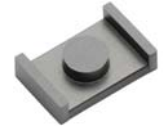

SHAPES AND DIMENSIONS

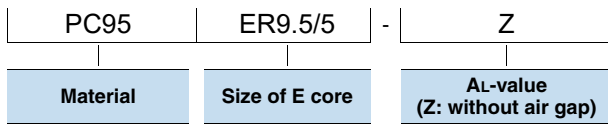
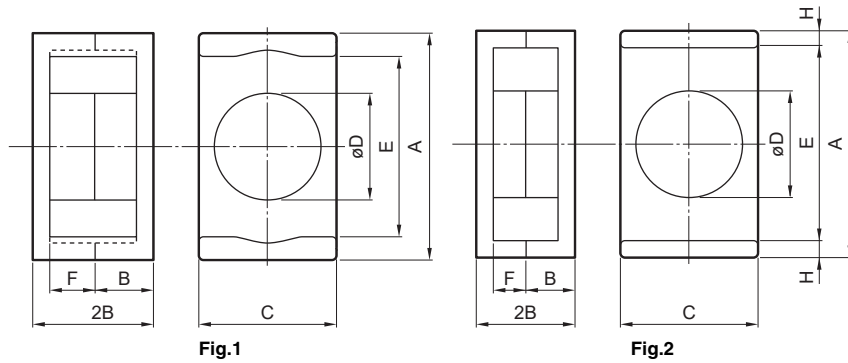

| Part No.(HER+HER) | Core | Dimensions (mm) | | | | | | |
|-------------------|-------|-------------------------------------|-----------------------------------|-----------------------------------|-------------------------------------|------------|------------------------------------|------|
| | | A | B | C | øD | E | F | H |
| PC95ER9.5/5-Z | Fig.1 | 9.5 ⁺⁰ _{-0.3} | 2.5 ⁺⁰ _{-0.1} | 5.0 ⁺⁰ _{-0.2} | 3.5 ⁺⁰ _{-0.2} | 7.0min. | 1.6 ^{+0.15} ₋₀ | — |
| PC90ER9.5/5-Z | | | | | | | | |
| PC95ER11/5-Z | Fig.1 | 11.0 ⁺⁰ _{-0.35} | 2.5 ⁺⁰ _{-0.1} | 6.0 ⁺⁰ _{-0.2} | 4.25 ⁺⁰ _{-0.25} | 7.9min. | 1.5 ^{+0.15} ₋₀ | — |
| PC90ER11/5-Z | | | | | | | | |
| PC95ER14/4.5/9-Z | Fig.2 | 13.85±0.25 | 2.25±0.10 | 9.00±0.20 | 5.20±0.10 | 11.35±0.15 | 0.95±0.10 | 1.25 |
| PC90ER14/4.5/9-Z | | | | | | | | |
| PC95ER14.5/6-Z | Fig.2 | 14.5±0.2 | 3.0 ⁺⁰ _{-0.1} | 6.7±0.1 | 4.7±0.1 | 11.8±0.2 | 1.65±0.1 | 1.35 |
| PC90ER14.5/6-Z | | | | | | | | |
| PC95ER18/5/12-Z | Fig.2 | 18.15±0.30 | 2.50±0.10 | 12.00±0.20 | 6.00±0.10 | 15.75±0.25 | 1.00±0.10 | 1.20 |
| PC90ER18/5/12-Z | | | | | | | | |
| PC95ER22/5.5/15-Z | Fig.2 | 22.10±0.35 | 2.75±0.10 | 15.25±0.25 | 6.80±0.10 | 19.70±0.30 | 1.00±0.10 | 1.20 |
| PC90ER22/5.5/15-Z | | | | | | | | |
| PC95ER25/5.5/18-Z | Fig.2 | 25.30±0.40 | 2.75±0.10 | 18.00±0.40 | 7.00±0.15 | 22.90±0.40 | 1.00±0.10 | 1.20 |
| PC90ER25/5.5/18-Z | | | | | | | | |

| Part No.(HER+HER) | Effective parameter | | | | | | | Electrical characteristics | |
|-------------------|------------------------------------|--------------------------------|-----------------------------------|-----------------------------------|--------------------|--------------------|-------|----------------------------|--------------|
| | Core factor | Effective magnetic path length | Effective cross-sectional area | Effective core volume | Amin. | Acw | Weigh | AL-value | |
| | C _i (mm ⁻¹) | ℓ _e (mm) | A _e (mm ²) | V _e (mm ³) | (mm ²) | (mm ²) | (g) | Without air gap | With air gap |
| PC95ER9.5/5-Z | 1.67 | 14.2 | 8.47 | 120 | 7.6 | 7.07 | 0.7 | 1190±25% | 63±5% |
| PC90ER9.5/5-Z | | | | | | | | 610min. | 100±7% |
| PC95ER11/5-Z | 1.23 | 14.7 | 11.9 | 174 | 10.3 | 7.44 | 1.1 | 1680±25% | 63±5% |
| PC90ER11/5-Z | | | | | | | | 1300±25% | 100±7% |
| PC95ER14/4.5/9-Z | 0.679 | 15.4 | 22.7 | 349 | 21.2 | 5.84 | 2.0 | 2550±25% | 63±3% |
| PC90ER14/4.5/9-Z | | | | | | | | 2100±25% | 100±5% |
| PC95ER14.5/6-Z | 1.08 | 19.0 | 17.6 | 333 | 17.3 | 8.42 | 2.0 | 1880±25% | 100±5% |
| PC90ER14.5/6-Z | | | | | | | | 1300±25% | 160±7% |
| PC95ER18/5/12-Z | 0.601 | 19.7 | 32.8 | 645 | 28.3 | 9.75 | 3.8 | 3500±25% | 80±3% |
| PC90ER18/5/12-Z | | | | | | | | 2900±25% | 125±5% |
| PC95ER22/5.5/15-Z | 0.505 | 23.2 | 46.1 | 1070 | 36.3 | 12.9 | 6.5 | 4300±25% | 80±3% |
| PC90ER22/5.5/15-Z | | | | | | | | 3200±25% | 125±5% |
| PC95ER25/5.5/18-Z | 0.486 | 26.1 | 53.7 | 1400 | 38.5 | 15.9 | 8.5 | 4400±25% | 80±3% |
| PC90ER25/5.5/18-Z | | | | | | | | 3400±25% | 125±3% |

⚠ Please be sure to request delivery specifications that provide further details on the features and specifications of the products for proper and safe use.
Please note that the contents may change without any prior notice due to reasons such as upgrading.

Mn-Zn Planar series **Part No.: PC90ER9.5/5-Z**

■ SHAPES AND DIMENSIONS

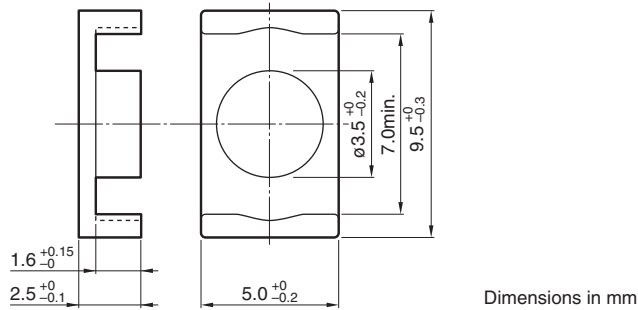

| Effective parameter | | | | | | Electrical characteristics | |
|---------------------------------------|--------------------------------|--------------------------------------|--------------------------------------|---------------------------------------|---------|---------------------------------------|-------------------------------------|
| Core factor | Effective magnetic path length | Effective cross-sectional area | Effective core volume | Cross-sectional winding area of core | Weight | AL-value * | Core loss |
| C ₁ (mm ⁻¹) | ℓ _e (mm) | A _e (mm ²) | V _e (mm ³) | A _{cw} (mm ²) | (g/set) | (nH/N ²) 1kHz 0.5mA | (W)max. 100kHz 200mT 100°C |
| 1.67 | 14.2 | 8.47 | 120 | 7.07 | 0.7 | 610min. | 0.1 |

NI limit vs. AL-value (Typ.)

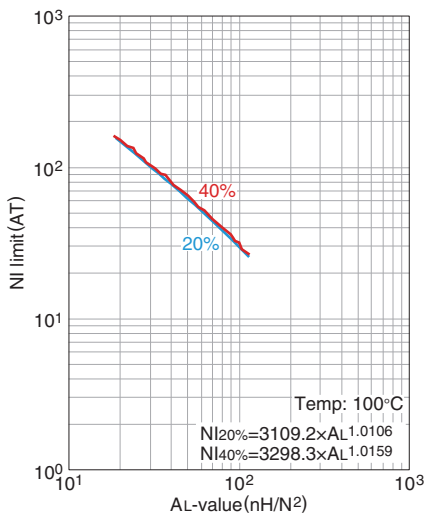

The 20% and 40% graph shows when a 20% and 40% drop from the initial AL-value has been made due to the DC superimposition.

AL-value vs. Air gap length (Typ.)

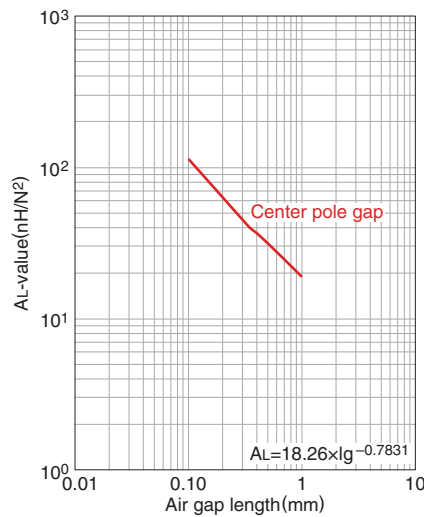

Measuring conditions
 • Coil : $\phi 0.18$ 2UEW 100Ts
 • Frequency : 1kHz
 • Current level : 0.5mA
 • Ambient temperature : 25°C

⚠ Please be sure to request delivery specifications that provide further details on the features and specifications of the products for proper and safe use. Please note that the contents may change without any prior notice due to reasons such as upgrading.

Mn-Zn Planar series Part No.: PC95ER9.5/5-Z

SHAPES AND DIMENSIONS

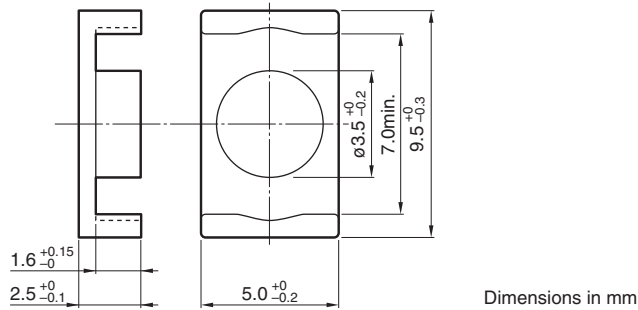

| Effective parameter | | | | | | Electrical characteristics | | | | |
|---------------------------------------|--------------------------------|--------------------------------------|--------------------------------------|---------------------------------------|---------|---------------------------------------|----------------------------|------|------|-------|
| Core factor | Effective magnetic path length | Effective cross-sectional area | Effective core volume | Cross-sectional winding area of core | Weight | AL-value * | Core loss | | | |
| C ₁ (mm ⁻¹) | ℓ _e (mm) | A _e (mm ²) | V _e (mm ³) | A _{cw} (mm ²) | (g/set) | (nH/N ²) 1kHz 0.5mA | (W)max. 100kHz 200mT | 25°C | 80°C | 120°C |
| 1.67 | 14.2 | 8.47 | 120 | 7.07 | 0.7 | 1190±25% | 0.1 | 0.09 | 0.1 | |

NI limit vs. AL-value (Typ.)

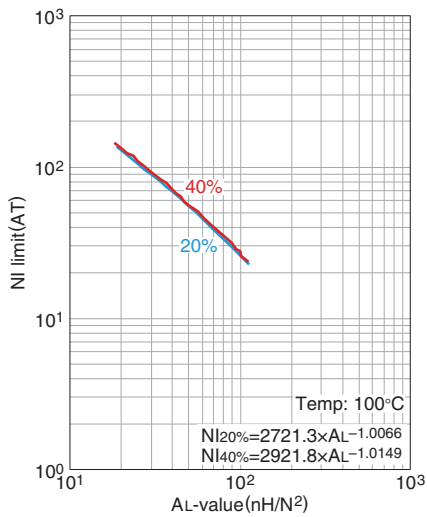

The 20% and 40% graph shows when a 20% and 40% drop from the initial AL-value has been made due to the DC superimposition.

AL-value vs. Air gap length (Typ.)

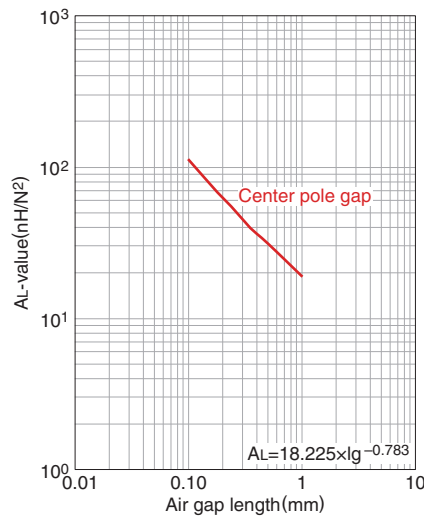

Measuring conditions

- Coil : ø0.18 2UEW 100Ts
- Frequency : 1kHz
- Current level : 0.5mA
- Ambient temperature : 25°C

⚠ Please be sure to request delivery specifications that provide further details on the features and specifications of the products for proper and safe use. Please note that the contents may change without any prior notice due to reasons such as upgrading.

Mn-Zn Planar series Part No.: PC90ER14/4.5/9-Z

SHAPES AND DIMENSIONS

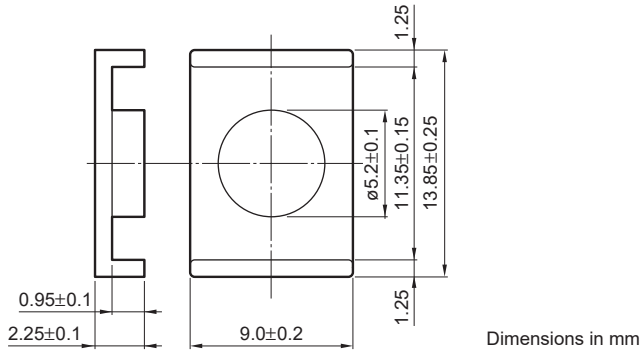

| Effective parameter | | | | | | Electrical characteristics | |
|---------------------------------------|--------------------------------|--------------------------------------|--------------------------------------|---------------------------------------|---------|---------------------------------------|-------------------------------------|
| Core factor | Effective magnetic path length | Effective cross-sectional area | Effective core volume | Cross-sectional winding area of core | Weigh | AL-value * | Core loss |
| C ₁ (mm ⁻¹) | ℓ _e (mm) | A _e (mm ²) | V _e (mm ³) | A _{cw} (mm ²) | (g/set) | (nH/N ²) 1kHz 0.5mA | (W)max. 100kHz 200mT 100°C |
| 0.679 | 15.4 | 22.7 | 349 | 5.84 | 2.0 | 2100±25% | 0.3 |

NI limit vs. AL-value (Typ.)

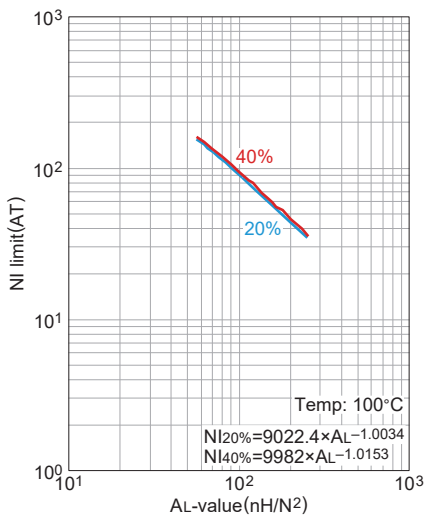

The 20% and 40% graph shows when a 20% and 40% drop from the initial AL-value has been made due to the DC superimposition.

AL-value vs. Air gap length (Typ.)

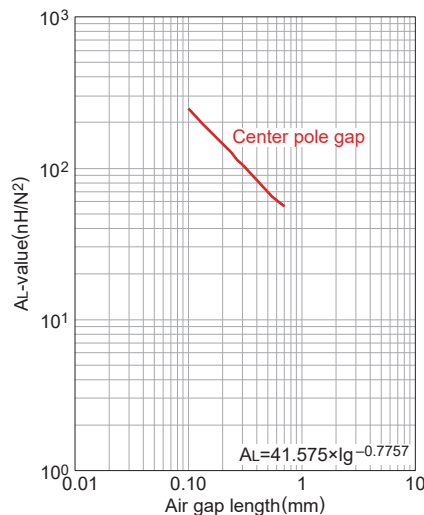

Measuring conditions

- Coil : $\varnothing 0.18$ 2UEW 100Ts
- Frequency : 1kHz
- Current level : 0.5mA
- Ambient temperature : 25°C

⚠ Please be sure to request delivery specifications that provide further details on the features and specifications of the products for proper and safe use. Please note that the contents may change without any prior notice due to reasons such as upgrading.

Mn-Zn Planar series Part No.: PC95ER14/4.5/9-Z

SHAPES AND DIMENSIONS

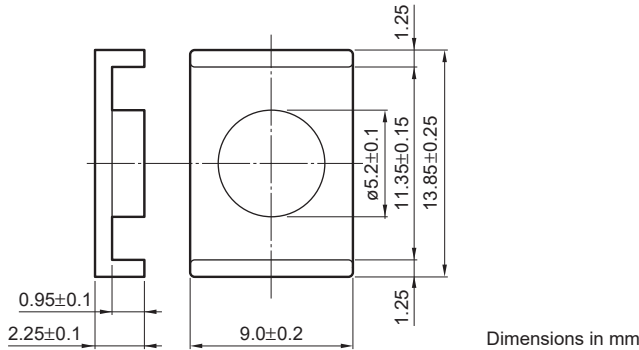

| Effective parameter | | | | | | Electrical characteristics | | | | |
|---------------------------------------|--------------------------------|--------------------------------------|--------------------------------------|---------------------------------------|---------|---------------------------------------|--|----------------------------|------|-------|
| Core factor | Effective magnetic path length | Effective cross-sectional area | Effective core volume | Cross-sectional winding area of core | Weigh | AL-value * | | Core loss | | |
| C ₁ (mm ⁻¹) | ℓ _e (mm) | A _e (mm ²) | V _e (mm ³) | A _{cw} (mm ²) | (g/set) | (nH/N ²) 1kHz 0.5mA | | (W)max. 100kHz 200mT | | |
| | | | | | | | | 25°C | 80°C | 120°C |
| 0.679 | 15.4 | 22.7 | 349 | 5.84 | 2.0 | 2550±25% | | 0.25 | 0.2 | 0.25 |

NI limit vs. AL-value (Typ.)

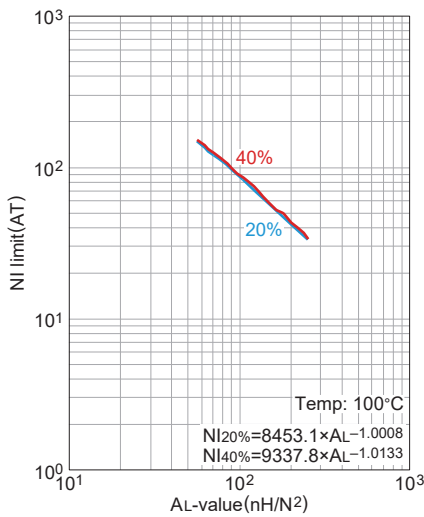

The 20% and 40% graph shows when a 20% and 40% drop from the initial AL-value has been made due to the DC superimposition.

AL-value vs. Air gap length (Typ.)

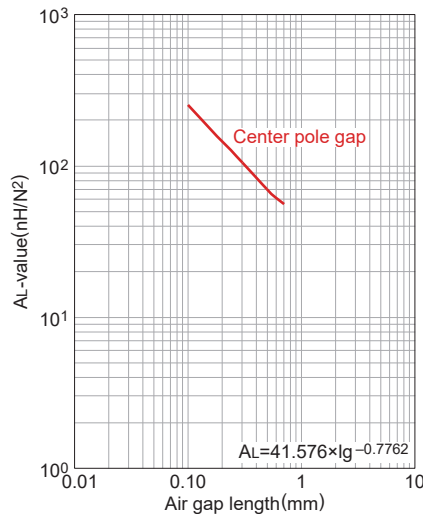

Measuring conditions
 • Coil : ø0.18 2UEW 100Ts
 • Frequency : 1kHz
 • Current level : 0.5mA
 • Ambient temperature : 25°C

⚠ Please be sure to request delivery specifications that provide further details on the features and specifications of the products for proper and safe use. Please note that the contents may change without any prior notice due to reasons such as upgrading.

Mn-Zn Planar series Part No.: PC95ER14.5/6-Z

SHAPES AND DIMENSIONS

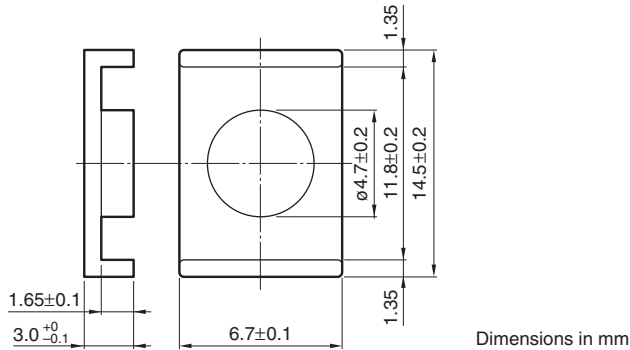

| Effective parameter | | | | | | Electrical characteristics | | | | |
|---------------------------------------|--------------------------------|--------------------------------------|--------------------------------------|---------------------------------------|---------|---------------------------------------|----------------------------|------|------|-------|
| Core factor | Effective magnetic path length | Effective cross-sectional area | Effective core volume | Cross-sectional winding area of core | Weigh | AL-value * | Core loss | | | |
| C ₁ (mm ⁻¹) | ℓ _e (mm) | A _e (mm ²) | V _e (mm ³) | A _{cw} (mm ²) | (g/set) | (nH/N ²) 1kHz 0.5mA | (W)max. 100kHz 200mT | 25°C | 80°C | 120°C |
| 1.08 | 19.0 | 17.6 | 333 | 8.42 | 2.0 | 3500±25% | 0.3 | 0.28 | 0.3 | |

NI limit vs. AL-value (Typ.)

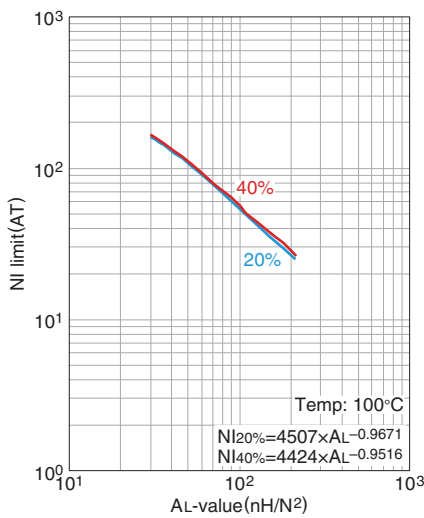

The 20% and 40% graph shows when a 20% and 40% drop from the initial AL-value has been made due to the DC superimposition.

AL-value vs. Air gap length (Typ.)

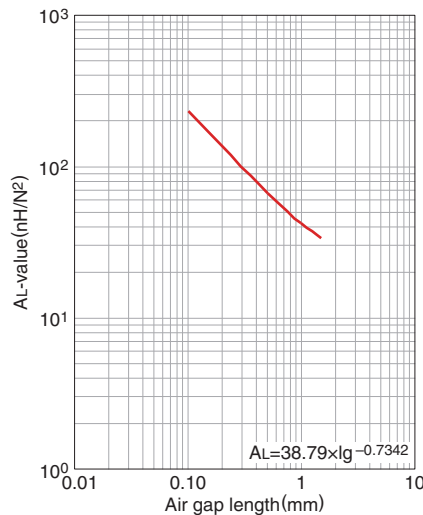

Measuring conditions
 • Coil : ø0.18 2UEW 100Ts
 • Frequency : 1kHz
 • Current level : 0.5mA
 • Ambient temperature : 25°C

⚠ Please be sure to request delivery specifications that provide further details on the features and specifications of the products for proper and safe use. Please note that the contents may change without any prior notice due to reasons such as upgrading.

Mn-Zn EI Cores

SHAPES AND DIMENSIONS

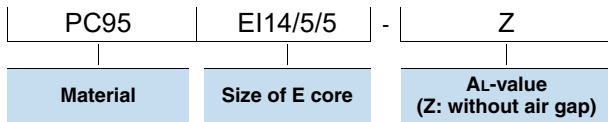
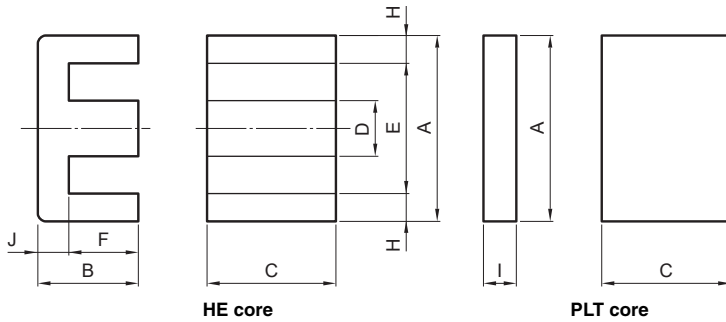

| Part No.(HE+PLT) | Dimensions (mm) | | | | | | | | | |
|------------------|-----------------|-----------|------------|-----------|------------|-----------|------|-----------|------|--|
| | A | B | C | D | E | F | H | I | J | |
| PC95EI14/5/5-Z | 14.00±0.30 | 3.50±0.10 | 5.00±0.10 | 3.00±0.10 | 11.00±0.25 | 2.00±0.10 | 1.50 | 1.50±0.05 | 1.50 | |
| PC90EI14/5/5-Z | | | | | | | | | | |
| PC95EI18/6/10-Z | 18.00±0.35 | 4.00±0.10 | 10.00±0.20 | 4.00±0.10 | 14.00±0.30 | 2.00±0.10 | 2.00 | 2.00±0.05 | 2.00 | |
| PC90EI18/6/10-Z | | | | | | | | | | |
| PC95EI22/8/16-Z | 21.80±0.40 | 5.70±0.10 | 15.80±0.30 | 5.00±0.10 | 16.80±0.40 | 3.20±0.10 | 2.50 | 2.50±0.05 | 2.50 | |
| PC90EI22/8/16-Z | | | | | | | | | | |

| Part No.(HER+HER) | Effective parameter | | | | | | | Electrical characteristics | |
|-------------------|---------------------------|--|---|--|--------------------------------|-----------------------------|-----------|--|--------|
| | Core factor | Effective magnetic path length ℓ_e (mm) | Effective cross-sectional area A_e (mm ²) | Effective core volume V_e (mm ³) | A_{min} . (mm ²) | A_{cw} (mm ²) | Weigh (g) | AL-value | |
| | C_1 (mm ⁻¹) | | | | | | | (nH/N ²) 1kHz 0.5mA 100Ts | |
| PC95EI14/5/5-Z | 1.11 | 16.7 | 15.0 | 251 | 15.0 | 8.00 | 1.3 | 1550±25% | 63±3% |
| PC90EI14/5/5-Z | | | | | | | | 1200±25% | 100±5% |
| PC95EI18/6/10-Z | 0.507 | 20.3 | 40.0 | 811 | 40.0 | 10.0 | 4.4 | 4720±25% | 100±3% |
| PC90EI18/6/10-Z | | | | | | | | 3100±25% | 160±3% |
| PC95EI22/8/16-Z | 0.330 | 26.1 | 79.0 | 2060 | 79.0 | 18.9 | 11 | 8010±25% | 160±3% |
| PC90EI22/8/16-Z | | | | | | | | 5300±25% | 250±3% |

⚠ Please be sure to request delivery specifications that provide further details on the features and specifications of the products for proper and safe use. Please note that the contents may change without any prior notice due to reasons such as upgrading.

Mn-Zn Planar series Part No.: PC90E14/5/5-Z

SHAPES AND DIMENSIONS

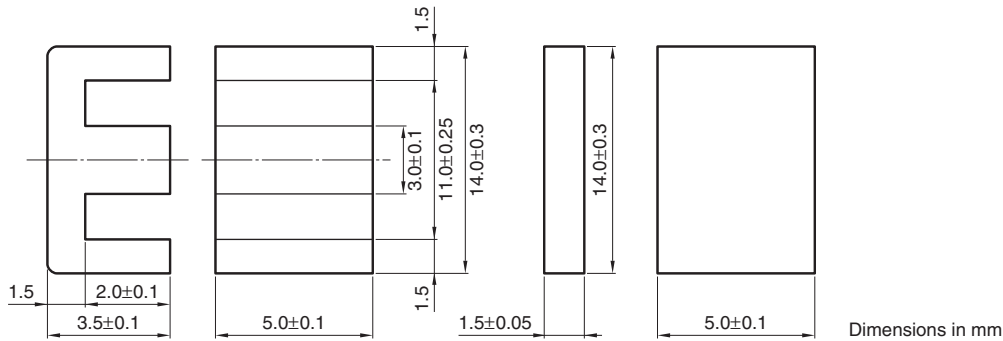

| Effective parameter | | | | | | Electrical characteristics | |
|---------------------------------------|--------------------------------|--------------------------------------|--------------------------------------|---------------------------------------|---------|---------------------------------------|-------------------------------------|
| Core factor | Effective magnetic path length | Effective cross-sectional area | Effective core volume | Cross-sectional winding area of core | Weigh | AL-value * | Core loss |
| C ₁ (mm ⁻¹) | ℓ _e (mm) | A _e (mm ²) | V _e (mm ³) | A _{cw} (mm ²) | (g/set) | (nH/N ²) 1kHz 0.5mA | (W)max. 100kHz 200mT 100°C |
| 1.11 | 16.7 | 15.0 | 251 | 8.0 | 1.3 | 1200±25% | 0.3 |

NI limit vs. AL-value (Typ.)

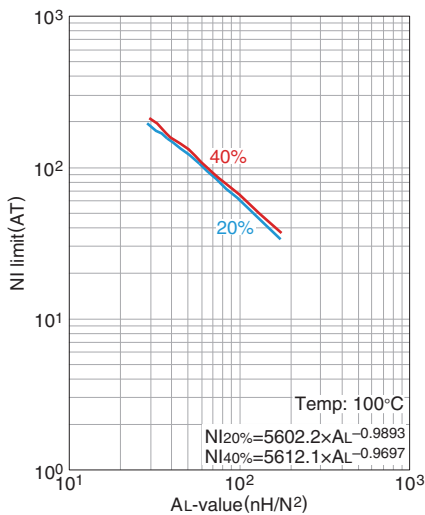

The 20% and 40% graph shows when a 20% and 40% drop from the initial AL-value has been made due to the DC superimposition.

AL-value vs. Air gap length (Typ.)

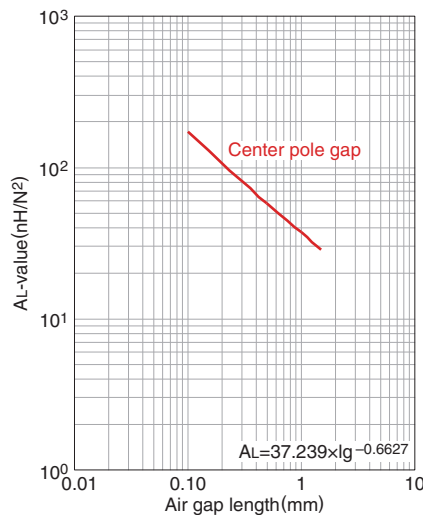

Measuring conditions
 • Coil : ø0.18 2UEW 100Ts
 • Frequency : 1kHz
 • Current level : 0.5mA
 • Ambient temperature : 25°C

⚠ Please be sure to request delivery specifications that provide further details on the features and specifications of the products for proper and safe use. Please note that the contents may change without any prior notice due to reasons such as upgrading.

Mn-Zn Planar series Part No.: PC95E14/5/5-Z

SHAPES AND DIMENSIONS

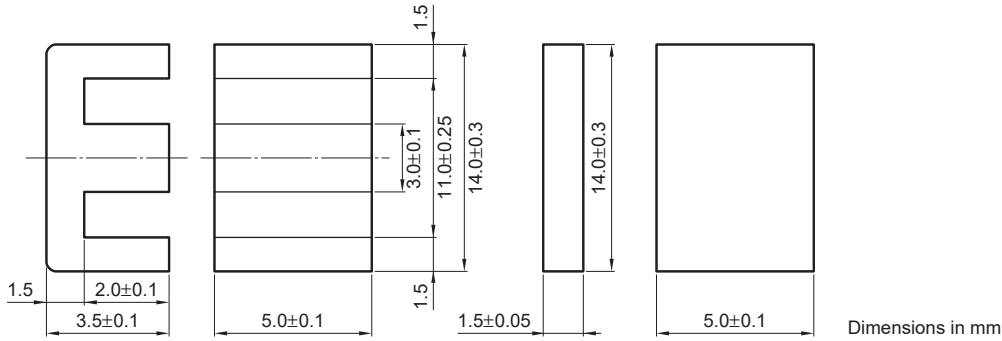

| Effective parameter | | | | | | Electrical characteristics | | | | |
|------------------------------|--------------------------------|--------------------------------|-----------------------------|--------------------------------------|---------|---------------------------------------|----------------------------|------|------|-------|
| Core factor | Effective magnetic path length | Effective cross-sectional area | Effective core volume | Cross-sectional winding area of core | Weight | AL-value * | Core loss | | | |
| C_1 (mm ⁻¹) | ℓ_e (mm) | A_e (mm ²) | V_e (mm ³) | A_{cw} (mm ²) | (g/set) | (nH/N ²) 1kHz 0.5mA | (W)max. 100kHz 200mT | 25°C | 80°C | 120°C |
| 1.11 | 16.7 | 15.0 | 251 | 8.0 | 1.3 | 1550±25% | 0.3 | 0.25 | 0.3 | |

NI limit vs. AL-value (Typ.)

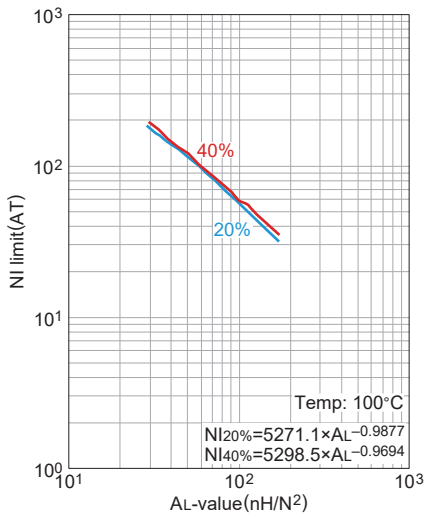

The 20% and 40% graph shows when a 20% and 40% drop from the initial AL-value has been made due to the DC superimposition.

AL-value vs. Air gap length (Typ.)

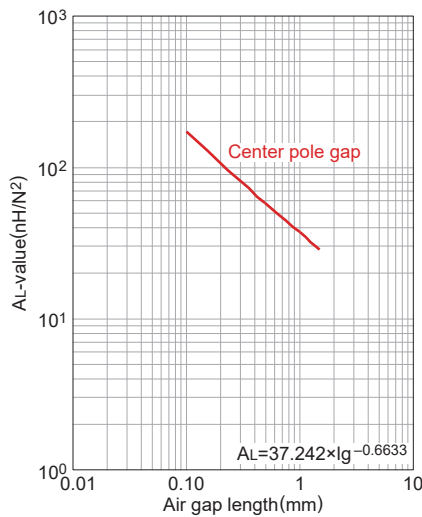

Measuring conditions
 • Coil : ϕ 0.18 2UEW 100Ts
 • Frequency : 1kHz
 • Current level : 0.5mA
 • Ambient temperature : 25°C

⚠ Please be sure to request delivery specifications that provide further details on the features and specifications of the products for proper and safe use. Please note that the contents may change without any prior notice due to reasons such as upgrading.

Mn-Zn

Ferrite Cores for Switching Power Supplies

PQ series

 **REMINDERS FOR USING THESE PRODUCTS**

Please be sure to read this manual thoroughly before using the products.

The products listed on this catalog are intended for use in general electronic equipment (AV equipment, telecommunications equipment, home appliances, amusement equipment, computer equipment, personal equipment, office equipment, measurement equipment, industrial robots) under a normal operation and use condition.

The products are not designed or warranted to meet the requirements of the applications listed below, whose performance and/or quality require a more stringent level of safety or reliability, or whose failure, malfunction or trouble could cause serious damage to society, person or property.

When using the products for specific purposes, please first make confirmations in areas such as safety, reliability, and quality.

Please understand that we are not in a position to be held responsible for any damage or the like caused by any use exceeding the range or conditions of this specification sheet or by any use in the specific applications.

- | | |
|---|--|
| (1) Aerospace/Aviation equipment | (8) Public information-processing equipment |
| (2) Transportation equipment (electric trains, ships, etc.) | (9) Military equipment |
| (3) Medical equipment | (10) Electric heating apparatus, burning equipment |
| (4) Power-generation control equipment | (11) Disaster prevention/crime prevention equipment |
| (5) Atomic energy-related equipment | (12) Safety equipment |
| (6) Seabed equipment | (13) Other applications that are not considered general-purpose applications |
| (7) Transportation control equipment | |

When using this product in general-purpose standard applications, you are kindly requested to take into consideration securing protection circuit/equipment or providing backup circuits, etc to ensure higher safety.

Ferrite Core for Switching Power Supplies

Product compatible with RoHS directive
Halogen-free

Overview of the PQ Series

FEATURES

- TDK's original shapes
- The PQ Core occupies a smaller mounted area, as a transformer, compared to the E-core and EER-Core

APPLICATION

Transformers and coils for Switched-mode power supplies (High Mounting Density, Low Profile)

PART NUMBER CONSTRUCTION

| PC47 | PQ20/16 | Z | - | 2 | 2 |
|----------|-----------------|----------------------------------|---|-------------------|---------------------|
| Material | Size of PQ core | AL-value (Z: without air gap) | | Type | Number of lead slot |
| PC47 | PQ20/16 | | | 1 Without air gap | |
| PC90 | PQ20/20 | | | 2 With air gap | |
| PC95 | PQ26/20 | | | | |
| | PQ26/25 | | | | |
| | PQ32/20 | | | | |
| | PQ32/30 | | | | |
| | PQ35/35 | | | | |
| | PQ40/40 | | | | |
| | PQ50/50 | | | | |

RANGE OF USE AND STORAGE TEMPERATURE

| Temperature range | |
|-------------------------------|-----------------------------|
| Operating temperature (°C) | Storage temperature (°C) |
| -30 to +105 | -30 to +85 |

- RoHS Directive Compliant Product: See the following for more details related to RoHS Directive compliant products. <http://www.tdk.co.jp/rohs/>
- Halogen-free: Indicates that Cl content is less than 900ppm, Br content is less than 900ppm, and that the total Cl and Br content is less than 1500ppm.

• All specifications are subject to change without notice.

Mn-Zn PQ Cores



SHAPES AND DIMENSIONS

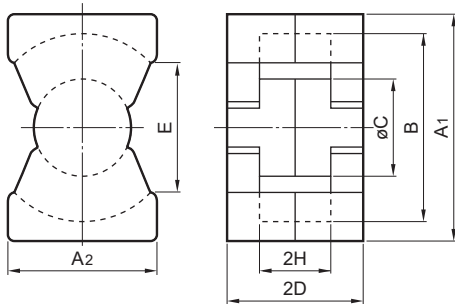

| | | | | | |
|-----------------|------------------------|--|---|-------------------|----------------------------|
| PC47 | PQ20/16 | Z | - | 1 | 2 |
| Material | Size of PQ core | AL-value (Z: without air gap) | | Type | Number of lead slot |
| | | | | 1 Without air gap | |
| | | | | 2 With air gap | |

| Part No. | Dimensions (mm) | | | | | | |
|---|-----------------|-----------|-----------|------------|------------|--------|----------|
| | A1 | A2 | B | øC | 2D | E min. | 2H |
| PC47PQ20/16Z-12 PC90PQ20/16Z-12 PC95PQ20/16Z-12 | 20.5±0.4 | 14.0±0.4 | 18.0±0.4 | 8.8±0.2 | 16.2±0.2 | 12.0 | 10.3±0.3 |
| PC47PQ20/20Z-12 PC90PQ20/20Z-12 PC95PQ20/20Z-12 | 20.5±0.4 | 14.0±0.4 | 18.0±0.4 | 8.8±0.2 | 20.2±0.2 | 12.0 | 14.3±0.3 |
| PC47PQ26/20Z-12 PC90PQ26/20Z-12 PC95PQ26/20Z-12 | 26.5±0.45 | 19.0±0.45 | 22.5±0.45 | 12.0±0.2 | 20.15±0.25 | 15.5 | 11.5±0.3 |
| PC47PQ26/25Z-12 PC90PQ26/25Z-12 PC95PQ26/25Z-12 | 26.5±0.45 | 19.0±0.45 | 22.5±0.45 | 12.0±0.2 | 24.75±0.25 | 15.5 | 16.1±0.3 |
| PC47PQ32/20Z-12 PC90PQ32/20Z-12 PC95PQ32/20Z-12 | 32.0±0.5 | 22.0±0.5 | 27.5±0.5 | 13.45±0.25 | 20.55±0.25 | 19.0 | 11.5±0.3 |

| Part No. | Effective parameter | | | | | Electrical characteristics | | | | | |
|---|---|---|---|--|--------------|--|--------------|----------------------------|-------|------|-------|
| | Core factor C ₁ (mm ⁻¹) | Effective cross-sectional area A _e (mm ²) | Effective magnetic path length ℓ _e (mm) | Effective core volume V _e (mm ³) | Weigh (g) | AL-value | | Core loss | | | |
| | | | | | | (nH/N ²) 1kHz 0.5mA 100Ts | | (W)max. 100kHz 200mT | 100°C | 25°C | 80°C |
| PC47PQ20/16Z-12 PC90PQ20/16Z-12 PC95PQ20/16Z-12 | 0.605 | 62 | 37.4 | 2310 | 13 | Without air gap | With air gap | 100°C | 25°C | 80°C | 120°C |
| 3880±25% | | | | | | 100±5% | 0.98 | — | — | — | |
| 3100±25% | | | | | | 250±7% | 1.10 | — | — | — | |
| PC47PQ20/20Z-12 PC90PQ20/20Z-12 PC95PQ20/20Z-12 | 0.738 | 62 | 45.4 | 2790 | 15 | Without air gap | With air gap | 100°C | 25°C | 80°C | 120°C |
| 3150±25% | | | | | | 100±5% | 1.19 | — | — | — | |
| 2700±25% | | | | | | 160±5% | 1.35 | — | — | — | |
| PC47PQ26/20Z-12 PC90PQ26/20Z-12 PC95PQ26/20Z-12 | 0.391 | 119 | 46.3 | 5490 | 31 | Without air gap | With air gap | 100°C | 25°C | 80°C | 120°C |
| 6170±25% | | | | | | 160±5% | 1.83 | — | — | — | |
| 5550±25% | | | | | | 315±5% | 2.45 | — | — | — | |
| PC47PQ26/25Z-12 PC90PQ26/25Z-12 PC95PQ26/25Z-12 | 0.472 | 118 | 55.5 | 6530 | 36 | Without air gap | With air gap | 100°C | 25°C | 80°C | 120°C |
| 5250±25% | | | | | | 160±5% | 2.2 | — | — | — | |
| 4500±25% | | | | | | 315±5% | 2.9 | — | — | — | |
| PC47PQ32/20Z-12 PC90PQ32/20Z-12 PC95PQ32/20Z-12 | 0.326 | 170 | 55.5 | 9420 | 42 | Without air gap | With air gap | 100°C | 25°C | 80°C | 120°C |
| 7310±25% | | | | | | 160±5% | 2.76 | — | — | — | |
| 6400±25% | | | | | | 315±5% | 3.7 | — | — | — | |
| | | | | | | 9120±25% | 630±7% | — | 3.94 | 3.31 | 3.94 |

• All specifications are subject to change without notice.

Mn-Zn PQ Cores



SHAPES AND DIMENSIONS

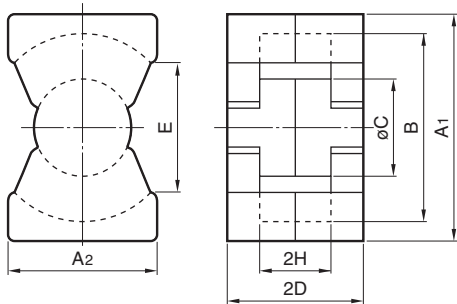

| | | | | | |
|-----------------|------------------------|--|---|-------------------|----------------------------|
| PC47 | PQ32/30 | Z | - | 1 | 2 |
| Material | Size of PQ core | AL-value (Z: without air gap) | | Type | Number of lead slot |
| | | | | 1 Without air gap | |
| | | | | 2 With air gap | |

| Part No. | Dimensions (mm) | | | | | | |
|---|-----------------|----------|----------|------------|------------|--------|----------|
| | A1 | A2 | B | øC | 2D | E min. | 2H |
| PC47PQ32/30Z-12 PC90PQ32/30Z-12 PC95PQ32/30Z-12 | 32.0±0.5 | 22.0±0.5 | 27.5±0.5 | 13.45±0.25 | 30.35±0.25 | 19.0 | 21.3±0.3 |
| PC47PQ35/35Z-12 PC90PQ35/35Z-12 PC95PQ35/35Z-12 | 35.1±0.6 | 26.0±0.5 | 32.0±0.5 | 14.35±0.25 | 34.75±0.25 | 23.5 | 25.0±0.3 |
| PC47PQ40/40Z-12 PC90PQ40/40Z-12 PC95PQ40/40Z-12 | 40.5±0.9 | 28.0±0.6 | 37.0±0.6 | 14.9±0.3 | 39.75±0.25 | 28.0 | 29.5±0.3 |
| PC47PQ50/50Z-12 PC90PQ50/50Z-12 PC95PQ50/50Z-12 | 50.0±0.7 | 32.0±0.5 | 44.0±0.7 | 20.0±0.35 | 49.95±0.25 | 31.5 | 36.1±0.3 |

| Part No. | Effective parameter | | | | | Electrical characteristics | | | | | | |
|---|--------------------------------------|--|---|---|--------------|--|--------|----------------------------|-------|-------|------|-------|
| | Core factor $C_1(\text{mm}^{-1})$ | Effective cross-sectional area $A_e(\text{mm}^2)$ | Effective magnetic path length $\ell_e(\text{mm})$ | Effective core volume $V_e(\text{mm}^3)$ | Weigh (g) | AL-value | | Core loss | | | | |
| | | | | | | (nH/N ²) 1kHz 0.5mA 100Ts | | (W)max. 100kHz 200mT | 100°C | 25°C | 80°C | 120°C |
| PC47PQ32/30Z-12 PC90PQ32/30Z-12 PC95PQ32/30Z-12 | 0.464 | 161 | 74.6 | 12000 | 55 | 5140±25% | 160±5% | 3.71 | — | — | — | |
| 4900±25% | | | | | | 315±5% | 4.90 | — | — | — | | |
| 7000±25% | | | | | | 630±7% | — | 5.30 | 4.45 | 5.30 | | |
| PC47PQ35/35Z-12 PC90PQ35/35Z-12 PC95PQ35/35Z-12 | 0.448 | 196 | 87.9 | 17300 | 73 | 4860±25% | 160±5% | 4.98 | — | — | — | |
| 4700±25% | | | | | | 315±5% | 6.6 | — | — | — | | |
| 7320±25% | | | | | | 630±7% | — | 7.12 | 5.98 | 7.12 | | |
| PC47PQ40/40Z-12 PC90PQ40/40Z-12 PC95PQ40/40Z-12 | 0.508 | 201 | 102 | 20500 | 95 | 4300±25% | 160±5% | 6.21 | — | — | — | |
| 4300±25% | | | | | | 315±5% | 8.2 | — | — | — | | |
| 6400±25% | | | | | | 630±7% | — | 8.87 | 7.45 | 8.87 | | |
| PC47PQ50/50Z-12 PC90PQ50/50Z-12 PC95PQ50/50Z-12 | 0.346 | 328 | 113 | 37200 | 195 | 6720±25% | 250±5% | 15.26 | — | — | — | |
| 6250±25% | | | | | | 400±5% | 8.4* | — | — | — | | |
| 9700±25% | | | | | | 630±5% | — | 9.00* | 7.50* | 9.00* | | |

* 100kHz, 150mT

• All specifications are subject to change without notice.

Mn-Zn PQ series Part No.: PC47PQ20/16Z-12

SHAPES AND DIMENSIONS

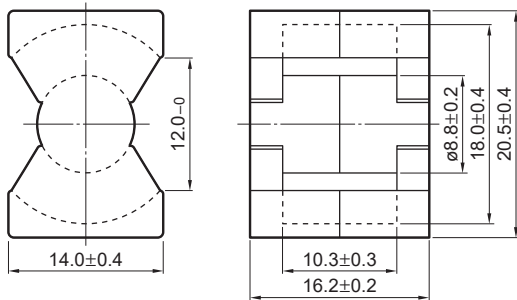

Dimensions in mm

| Effective parameter | | | | | | | | Electrical characteristics | |
|------------------------|---|---|--|--|---|--|----------------|---------------------------------|--------------------------------------|
| Core factor | Effective magnetic path length l_e (mm) | Effective cross-sectional area A_e (mm ²) | Effective core volume V_e (mm ³) | Cross-sectional center pole area A_{cp} (mm ²) | Minimum cross-sectional center pole area $A_{cp \text{ min.}}$ (mm ²) | Cross-sectional winding area of core A_{cw} (mm ²) | Weight (g/set) | AL-value * (nH/N ²) | Core loss (W)max. 100kHz 200mT 100°C |
| C1 (mm ⁻¹) | | | | | | | | (nH/N ²) 1kHz 0.5mA | |
| 0.605 | 37.4 | 62 | 2310 | 60.8 | 58.1 | 47.4 | 13 | 3880±25% | 0.98 |

* Coil : $\phi 0.35$ 2UEW 100Ts

○ Calculated output power (forward converter mode): 77W (100kHz)

NI limit vs. AL-value (Typ.)

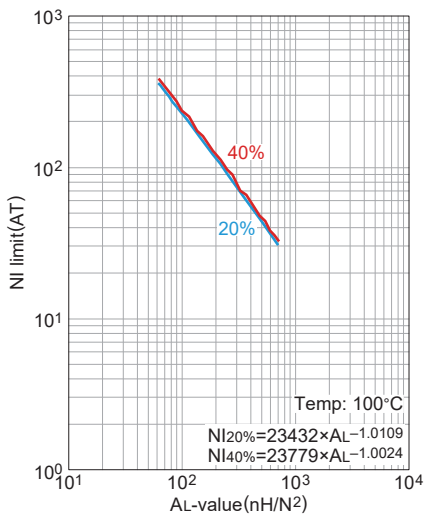

The 20% and 40% graph shows when a 20% and 40% drop from the initial AL-value has been made due to the DC superimposition.

AL-value vs. Air gap length (Typ.)

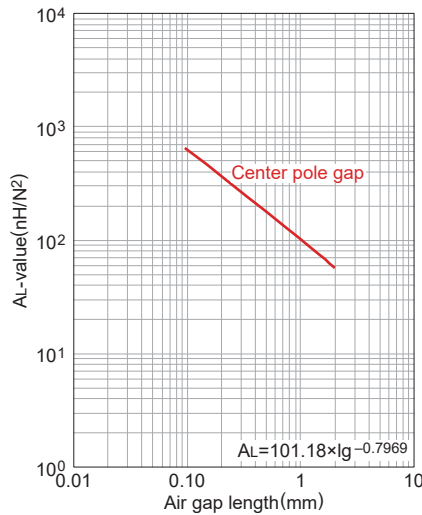

Measuring conditions

- Coil : $\phi 0.35$ 2UEW 100Ts
- Frequency : 1kHz
- Current level : 0.5mA
- Ambient temperature : 25°C

Temperature rise vs. Total loss (Typ.)

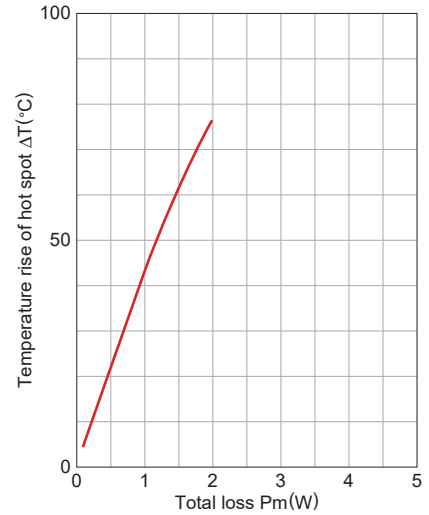

Measuring conditions

- Room space: approx. 400x300x 300cm
- Ambient temperature : 25°C
- Humidity : 45%(%)RH.

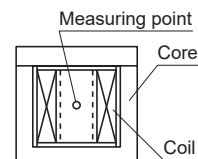

• All specifications are subject to change without notice.

Mn-Zn PQ series Part No.: PC90PQ20/16Z-12

SHAPES AND DIMENSIONS

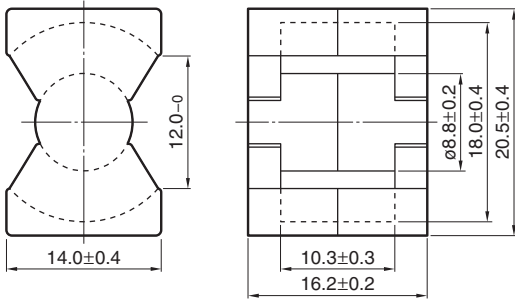

Dimensions in mm

| Effective parameter | | | | | | | | Electrical characteristics | |
|---------------------|---|---|--|--|---|--|----------------|---------------------------------|------------------------------------|
| Core factor | Effective magnetic path length l_e (mm) | Effective cross-sectional area A_e (mm ²) | Effective core volume V_e (mm ³) | Cross-sectional center pole area A_{cp} (mm ²) | Minimum cross-sectional center pole area $A_{cp \text{ min.}}$ (mm ²) | Cross-sectional winding area of core A_{cw} (mm ²) | Weight (g/set) | AL-value * (nH/N ²) | Core loss (W)max. 1kHz 200mT 100°C |
| 0.605 | 37.4 | 62 | 2310 | 60.8 | 58.1 | 47.4 | 13 | 3100±25% | 1.10 |

* Coil : $\phi 0.35$ 2UEW 100Ts

○ Calculated output power (forward converter mode): 70W

NI limit vs. AL-value (Typ.)

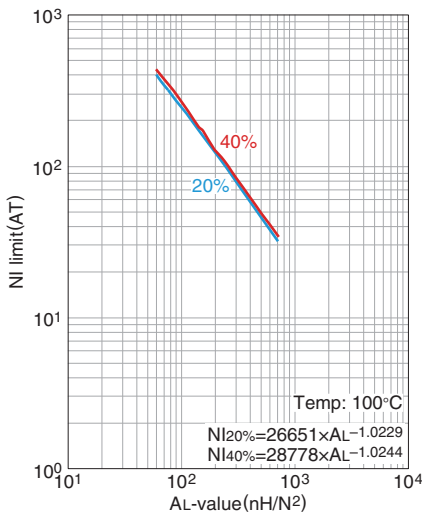

The 20% and 40% graph shows when a 20% and 40% drop from the initial AL-value has been made due to the DC superimposition.

AL-value vs. Air gap length (Typ.)

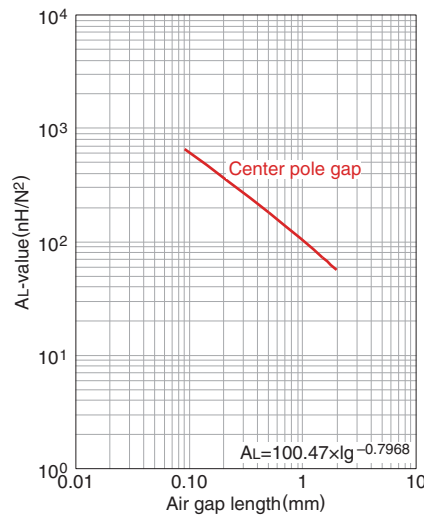

Measuring conditions

- Coil : $\phi 0.35$ 2UEW 100Ts
- Frequency : 1kHz
- Current level : 0.5mA
- Ambient temperature : 25°C

Temperature rise vs. Total loss (Typ.)

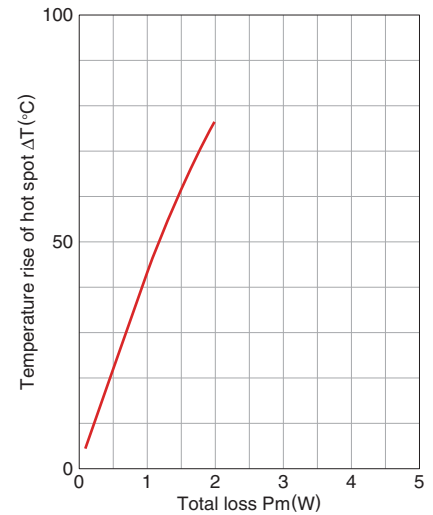

Measuring conditions

- Room space: approx. 400x300x 300cm
- Ambient temperature : 25°C
- Humidity : 45(%)RH.

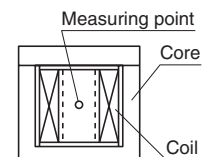

• All specifications are subject to change without notice.

Mn-Zn PQ series Part No.: PC95PQ20/16Z-12

SHAPES AND DIMENSIONS

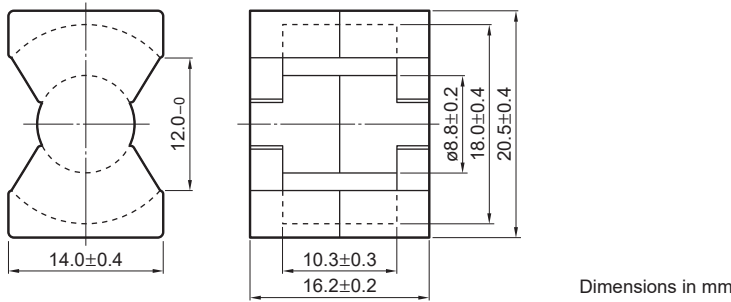

| Effective parameter | | | | | | | | Electrical characteristics | | | |
|---------------------|---|---|--|--|---|--|----------------|--|--------------------------------------|------|-------|
| Core factor | Effective magnetic path length l_e (mm) | Effective cross-sectional area A_e (mm ²) | Effective core volume V_e (mm ³) | Cross-sectional center pole area A_{cp} (mm ²) | Minimum cross-sectional center pole area $A_{cp \text{ min.}}$ (mm ²) | Cross-sectional winding area of core A_{cw} (mm ²) | Weight (g/set) | AL-value * (nH/N ²) 1kHz 0.5mA | Core loss (W)max. 100kHz 200mT | | |
| C ₁ | (mm ⁻¹) | (mm) | (mm ³) | (mm ²) | (mm ²) | (mm ²) | (g/set) | (nH/N ²) 1kHz 0.5mA | 25°C | 80°C | 120°C |
| 0.605 | 37.4 | 62 | 2310 | 60.8 | 58.1 | 47.4 | 13 | 4480±25% | 1.14 | 0.96 | 1.14 |

* Coil : ø0.35 2UEW 100Ts
 ○ Calculated output power (forward converter mode): 74W

NI limit vs. AL-value (Typ.)

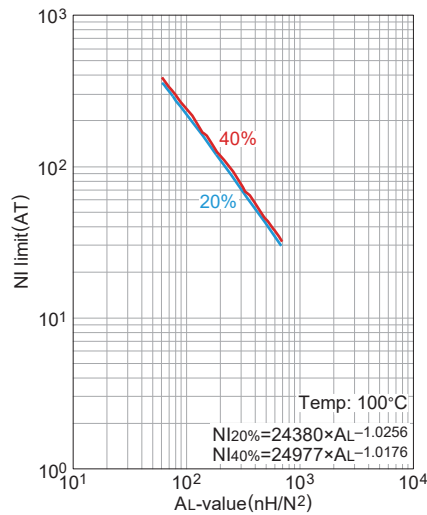

The 20% and 40% graph shows when a 20% and 40% drop from the initial AL-value has been made due to the DC superimposition.

AL-value vs. Air gap length (Typ.)

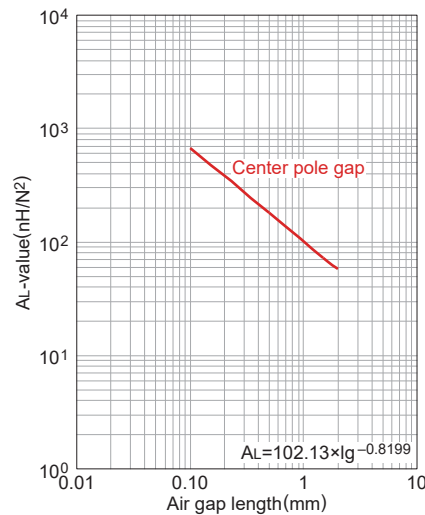

Measuring conditions
 • Coil : ø0.35 2UEW 100Ts
 • Frequency : 1kHz
 • Current level : 0.5mA
 • Ambient temperature : 25°C

Temperature rise vs. Total loss (Typ.)

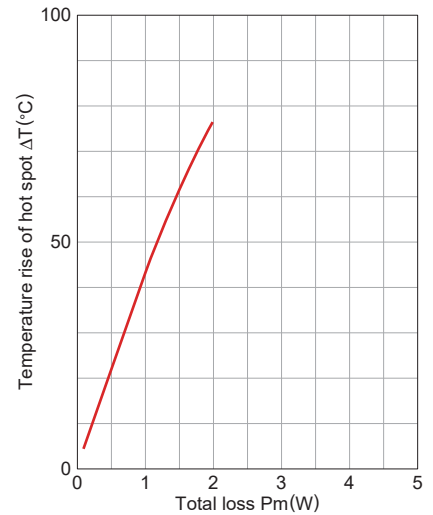

Measuring conditions
 • Room space: approx. 400x300x 300cm
 • Ambient temperature : 25°C
 • Humidity : 45(%)RH.

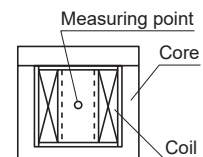

• All specifications are subject to change without notice.

Mn-Zn PQ series Part No.: PC47PQ20/20Z-12

SHAPES AND DIMENSIONS

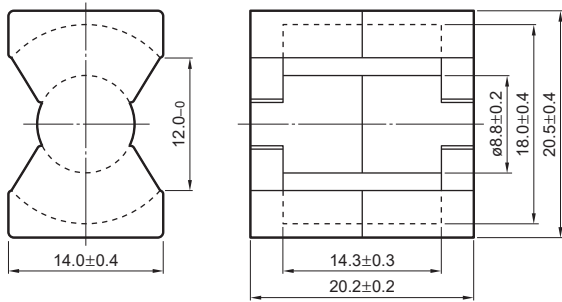

Dimensions in mm

| Effective parameter | | | | | | | | Electrical characteristics | |
|------------------------|---|---|--|--|---|--|----------------|---------------------------------|--------------------------------------|
| Core factor | Effective magnetic path length l_e (mm) | Effective cross-sectional area A_e (mm ²) | Effective core volume V_e (mm ³) | Cross-sectional center pole area A_{cp} (mm ²) | Minimum cross-sectional center pole area $A_{cp \text{ min.}}$ (mm ²) | Cross-sectional winding area of core A_{cw} (mm ²) | Weight (g/set) | AL-value * (nH/N ²) | Core loss (W)max. 100kHz 200mT 100°C |
| C1 (mm ⁻¹) | | | | | | | | (nH/N ²) 1kHz 0.5mA | |
| 0.738 | 45.4 | 62 | 2790 | 60.8 | 58.1 | 65.8 | 15 | 3150±25% | 1.19 |

* Coil : ø0.35 2UEW 100Ts

○ Calculated output power (forward converter mode): 99W (100kHz)

NI limit vs. AL-value (Typ.)

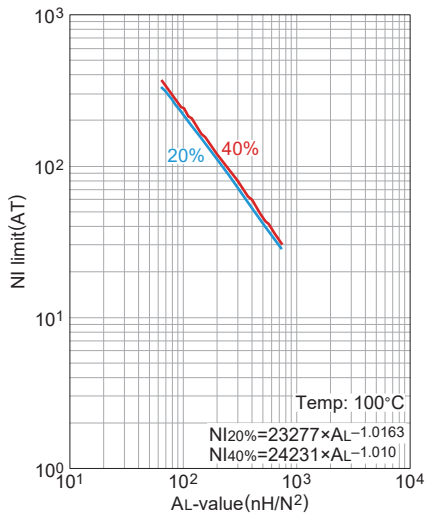

The 20% and 40% graph shows when a 20% and 40% drop from the initial AL-value has been made due to the DC superimposition.

AL-value vs. Air gap length (Typ.)

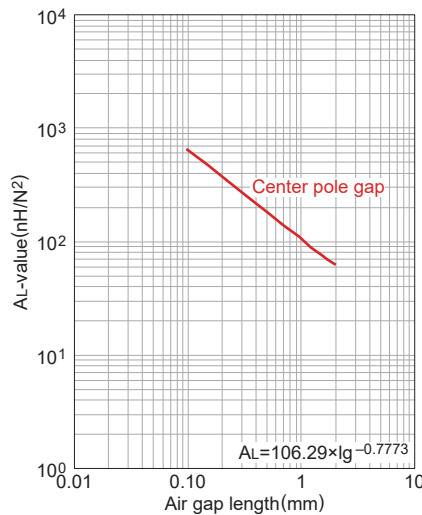

Measuring conditions

- Coil : ø0.35 2UEW 100Ts
- Frequency : 1kHz
- Current level : 0.5mA
- Ambient temperature : 25°C

Temperature rise vs. Total loss (Typ.)

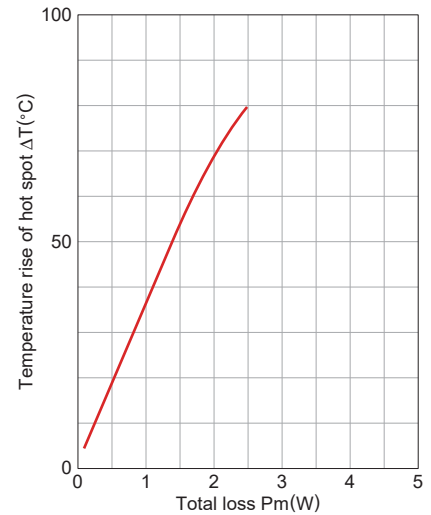

Measuring conditions

- Room space: approx. 400x300x 300cm
- Ambient temperature : 25°C
- Humidity : 45%(%)RH.

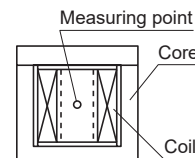

• All specifications are subject to change without notice.

Mn-Zn PQ series Part No.: PC90PQ20/20Z-12

SHAPES AND DIMENSIONS

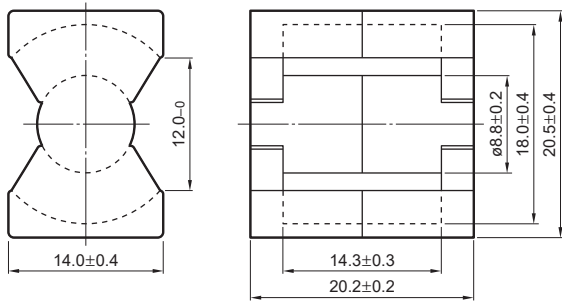

Dimensions in mm

| Effective parameter | | | | | | | | Electrical characteristics | |
|------------------------------|--------------------------------------|--------------------------------------|-----------------------------|---|--|---|---------|---------------------------------------|-------------------------------------|
| Core factor | Effective magnetic path length l_e | Effective cross-sectional area A_e | Effective core volume V_e | Cross-sectional center pole area A_{cp} | Minimum cross-sectional center pole area $A_{cp \text{ min.}}$ | Cross-sectional winding area of core A_{cw} | Weight | AL-value * | Core loss |
| C_1 (mm ⁻¹) | (mm) | (mm ²) | (mm ³) | (mm ²) | (mm ²) | (mm ²) | (g/set) | (nH/N ²) 1kHz 0.5mA | (W)max. 100kHz 200mT 100°C |
| 0.738 | 45.4 | 62 | 2790 | 60.8 | 58.1 | 65.8 | 15 | 2700±25% | 1.35 |

* Coil : ø0.35 2UEW 100Ts

○ Calculated output power (forward converter mode): 92W

NI limit vs. AL-value (Typ.)

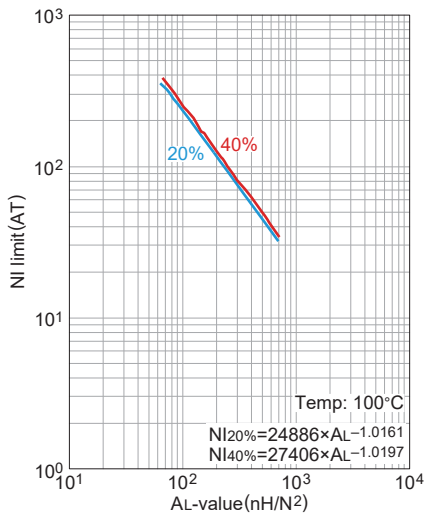

The 20% and 40% graph shows when a 20% and 40% drop from the initial AL-value has been made due to the DC superimposition.

AL-value vs. Air gap length (Typ.)

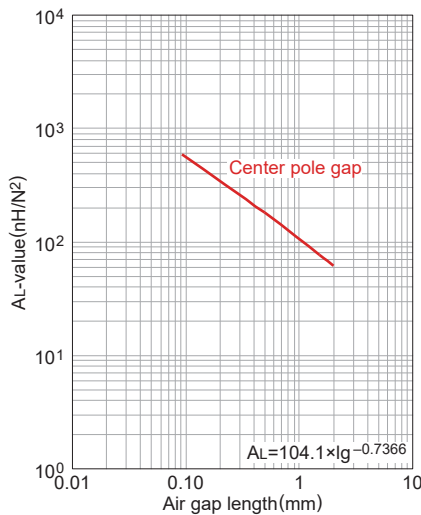

Measuring conditions

- Coil : ø0.35 2UEW 100Ts
- Frequency : 1kHz
- Current level : 0.5mA
- Ambient temperature : 25°C

Temperature rise vs. Total loss (Typ.)

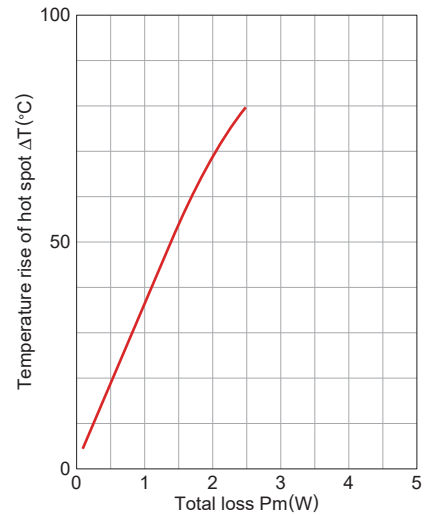

Measuring conditions

- Room space: approx. 400x300x 300cm
- Ambient temperature : 25°C
- Humidity : 45%(%)RH.

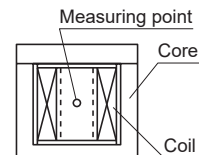

• All specifications are subject to change without notice.

Mn-Zn PQ series Part No.: PC95PQ20/20Z-12

SHAPES AND DIMENSIONS

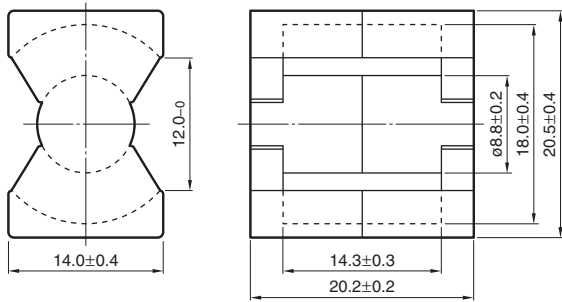

Dimensions in mm

| Effective parameter | | | | | | | | Electrical characteristics | | | |
|---------------------|---|---|--|--|---|--|----------------|---------------------------------|-------------------|------|-------|
| Core factor | Effective magnetic path length l_e (mm) | Effective cross-sectional area A_e (mm ²) | Effective core volume V_e (mm ³) | Cross-sectional center pole area A_{cp} (mm ²) | Minimum cross-sectional center pole area $A_{cp \text{ min.}}$ (mm ²) | Cross-sectional winding area of core A_{cw} (mm ²) | Weight (g/set) | AL-value * (nH/N ²) | Core loss (W)max. | | |
| C_1 | | | | | | | | 1kHz 0.5mA | 25°C | 80°C | 120°C |
| 0.738 | 45.4 | 62 | 2790 | 60.8 | 58.1 | 65.8 | 15 | 4000±25% | 1.38 | 1.16 | 1.38 |

* Coil : $\phi 0.35$ 2UEW 100Ts

○ Calculated output power (forward converter mode): 96W

NI limit vs. AL-value (Typ.)

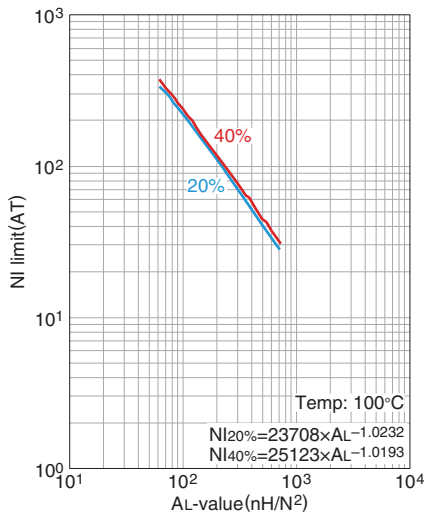

The 20% and 40% graph shows when a 20% and 40% drop from the initial AL-value has been made due to the DC superimposition.

AL-value vs. Air gap length (Typ.)

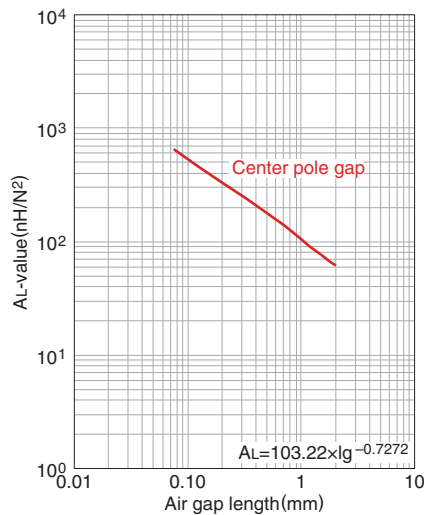

Measuring conditions

- Coil : $\phi 0.35$ 2UEW 100Ts
- Frequency : 1kHz
- Current level : 0.5mA
- Ambient temperature : 25°C

Temperature rise vs. Total loss (Typ.)

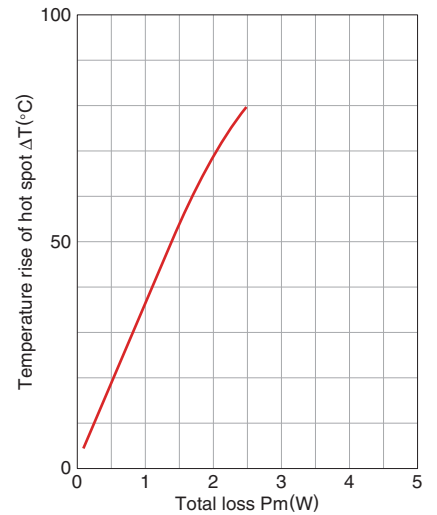

Measuring conditions

- Room space: approx. 400x300x 300cm
- Ambient temperature : 25°C
- Humidity: 45(%RH).

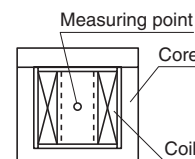

• All specifications are subject to change without notice.

Mn-Zn PQ series Part No.: PC47PQ26/20Z-12

SHAPES AND DIMENSIONS

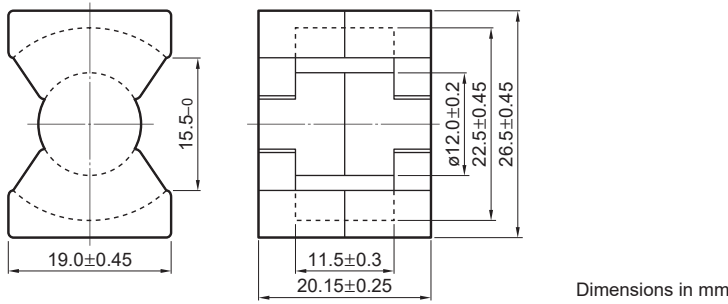

| Effective parameter | | | | | | | | Electrical characteristics | |
|------------------------|---|---|--|--|---|--|----------------|---------------------------------|------------------------------------|
| Core factor | Effective magnetic path length l_e (mm) | Effective cross-sectional area A_e (mm ²) | Effective core volume V_e (mm ³) | Cross-sectional center pole area A_{cp} (mm ²) | Minimum cross-sectional center pole area $A_{cp \text{ min.}}$ (mm ²) | Cross-sectional winding area of core A_{cw} (mm ²) | Weight (g/set) | AL-value * (nH/N ²) | Core loss (W)max. 1kHz 0.5mA 100°C |
| C1 (mm ⁻¹) | | | | | | | | | |
| 0.391 | 46.3 | 119 | 5490 | 113 | 109 | 60.4 | 31 | 6170±25% | 1.83 |

* Coil : $\phi 0.35$ 2UEW 100Ts
 ○ Calculated output power (forward converter mode): 170W (100kHz)

NI limit vs. AL-value (Typ.)

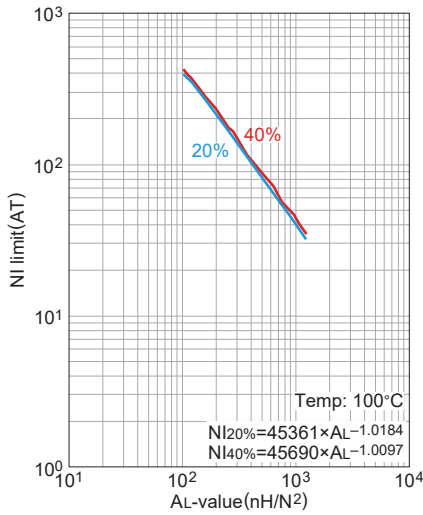

The 20% and 40% graph shows when a 20% and 40% drop from the initial AL-value has been made due to the DC superimposition.

AL-value vs. Air gap length (Typ.)

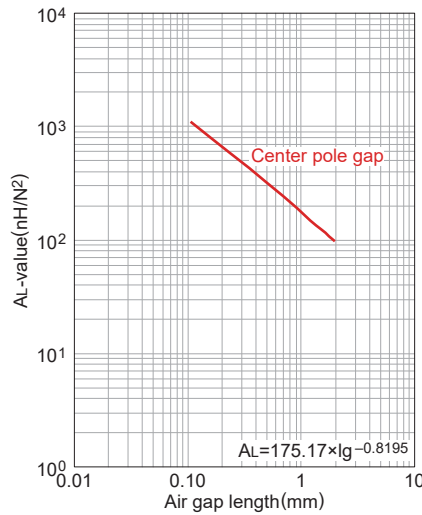

Measuring conditions
 • Coil : $\phi 0.35$ 2UEW 100Ts
 • Frequency : 1kHz
 • Current level : 0.5mA
 • Ambient temperature : 25°C

Temperature rise vs. Total loss (Typ.)

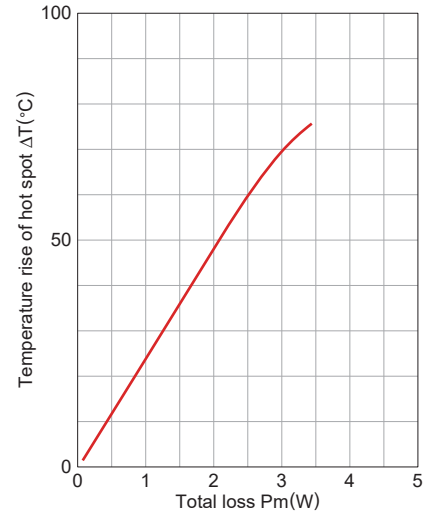

Measuring conditions
 • Room space: approx. 400x300x 300cm
 • Ambient temperature : 25°C
 • Humidity: 45(%)RH.

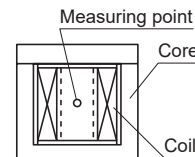

• All specifications are subject to change without notice.

Mn-Zn PQ series Part No.: PC90PQ26/20Z-12

SHAPES AND DIMENSIONS

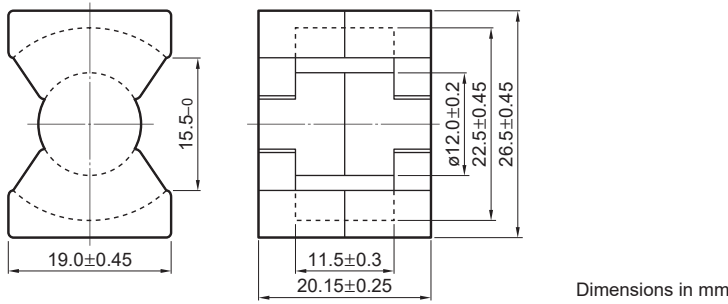

| Effective parameter | | | | | | | | Electrical characteristics | |
|------------------------|---|---|--|--|---|--|----------------|---------------------------------|------------------------------------|
| Core factor | Effective magnetic path length l_e (mm) | Effective cross-sectional area A_e (mm ²) | Effective core volume V_e (mm ³) | Cross-sectional center pole area A_{cp} (mm ²) | Minimum cross-sectional center pole area $A_{cp \text{ min.}}$ (mm ²) | Cross-sectional winding area of core A_{cw} (mm ²) | Weight (g/set) | AL-value * (nH/N ²) | Core loss (W)max. 1kHz 200mT 100°C |
| C1 (mm ⁻¹) | 46.3 | 119 | 5490 | 113 | 109 | 60.4 | 31 | 5500±25% | 2.45 |

* Coil : $\phi 0.35$ 2UEW 100Ts
 ○ Calculated output power (forward converter mode): 145W

NI limit vs. AL-value (Typ.)

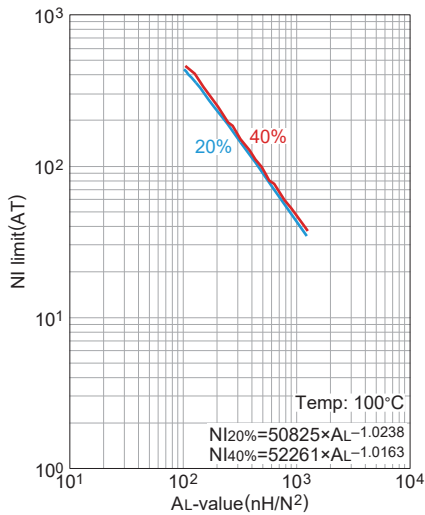

The 20% and 40% graph shows when a 20% and 40% drop from the initial AL-value has been made due to the DC superimposition.

AL-value vs. Air gap length (Typ.)

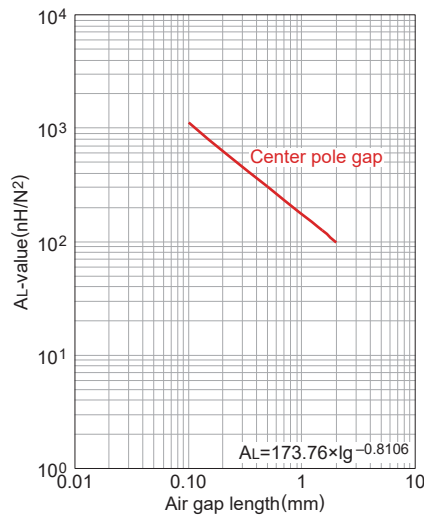

Measuring conditions
 • Coil : $\phi 0.35$ 2UEW 100Ts
 • Frequency : 1kHz
 • Current level : 0.5mA
 • Ambient temperature : 25°C

Temperature rise vs. Total loss (Typ.)

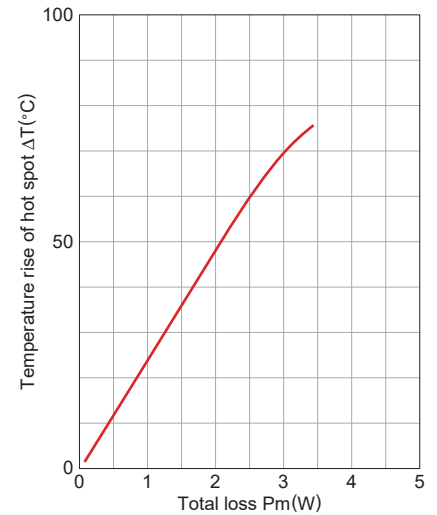

Measuring conditions
 • Room space: approx. 400x300x 300cm
 • Ambient temperature : 25°C
 • Humidity: 45%(%)RH.

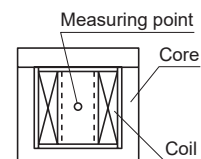

• All specifications are subject to change without notice.

Mn-Zn PQ series Part No.: PC95PQ26/20Z-12

SHAPES AND DIMENSIONS

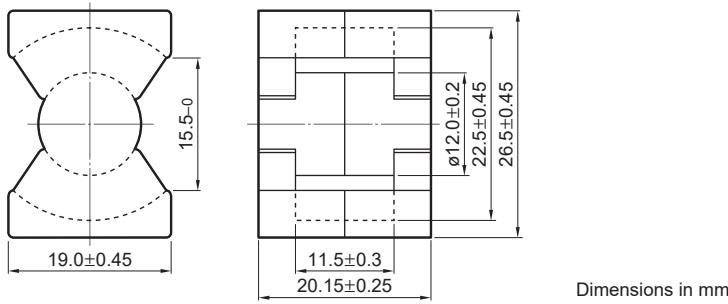

| Effective parameter | | | | | | | | Electrical characteristics | | | |
|------------------------------------|---|---|--|--|---|--|----------------|---------------------------------|-------------------|------|-------|
| Core factor | Effective magnetic path length l_e (mm) | Effective cross-sectional area A_e (mm ²) | Effective core volume V_e (mm ³) | Cross-sectional center pole area A_{cp} (mm ²) | Minimum cross-sectional center pole area $A_{cp \text{ min.}}$ (mm ²) | Cross-sectional winding area of core A_{cw} (mm ²) | Weight (g/set) | AL-value * (nH/N ²) | Core loss (W)max. | | |
| C ₁ (mm ⁻¹) | | | | | | | | 1kHz 0.5mA | 25°C | 80°C | 120°C |
| 0.391 | 46.3 | 119 | 5490 | 113 | 109 | 60.4 | 31 | 7470±25% | 2.62 | 2.20 | 2.62 |

* Coil : ø0.35 2UEW 100Ts
 ○ Calculated output power (forward converter mode): 160W

NI limit vs. AL-value (Typ.)

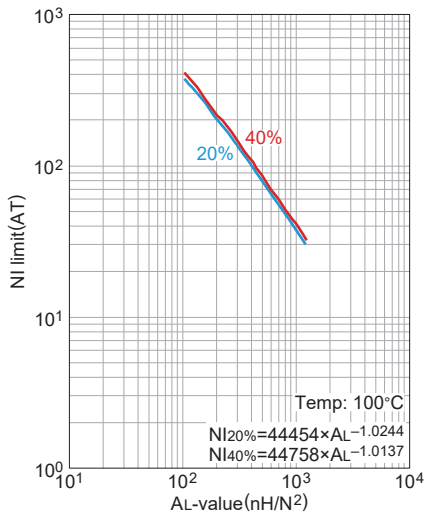

The 20% and 40% graph shows when a 20% and 40% drop from the initial AL-value has been made due to the DC superimposition.

AL-value vs. Air gap length (Typ.)

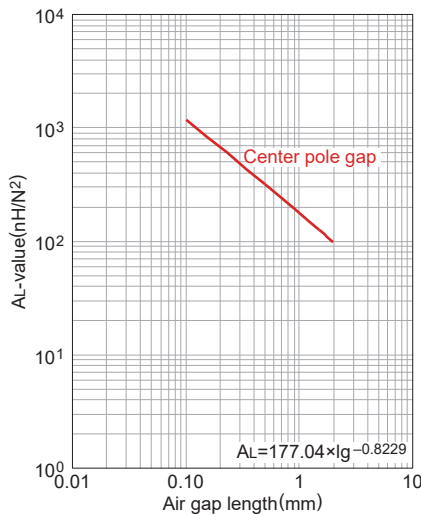

Measuring conditions
 • Coil : ø0.35 2UEW 100Ts
 • Frequency : 1kHz
 • Current level : 0.5mA
 • Ambient temperature : 25°C

Temperature rise vs. Total loss (Typ.)

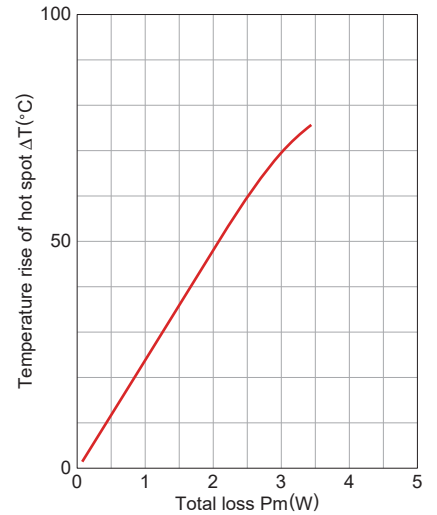

Measuring conditions
 • Room space: approx. 400x300x 300cm
 • Ambient temperature : 25°C
 • Humidity: 45(%RH).

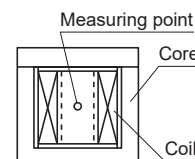

• All specifications are subject to change without notice.

Mn-Zn PQ series Part No.: PC47PQ26/25Z-12

SHAPES AND DIMENSIONS

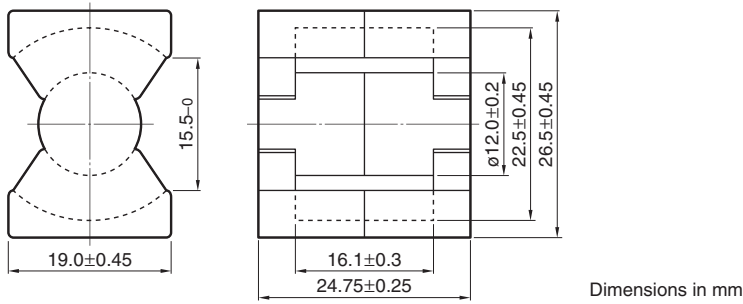

| Effective parameter | | | | | | | | Electrical characteristics | |
|------------------------------------|---|---|--|--|---|--|----------------|---------------------------------|------------------------------------|
| Core factor | Effective magnetic path length l_e (mm) | Effective cross-sectional area A_e (mm ²) | Effective core volume V_e (mm ³) | Cross-sectional center pole area A_{cp} (mm ²) | Minimum cross-sectional center pole area $A_{cp \text{ min.}}$ (mm ²) | Cross-sectional winding area of core A_{cw} (mm ²) | Weight (g/set) | AL-value * (nH/N ²) | Core loss (W)max. 1kHz 0.5mA 100°C |
| C ₁ (mm ⁻¹) | | | | | | | | | |
| 0.472 | 55.5 | 118 | 6530 | 113 | 109 | 84.5 | 36 | 5250±25% | 2.2 |

* Coil : $\phi 0.35$ 2UEW 100Ts

○ Calculated output power (forward converter mode): 221W (100kHz)

NI limit vs. AL-value (Typ.)

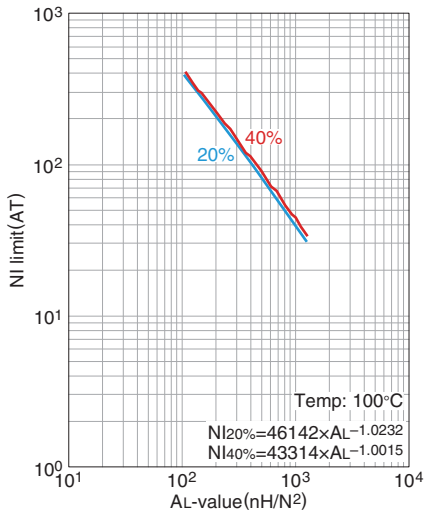

The 20% and 40% graph shows when a 20% and 40% drop from the initial AL-value has been made due to the DC superimposition.

AL-value vs. Air gap length (Typ.)

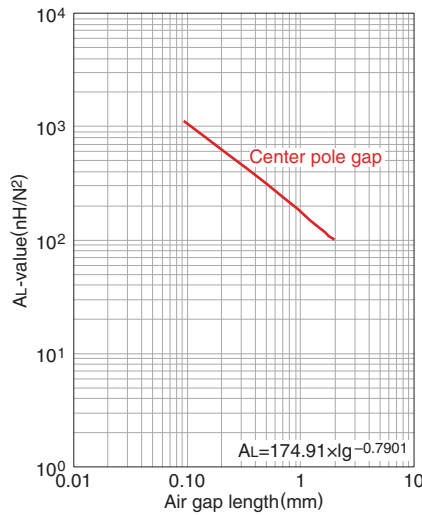

Measuring conditions
 • Coil : $\phi 0.35$ 2UEW 100Ts
 • Frequency : 1kHz
 • Current level : 0.5mA
 • Ambient temperature : 25°C

Temperature rise vs. Total loss (Typ.)

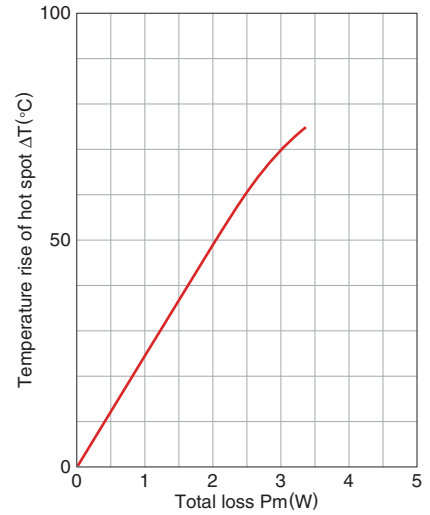

Measuring conditions
 • Room space: approx. 400x300x 300cm
 • Ambient temperature : 25°C
 • Humidity : 45%(%)RH.

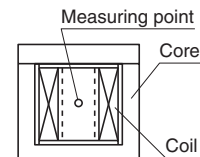

• All specifications are subject to change without notice.

Mn-Zn PQ series Part No.: PC90PQ26/25Z-12

SHAPES AND DIMENSIONS

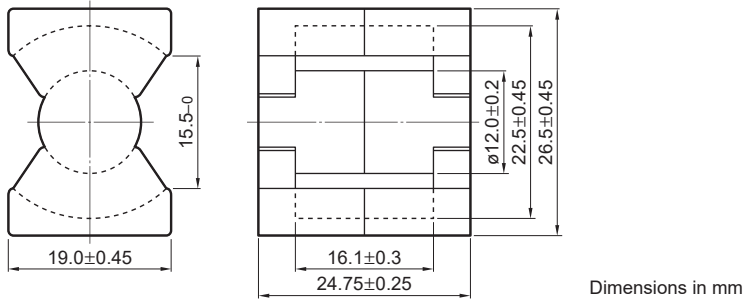

| Effective parameter | | | | | | | | Electrical characteristics | |
|------------------------------|--------------------------------------|--------------------------------------|-----------------------------|---|--|---|---------|---------------------------------------|-------------------------------------|
| Core factor | Effective magnetic path length l_e | Effective cross-sectional area A_e | Effective core volume V_e | Cross-sectional center pole area A_{cp} | Minimum cross-sectional center pole area $A_{cp \text{ min.}}$ | Cross-sectional winding area of core A_{cw} | Weight | AL-value * | Core loss |
| C_1 (mm ⁻¹) | (mm) | (mm ²) | (mm ³) | (mm ²) | (mm ²) | (mm ²) | (g/set) | (nH/N ²) 1kHz 0.5mA | (W)max. 100kHz 200mT 100°C |
| 0.472 | 55.5 | 118 | 6530 | 113 | 109 | 84.5 | 36 | 4500±25% | 2.9 |

* Coil : $\phi 0.35$ 2UEW 100Ts
 ○ Calculated output power (forward converter mode): 195W

NI limit vs. AL-value (Typ.)

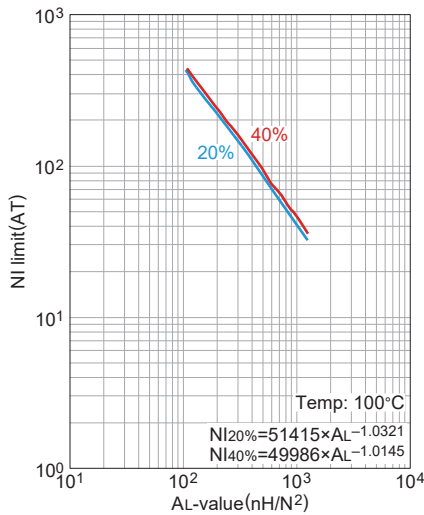

The 20% and 40% graph shows when a 20% and 40% drop from the initial AL-value has been made due to the DC superimposition.

AL-value vs. Air gap length (Typ.)

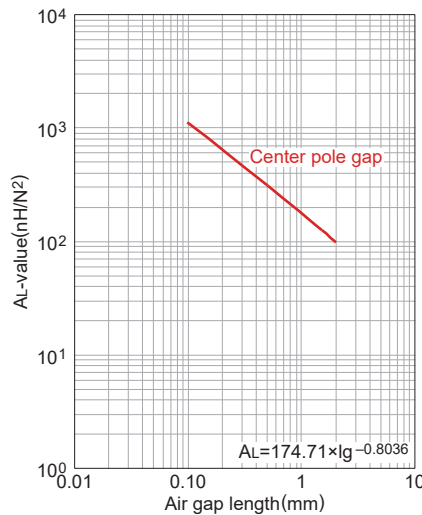

Measuring conditions
 • Coil : $\phi 0.35$ 2UEW 100Ts
 • Frequency : 1kHz
 • Current level : 0.5mA
 • Ambient temperature : 25°C

Temperature rise vs. Total loss (Typ.)

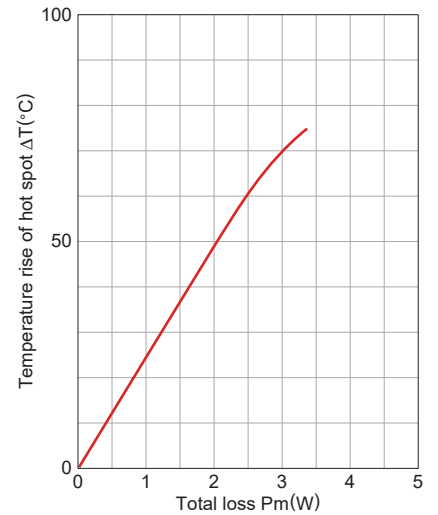

Measuring conditions
 • Room space: approx. 400x300x 300cm
 • Ambient temperature : 25°C
 • Humidity : 45(%)RH.

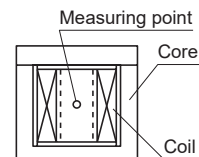

• All specifications are subject to change without notice.

Mn-Zn PQ series Part No.: PC95PQ26/25Z-12

SHAPES AND DIMENSIONS

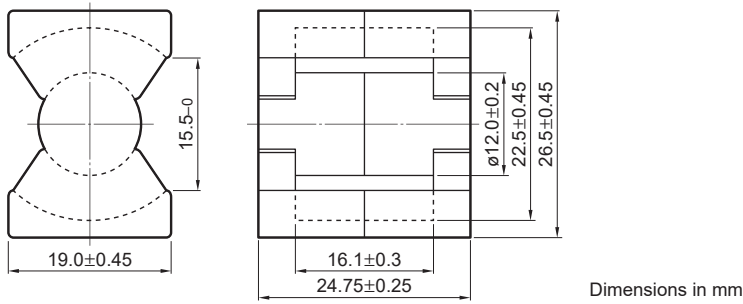

| Effective parameter | | | | | | | | Electrical characteristics | | | | |
|---------------------|---|---|--|--|---|--|----------------|---------------------------------------|-------------------|------|------|-------|
| Core factor | Effective magnetic path length l_e (mm) | Effective cross-sectional area A_e (mm ²) | Effective core volume V_e (mm ³) | Cross-sectional center pole area A_{cp} (mm ²) | Minimum cross-sectional center pole area $A_{cp \text{ min.}}$ (mm ²) | Cross-sectional winding area of core A_{cw} (mm ²) | Weight (g/set) | AL-value * (nH/N ²) | Core loss (W)max. | | | |
| C ₁ | (mm ⁻¹) | (mm) | (mm ³) | (mm ²) | (mm ²) | (mm ²) | (g/set) | (nH/N ²) 1kHz 0.5mA | 100kHz 200mT | 25°C | 80°C | 120°C |
| 0.472 | 55.5 | 118 | 6530 | 113 | 109 | 84.5 | 36 | 6520±25% | 3.14 | 2.63 | 3.14 | |

* Coil : $\phi 0.35$ 2UEW 100Ts
 ○ Calculated output power (forward converter mode): 206W

NI limit vs. AL-value (Typ.)

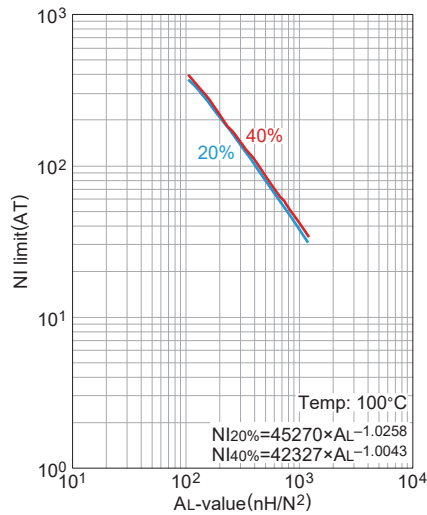

The 20% and 40% graph shows when a 20% and 40% drop from the initial AL-value has been made due to the DC superimposition.

AL-value vs. Air gap length (Typ.)

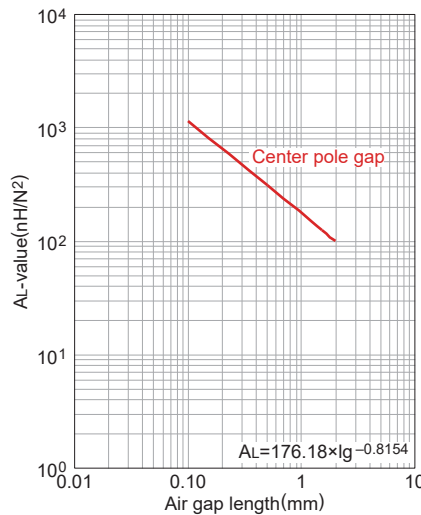

Measuring conditions
 • Coil : $\phi 0.35$ 2UEW 100Ts
 • Frequency : 1kHz
 • Current level : 0.5mA
 • Ambient temperature : 25°C

Temperature rise vs. Total loss (Typ.)

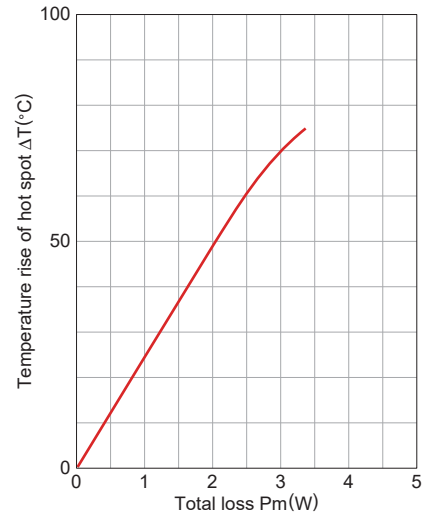

Measuring conditions
 • Room space: approx. 400x300x 300cm
 • Ambient temperature : 25°C
 • Humidity: 45%RH.

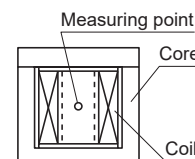

• All specifications are subject to change without notice.

Mn-Zn PQ series Part No.: PC47PQ32/20Z-12

SHAPES AND DIMENSIONS

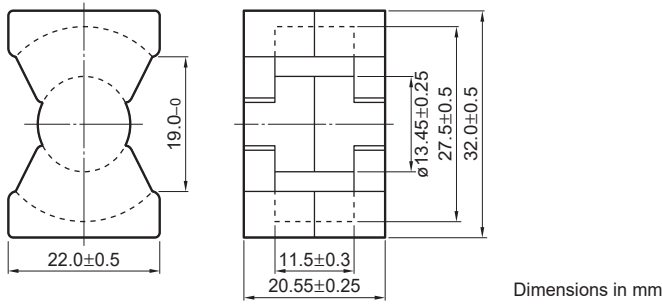

| Effective parameter | | | | | | | | Electrical characteristics | |
|------------------------|---|---|--|--|---|--|----------------|---------------------------------|------------------------------------|
| Core factor | Effective magnetic path length l_e (mm) | Effective cross-sectional area A_e (mm ²) | Effective core volume V_e (mm ³) | Cross-sectional center pole area A_{cp} (mm ²) | Minimum cross-sectional center pole area $A_{cp \text{ min.}}$ (mm ²) | Cross-sectional winding area of core A_{cw} (mm ²) | Weight (g/set) | AL-value * (nH/N ²) | Core loss (W)max. 1kHz 0.5mA 100°C |
| C1 (mm ⁻¹) | | | | | | | | | |
| 0.326 | 55.5 | 170 | 9420 | 142 | 137 | 80.8 | 42 | 7310±25% | 2.76 |

* Coil : ø0.35 2UEW 100Ts
 ○ Calculated output power (forward converter mode): 245W (100kHz)

NI limit vs. AL-value (Typ.)

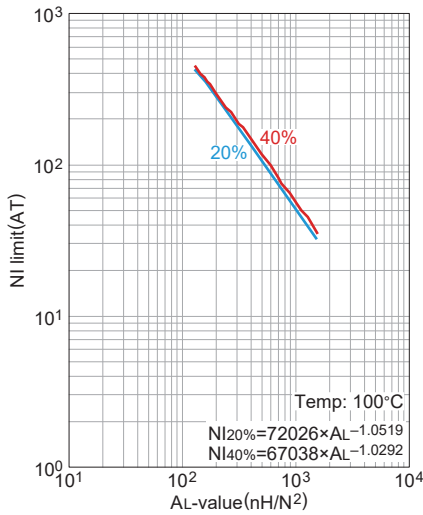

The 20% and 40% graph shows when a 20% and 40% drop from the initial AL-value has been made due to the DC superimposition.

AL-value vs. Air gap length (Typ.)

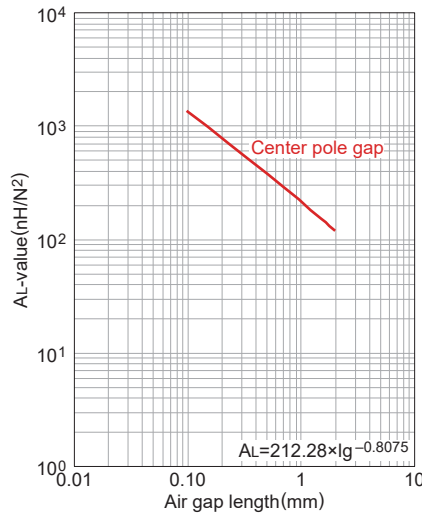

Measuring conditions
 • Coil : ø0.35 2UEW 100Ts
 • Frequency : 1kHz
 • Current level : 0.5mA
 • Ambient temperature : 25°C

Temperature rise vs. Total loss (Typ.)

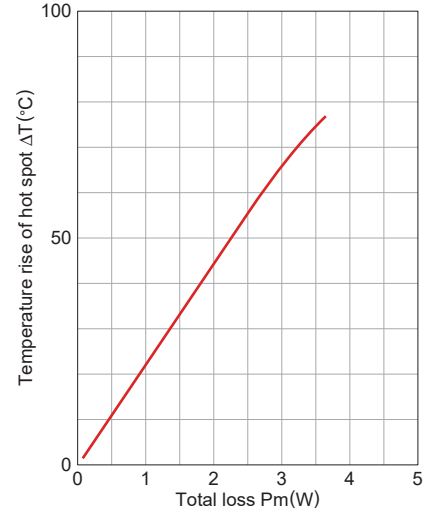

Measuring conditions
 • Room space: approx. 400x300x 300cm
 • Ambient temperature : 25°C
 • Humidity: 45(%)RH.

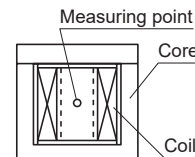

• All specifications are subject to change without notice.

Mn-Zn PQ series Part No.: PC90PQ32/20Z-12

SHAPES AND DIMENSIONS

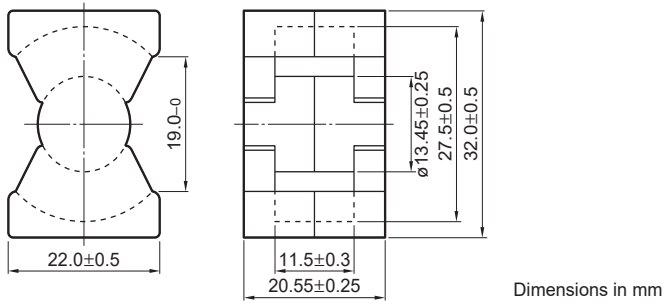

| Effective parameter | | | | | | | | Electrical characteristics | |
|---------------------|---|---|--|--|---|--|----------------|---------------------------------|------------------------------------|
| Core factor | Effective magnetic path length l_e (mm) | Effective cross-sectional area A_e (mm ²) | Effective core volume V_e (mm ³) | Cross-sectional center pole area A_{cp} (mm ²) | Minimum cross-sectional center pole area $A_{cp \text{ min.}}$ (mm ²) | Cross-sectional winding area of core A_{cw} (mm ²) | Weight (g/set) | AL-value * (nH/N ²) | Core loss (W)max. 1kHz 0.5mA 100°C |
| 0.326 | 55.5 | 170 | 9420 | 142 | 137 | 80.8 | 42 | 6400±25% | 3.7 |

* Coil : $\phi 0.35$ 2UEW 100Ts
 ○ Calculated output power (forward converter mode): 224W

NI limit vs. AL-value (Typ.)

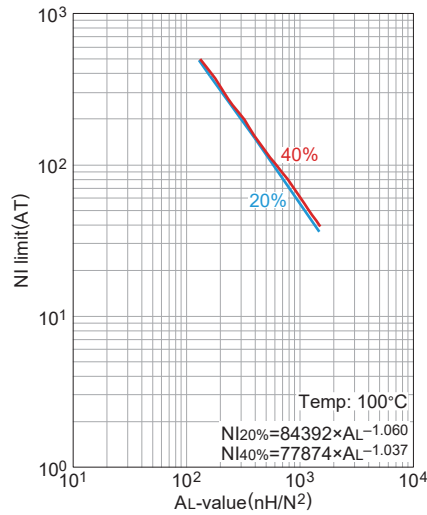

The 20% and 40% graph shows when a 20% and 40% drop from the initial AL-value has been made due to the DC superimposition.

AL-value vs. Air gap length (Typ.)

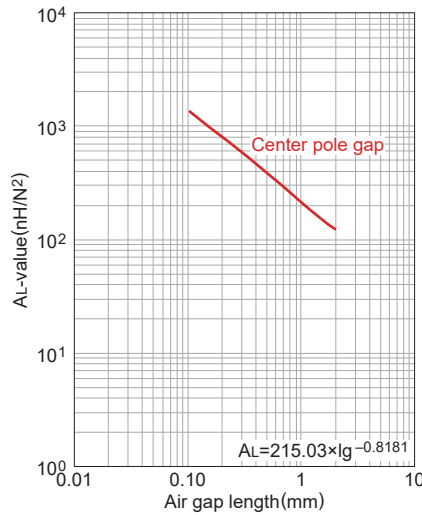

Measuring conditions
 • Coil : $\phi 0.35$ 2UEW 100Ts
 • Frequency : 1kHz
 • Current level : 0.5mA
 • Ambient temperature : 25°C

Temperature rise vs. Total loss (Typ.)

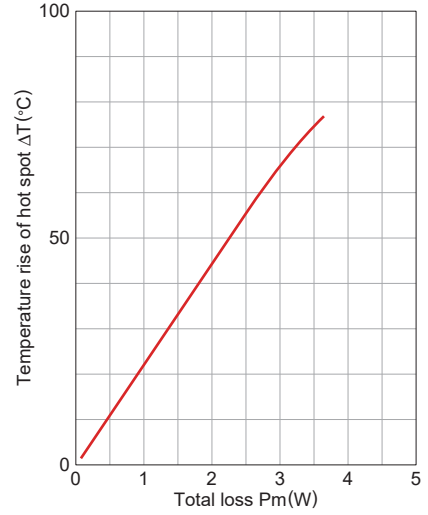

Measuring conditions
 • Room space: approx. 400x300x 300cm
 • Ambient temperature : 25°C
 • Humidity: 45%(%)RH.

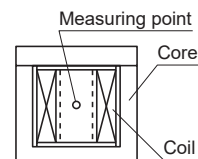

• All specifications are subject to change without notice.

Mn-Zn PQ series Part No.: PC95PQ32/20Z-12

SHAPES AND DIMENSIONS

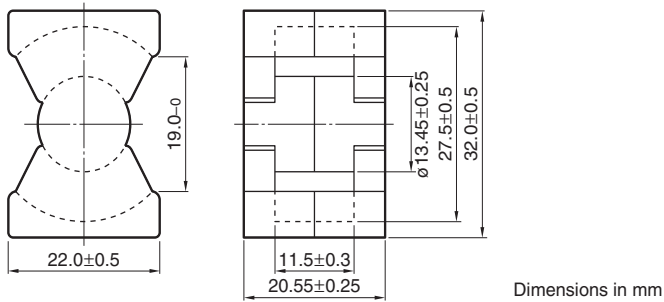

| Effective parameter | | | | | | | | Electrical characteristics | | | |
|------------------------------------|---|---|--|--|---|--|----------------|---------------------------------|-------------------|------|-------|
| Core factor | Effective magnetic path length l_e (mm) | Effective cross-sectional area A_e (mm ²) | Effective core volume V_e (mm ³) | Cross-sectional center pole area A_{cp} (mm ²) | Minimum cross-sectional center pole area $A_{cp \text{ min.}}$ (mm ²) | Cross-sectional winding area of core A_{cw} (mm ²) | Weight (g/set) | AL-value * (nH/N ²) | Core loss (W)max. | | |
| C ₁ (mm ⁻¹) | | | | | | | | 1kHz 0.5mA | 25°C | 80°C | 120°C |
| 0.326 | 55.5 | 170 | 9420 | 142 | 137 | 80.8 | 42 | 9120±25% | 3.94 | 3.31 | 3.94 |

* Coil : $\phi 0.35$ 2UEW 100Ts
 ○ Calculated output power (forward converter mode): 237W

NI limit vs. AL-value (Typ.)

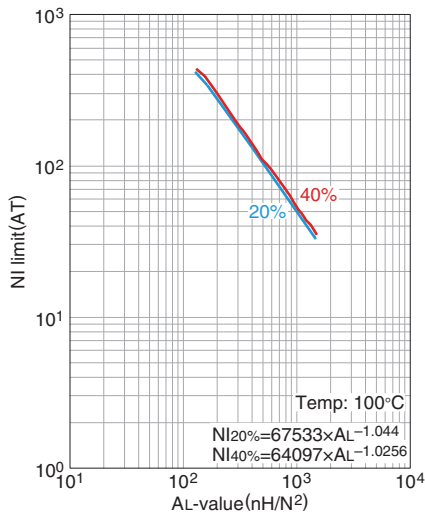

The 20% and 40% graph shows when a 20% and 40% drop from the initial AL-value has been made due to the DC superimposition.

AL-value vs. Air gap length (Typ.)

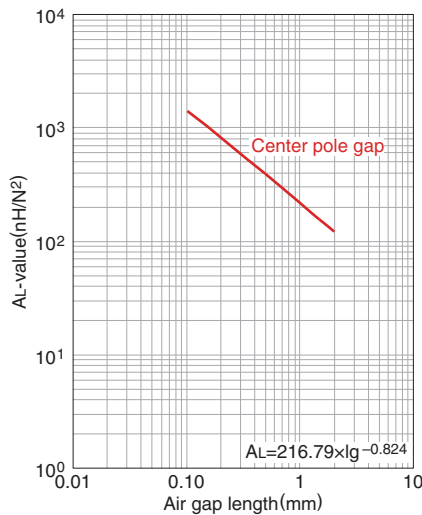

Measuring conditions
 • Coil : $\phi 0.35$ 2UEW 100Ts
 • Frequency : 1kHz
 • Current level : 0.5mA
 • Ambient temperature : 25°C

Temperature rise vs. Total loss (Typ.)

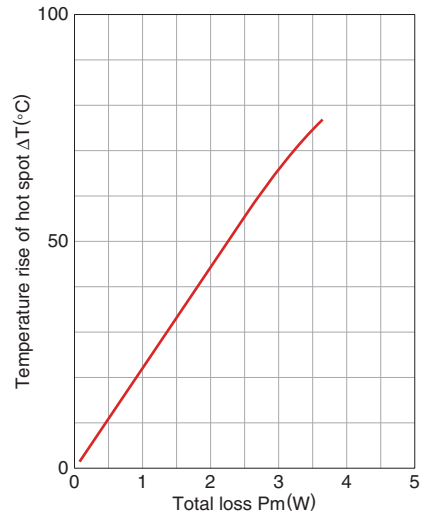

Measuring conditions
 • Room space: approx. 400x300x 300cm
 • Ambient temperature : 25°C
 • Humidity: 45%(%)RH.

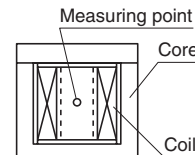

• All specifications are subject to change without notice.

Mn-Zn PQ series Part No.: PC47PQ32/30Z-12

SHAPES AND DIMENSIONS

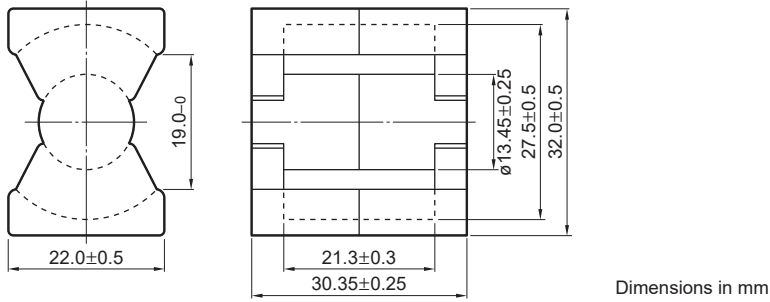

| Effective parameter | | | | | | | | Electrical characteristics | |
|------------------------|---|---|--|--|---|--|----------------|---------------------------------|------------------------------------|
| Core factor | Effective magnetic path length l_e (mm) | Effective cross-sectional area A_e (mm ²) | Effective core volume V_e (mm ³) | Cross-sectional center pole area A_{cp} (mm ²) | Minimum cross-sectional center pole area $A_{cp \text{ min.}}$ (mm ²) | Cross-sectional winding area of core A_{cw} (mm ²) | Weight (g/set) | AL-value * (nH/N ²) | Core loss (W)max. 1kHz 0.5mA 100°C |
| C1 (mm ⁻¹) | | | | | | | | | |
| 0.464 | 74.6 | 161 | 12000 | 142 | 137 | 149.6 | 55 | 5140±25% | 3.71 |

* Coil : $\phi 0.4$ 2UEW 100Ts
 ○ Calculated output power (forward converter mode): 374W (100kHz)

NI limit vs. AL-value (Typ.)

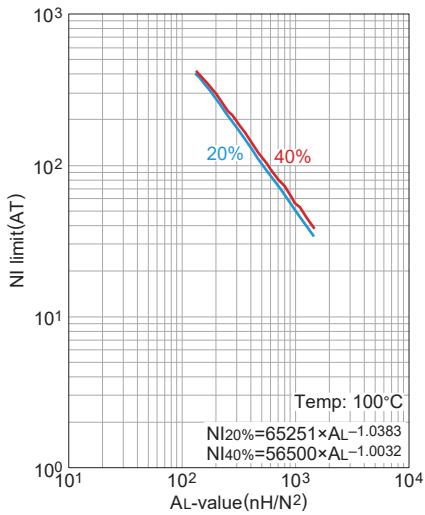

The 20% and 40% graph shows when a 20% and 40% drop from the initial AL-value has been made due to the DC superimposition.

AL-value vs. Air gap length (Typ.)

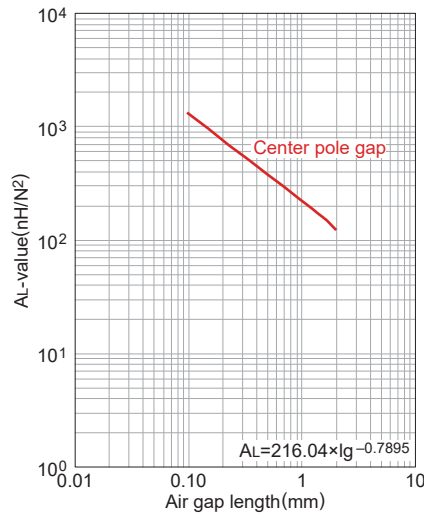

Measuring conditions
 • Coil : $\phi 0.4$ 2UEW 100Ts
 • Frequency : 1kHz
 • Current level : 0.5mA
 • Ambient temperature : 25°C

Temperature rise vs. Total loss (Typ.)

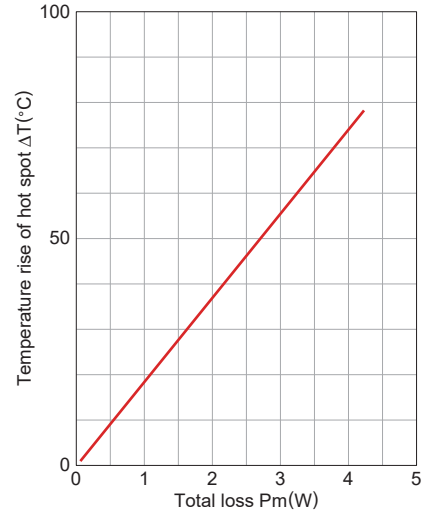

Measuring conditions
 • Room space: approx. 400x300x 300cm
 • Ambient temperature : 25°C
 • Humidity : 45%(%)RH.

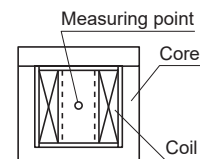

• All specifications are subject to change without notice.

Mn-Zn PQ series **Part No.: PC90PQ32/30Z-12**

■ SHAPES AND DIMENSIONS

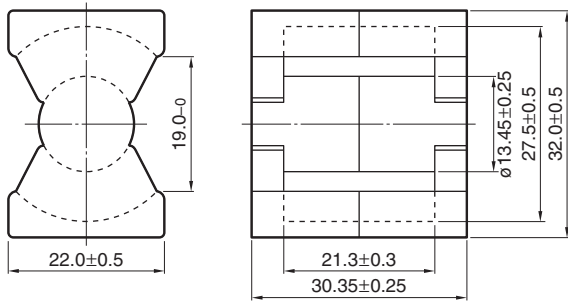

Dimensions in mm

| Effective parameter | | | | | | | | Electrical characteristics | |
|------------------------------------|---|---|--|--|---|--|----------------|---------------------------------|------------------------------------|
| Core factor | Effective magnetic path length l_e (mm) | Effective cross-sectional area A_e (mm ²) | Effective core volume V_e (mm ³) | Cross-sectional center pole area A_{cp} (mm ²) | Minimum cross-sectional center pole area $A_{cp \text{ min.}}$ (mm ²) | Cross-sectional winding area of core A_{cw} (mm ²) | Weight (g/set) | AL-value * (nH/N ²) | Core loss (W)max. 1kHz 0.5mA 100°C |
| C ₁ (mm ⁻¹) | | | | | | | | | |
| 0.464 | 74.6 | 161 | 12000 | 142 | 137 | 149.6 | 55 | 4900±25% | 4.90 |

* Coil : ø0.4 2UEW 100Ts

○ Calculated output power (forward converter mode): 348W

NI limit vs. AL-value (Typ.)

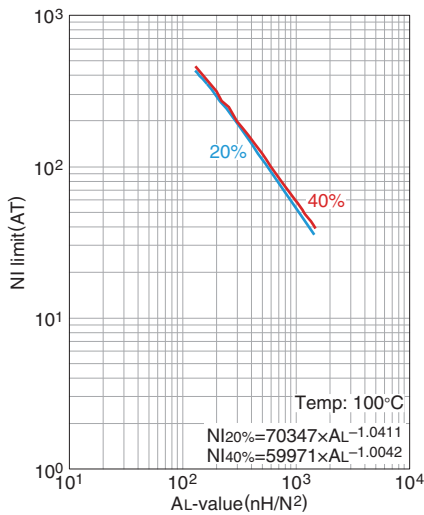

The 20% and 40% graph shows when a 20% and 40% drop from the initial AL-value has been made due to the DC superimposition.

AL-value vs. Air gap length (Typ.)

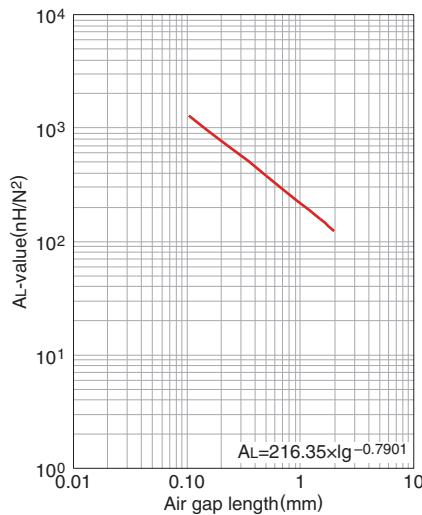

Measuring conditions

- Coil : ø0.4 2UEW 100Ts
- Frequency : 1kHz
- Current level : 0.5mA
- Ambient temperature : 25°C

Temperature rise vs. Total loss (Typ.)

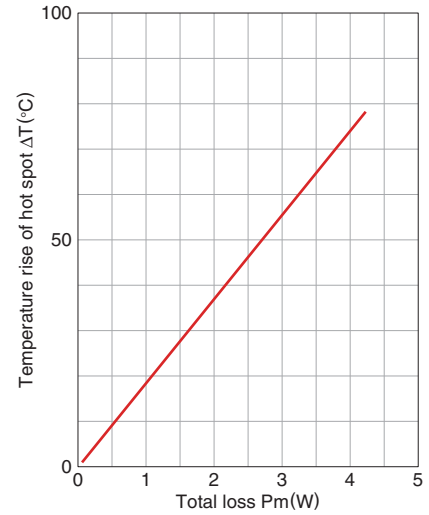

Measuring conditions

- Room space: approx. 400x300x 300cm
- Ambient temperature : 25°C
- Humidity : 45%(%)RH.

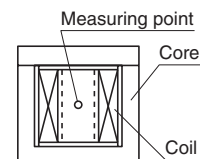

• All specifications are subject to change without notice.

Mn-Zn PQ series Part No.: PC95PQ32/30Z-12

SHAPES AND DIMENSIONS

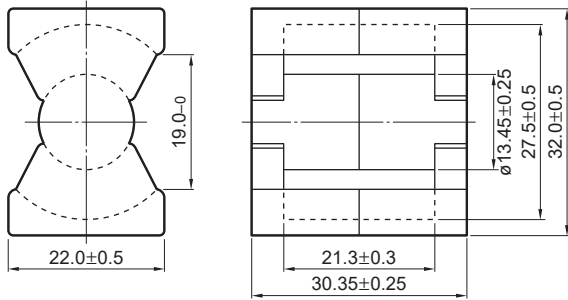

Dimensions in mm

| Effective parameter | | | | | | | | Electrical characteristics | | | |
|---------------------|---|---|--|--|---|--|----------------|---------------------------------------|-------------------|------|-------|
| Core factor | Effective magnetic path length l_e (mm) | Effective cross-sectional area A_e (mm ²) | Effective core volume V_e (mm ³) | Cross-sectional center pole area A_{cp} (mm ²) | Minimum cross-sectional center pole area $A_{cp \text{ min.}}$ (mm ²) | Cross-sectional winding area of core A_{cw} (mm ²) | Weight (g/set) | AL-value * (nH/N ²) | Core loss (W)max. | | |
| C ₁ | (mm ⁻¹) | (mm) | (mm ³) | (mm ²) | (mm ²) | (mm ²) | (g/set) | (nH/N ²) 1kHz 0.5mA | 100kHz 200mT | | |
| 0.464 | 74.6 | 161 | 12000 | 142 | 137 | 149.6 | 55 | 7000±25% | 25°C | 80°C | 120°C |
| | | | | | | | | | 5.30 | 4.45 | 5.30 |

* Coil : $\phi 0.4$ 2UEW 100Ts

○ Calculated output power (forward converter mode): 365W

NI limit vs. AL-value (Typ.)

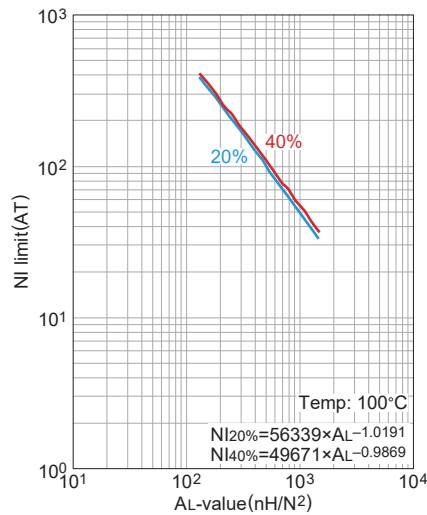

The 20% and 40% graph shows when a 20% and 40% drop from the initial AL-value has been made due to the DC superimposition.

AL-value vs. Air gap length (Typ.)

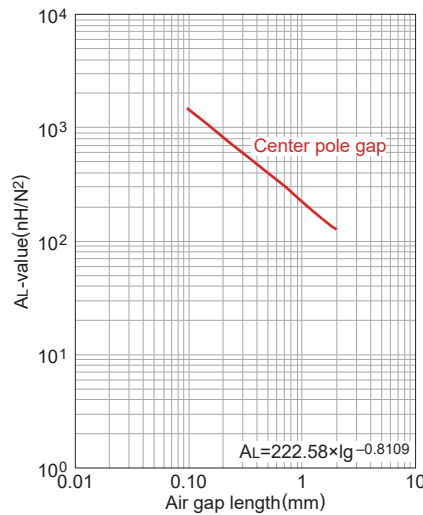

Measuring conditions

- Coil : $\phi 0.4$ 2UEW 100Ts
- Frequency : 1kHz
- Current level : 0.5mA
- Ambient temperature : 25°C

Temperature rise vs. Total loss (Typ.)

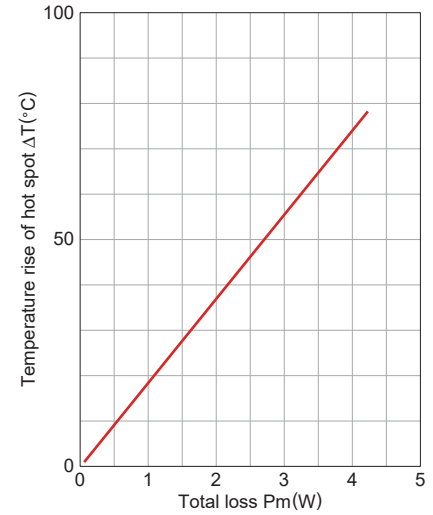

Measuring conditions

- Room space: approx. 400x300x 300cm
- Ambient temperature : 25°C
- Humidity: 45%(%)RH.

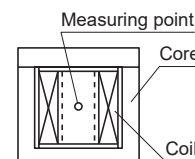

• All specifications are subject to change without notice.

Mn-Zn PQ series Part No.: PC47PQ35/35Z-12

SHAPES AND DIMENSIONS

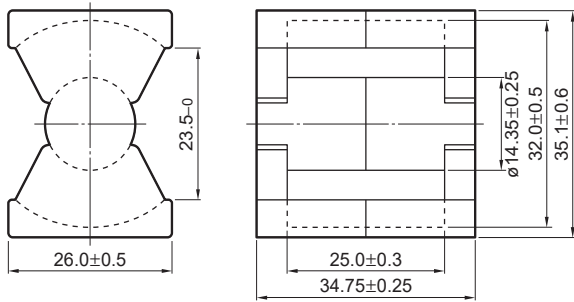

| Effective parameter | | | | | | | | Electrical characteristics | |
|------------------------------|--------------------------------------|--------------------------------------|-----------------------------|---|--|---|---------|---------------------------------------|-------------------------------------|
| Core factor | Effective magnetic path length l_e | Effective cross-sectional area A_e | Effective core volume V_e | Cross-sectional center pole area A_{cp} | Minimum cross-sectional center pole area $A_{cp \text{ min.}}$ | Cross-sectional winding area of core A_{cw} | Weight | AL-value * | Core loss |
| C_1 (mm ⁻¹) | (mm) | (mm ²) | (mm ³) | (mm ²) | (mm ²) | (mm ²) | (g/set) | (nH/N ²) 1kHz 0.5mA | (W)max. 100kHz 200mT 100°C |
| 0.448 | 87.9 | 196 | 17300 | 162 | 156 | 220.6 | 73 | 4860±25% | 4.98 |

* Coil : $\phi 0.4$ 2UEW 100Ts
 ○ Calculated output power (forward converter mode): 495W (100kHz)

NI limit vs. AL-value (Typ.)

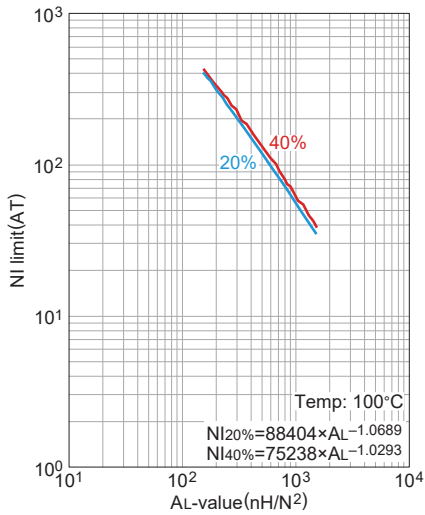

The 20% and 40% graph shows when a 20% and 40% drop from the initial AL-value has been made due to the DC superimposition.

AL-value vs. Air gap length (Typ.)

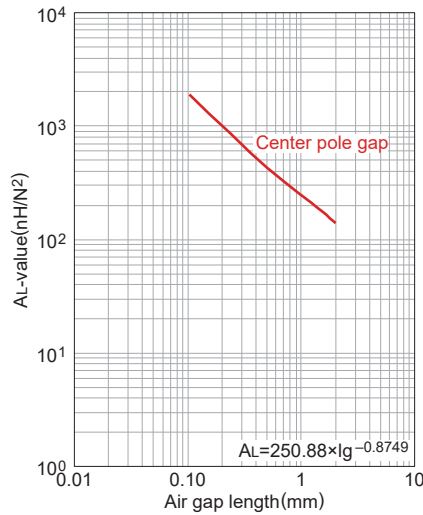

Measuring conditions
 • Coil : $\phi 0.4$ 2UEW 100Ts
 • Frequency : 1kHz
 • Current level : 0.5mA
 • Ambient temperature : 25°C

Temperature rise vs. Total loss (Typ.)

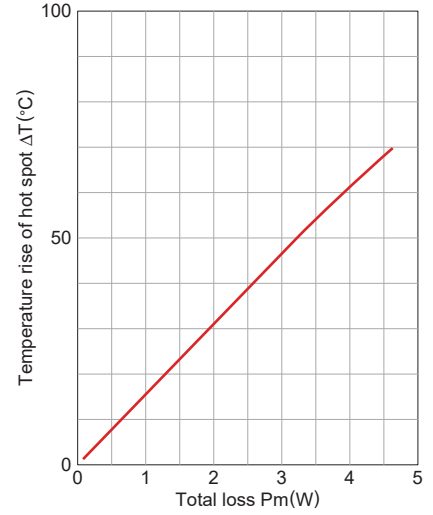

Measuring conditions
 • Room space: approx. 400x300x 300cm
 • Ambient temperature : 25°C
 • Humidity : 45%(%)RH.

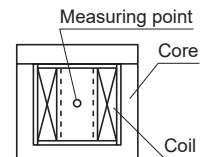

• All specifications are subject to change without notice.

Mn-Zn PQ series Part No.: PC90PQ35/35Z-12

SHAPES AND DIMENSIONS

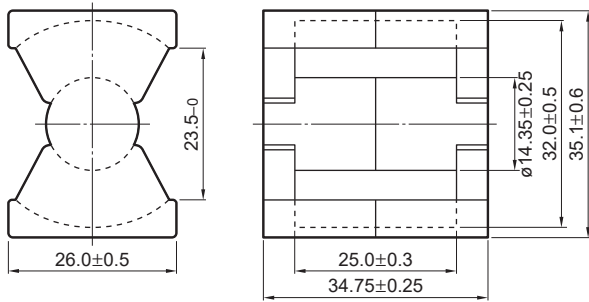

| Effective parameter | | | | | | | | Electrical characteristics | |
|------------------------|---|---|--|--|---|--|----------------|---------------------------------------|--------------------------------------|
| Core factor | Effective magnetic path length l_e (mm) | Effective cross-sectional area A_e (mm ²) | Effective core volume V_e (mm ³) | Cross-sectional center pole area A_{cp} (mm ²) | Minimum cross-sectional center pole area $A_{cp \text{ min.}}$ (mm ²) | Cross-sectional winding area of core A_{cw} (mm ²) | Weight (g/set) | AL-value * (nH/N ²) | Core loss (W)max. 100kHz 200mT 100°C |
| C1 (mm ⁻¹) | | | | | | | | (nH/N ²) 1kHz 0.5mA | |
| 0.448 | 87.9 | 196 | 17300 | 162 | 156 | 220.6 | 73 | 4700±25% | 6.6 |

* Coil : ø0.4 2UEW 100Ts
 ○ Calculated output power (forward converter mode): 476W

NI limit vs. AL-value (Typ.)

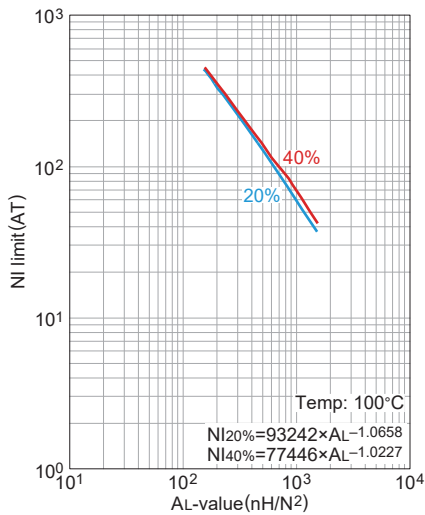

The 20% and 40% graph shows when a 20% and 40% drop from the initial AL-value has been made due to the DC superimposition.

AL-value vs. Air gap length (Typ.)

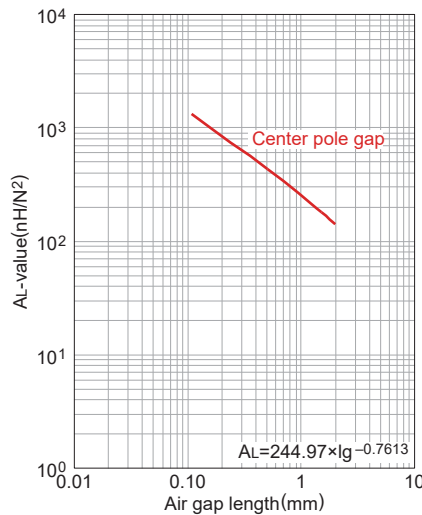

Measuring conditions
 • Coil : ø0.4 2UEW 100Ts
 • Frequency : 1kHz
 • Current level : 0.5mA
 • Ambient temperature : 25°C

Temperature rise vs. Total loss (Typ.)

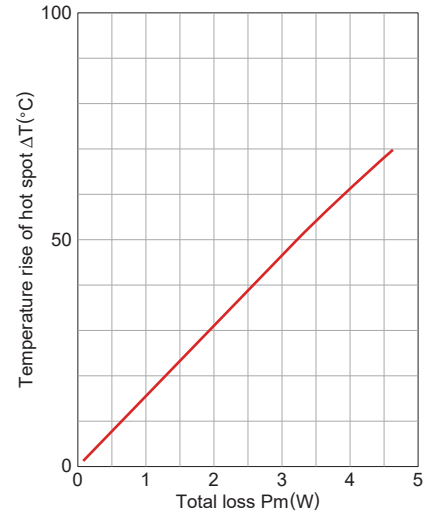

Measuring conditions
 • Room space: approx. 400x300x 300cm
 • Ambient temperature : 25°C
 • Humidity: 45%(%)RH.

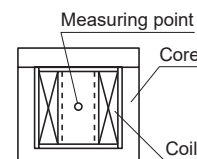

• All specifications are subject to change without notice.

Mn-Zn PQ series Part No.: PC95PQ35/35Z-12

SHAPES AND DIMENSIONS

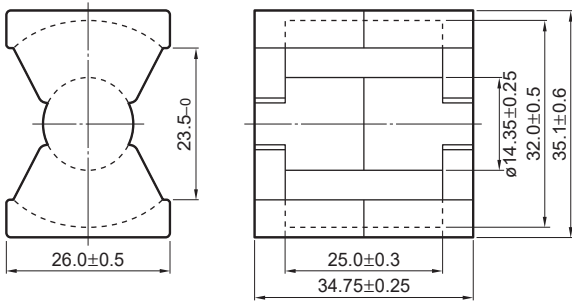

| Effective parameter | | | | | | | | Electrical characteristics | | | |
|---------------------|---|---|--|--|---|--|----------------|---------------------------------------|-------------------|------|-------|
| Core factor | Effective magnetic path length l_e (mm) | Effective cross-sectional area A_e (mm ²) | Effective core volume V_e (mm ³) | Cross-sectional center pole area A_{cp} (mm ²) | Minimum cross-sectional center pole area $A_{cp \text{ min.}}$ (mm ²) | Cross-sectional winding area of core A_{cw} (mm ²) | Weight (g/set) | AL-value * (nH/N ²) | Core loss (W)max. | | |
| C ₁ | (mm ⁻¹) | (mm) | (mm ³) | (mm ²) | (mm ²) | (mm ²) | (g/set) | (nH/N ²) 1kHz 0.5mA | 25°C | 80°C | 120°C |
| 0.448 | 87.9 | 196 | 17300 | 162 | 156 | 220.6 | 73 | 7320±25% | 7.12 | 5.98 | 7.12 |

* Coil : $\phi 0.4$ 2UEW 100Ts
 ○ Calculated output power (forward converter mode): 512W

NI limit vs. AL-value (Typ.)

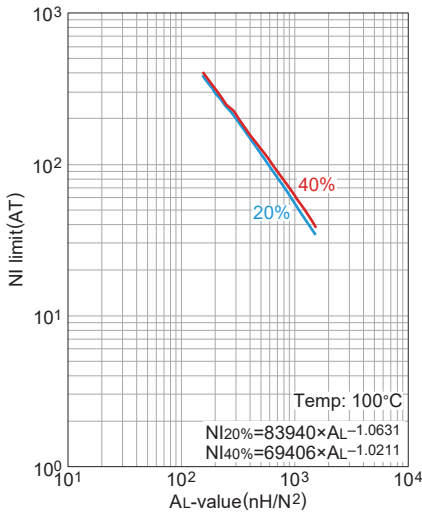

The 20% and 40% graph shows when a 20% and 40% drop from the initial AL-value has been made due to the DC superimposition.

AL-value vs. Air gap length (Typ.)

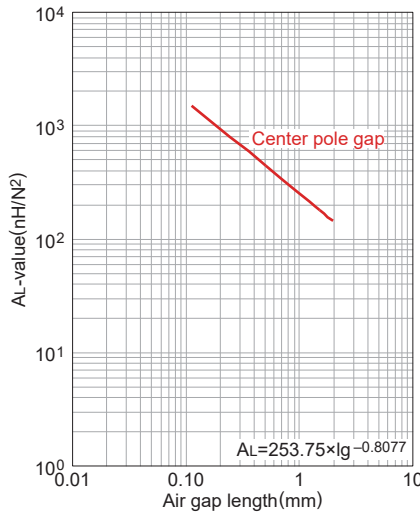

Measuring conditions
 • Coil : $\phi 0.4$ 2UEW 100Ts
 • Frequency : 1kHz
 • Current level : 0.5mA
 • Ambient temperature : 25°C

Temperature rise vs. Total loss (Typ.)

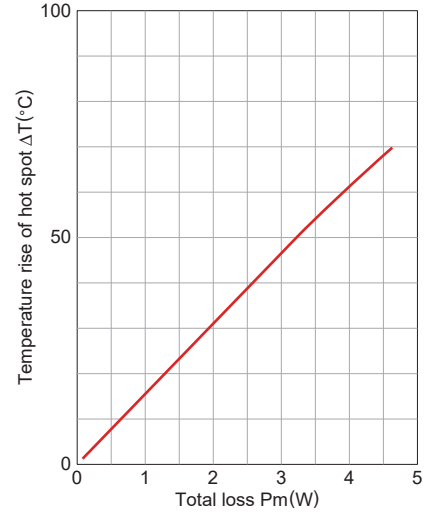

Measuring conditions
 • Room space: approx. 400x300x 300cm
 • Ambient temperature : 25°C
 • Humidity: 45%(%)RH.

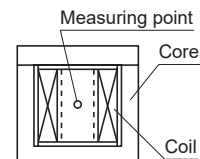

• All specifications are subject to change without notice.

Mn-Zn PQ series Part No.: PC47PQ40/40Z-12

SHAPES AND DIMENSIONS

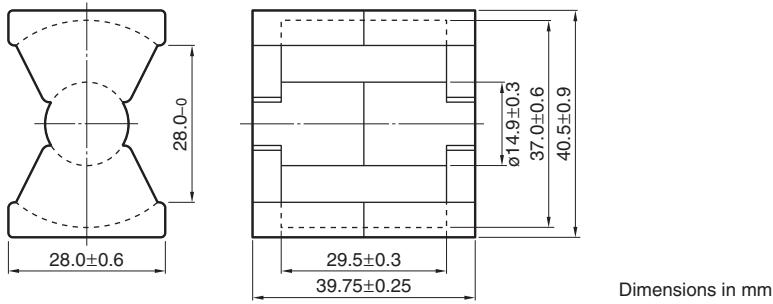

| Effective parameter | | | | | | | | Electrical characteristics | |
|---------------------|---|---|--|--|---|--|----------------|---------------------------------|------------------------------------|
| Core factor | Effective magnetic path length l_e (mm) | Effective cross-sectional area A_e (mm ²) | Effective core volume V_e (mm ³) | Cross-sectional center pole area A_{cp} (mm ²) | Minimum cross-sectional center pole area $A_{cp \text{ min.}}$ (mm ²) | Cross-sectional winding area of core A_{cw} (mm ²) | Weight (g/set) | AL-value * (nH/N ²) | Core loss (W)max. 1kHz 0.5mA 100°C |
| 0.508 | 102 | 201 | 20500 | 174 | 167 | 326 | 95 | 4300±25% | 6.21 |

* Coil : ø0.4 2UEW 100Ts
 ○ Calculated output power (forward converter mode): 708W (100kHz)

NI limit vs. AL-value (Typ.)

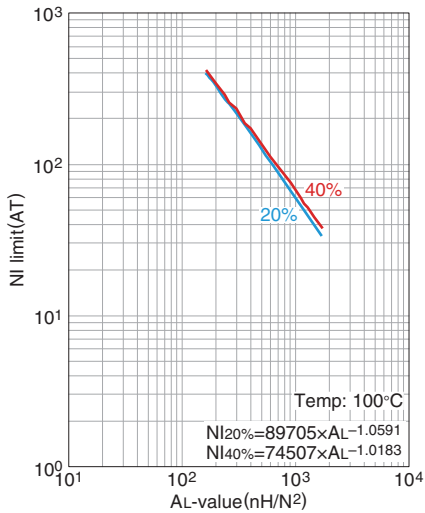

The 20% and 40% graph shows when a 20% and 40% drop from the initial AL-value has been made due to the DC superimposition.

AL-value vs. Air gap length (Typ.)

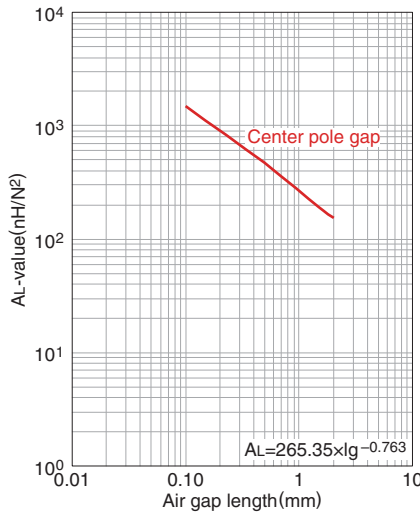

Measuring conditions
 • Coil : ø0.4 2UEW 100Ts
 • Frequency : 1kHz
 • Current level : 0.5mA
 • Ambient temperature : 25°C

Temperature rise vs. Total loss (Typ.)

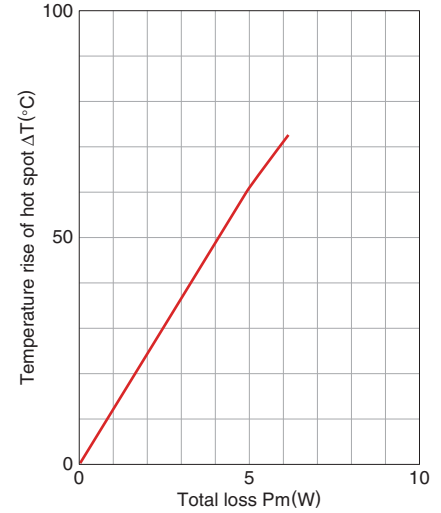

Measuring conditions
 • Room space: approx. 400x300x 300cm
 • Ambient temperature : 25°C
 • Humidity : 45%(%)RH.

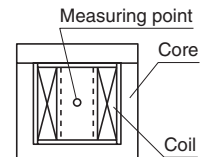

• All specifications are subject to change without notice.

Mn-Zn PQ series Part No.: PC90PQ40/40Z-12

SHAPES AND DIMENSIONS

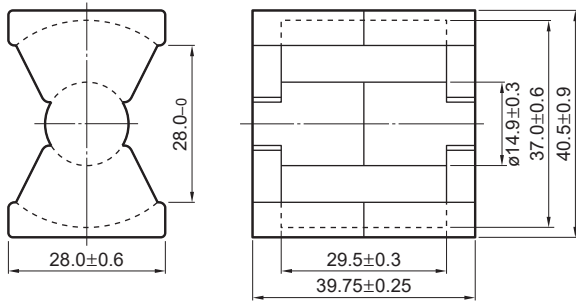

| Effective parameter | | | | | | | | Electrical characteristics | |
|---------------------|---|---|--|--|---|--|----------------|---------------------------------|------------------------------------|
| Core factor | Effective magnetic path length l_e (mm) | Effective cross-sectional area A_e (mm ²) | Effective core volume V_e (mm ³) | Cross-sectional center pole area A_{cp} (mm ²) | Minimum cross-sectional center pole area $A_{cp \text{ min.}}$ (mm ²) | Cross-sectional winding area of core A_{cw} (mm ²) | Weight (g/set) | AL-value * (nH/N ²) | Core loss (W)max. 1kHz 0.5mA 100°C |
| 0.508 | 102 | 201 | 20500 | 174 | 167 | 326 | 95 | 4300±25% | 8.2 |

* Coil : $\phi 0.4$ 2UEW 100Ts
 ○ Calculated output power (forward converter mode): 692W

NI limit vs. AL-value (Typ.)

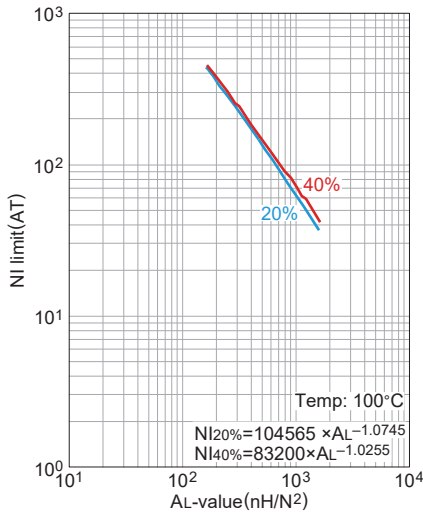

The 20% and 40% graph shows when a 20% and 40% drop from the initial AL-value has been made due to the DC superimposition.

AL-value vs. Air gap length (Typ.)

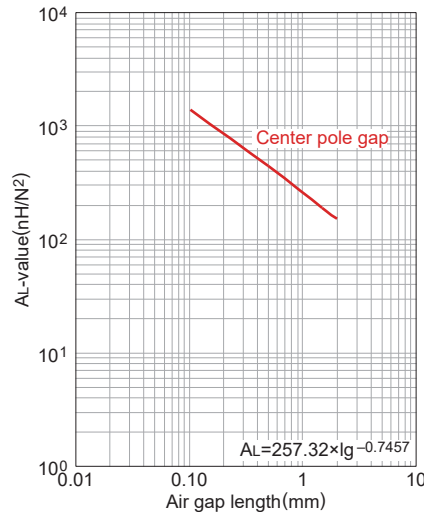

Measuring conditions

- Coil : $\phi 0.4$ 2UEW 100Ts
- Frequency : 1kHz
- Current level : 0.5mA
- Ambient temperature : 25°C

Temperature rise vs. Total loss (Typ.)

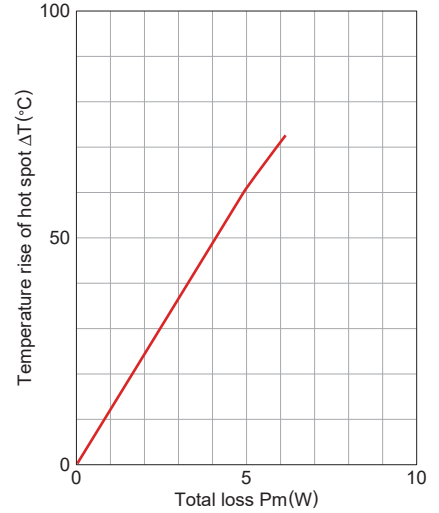

Measuring conditions

- Room space: approx. 400x300x 300cm
- Ambient temperature : 25°C
- Humidity : 45%(%)RH.

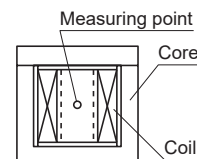

• All specifications are subject to change without notice.

Mn-Zn PQ series Part No.: PC95PQ40/40Z-12

SHAPES AND DIMENSIONS

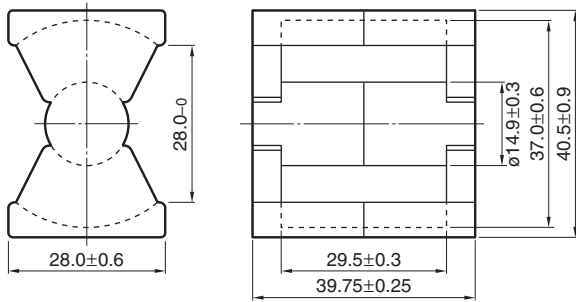

| Effective parameter | | | | | | | | Electrical characteristics | | | | |
|---------------------------|---|---|--|--|---|--|----------------|---------------------------------------|---|------|------|--|
| Core factor | Effective magnetic path length l_e (mm) | Effective cross-sectional area A_e (mm ²) | Effective core volume V_e (mm ³) | Cross-sectional center pole area A_{cp} (mm ²) | Minimum cross-sectional center pole area $A_{cp \text{ min.}}$ (mm ²) | Cross-sectional winding area of core A_{cw} (mm ²) | Weight (g/set) | AL-value * | Core loss | | | |
| C_1 (mm ⁻¹) | | | | | | | | (nH/N ²) 1kHz 0.5mA | (W)max. 100kHz 200mT 25°C 80°C 120°C | | | |
| 0.508 | 102 | 201 | 20500 | 174 | 167 | 326 | 95 | 6400±25% | 8.87 | 7.45 | 8.87 | |

* Coil : $\phi 0.4$ 2UEW 100Ts
 ○ Calculated output power (forward converter mode): 747W

NI limit vs. AL-value (Typ.)

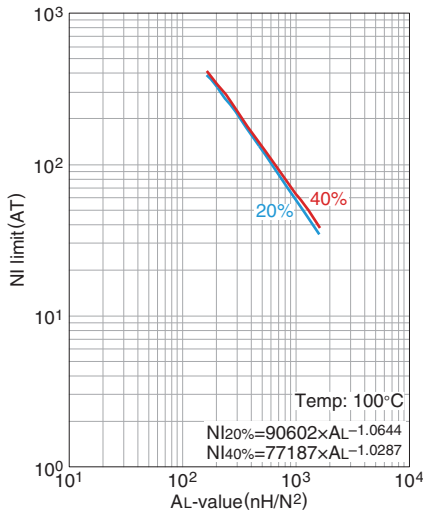

The 20% and 40% graph shows when a 20% and 40% drop from the initial AL-value has been made due to the DC superimposition.

AL-value vs. Air gap length (Typ.)

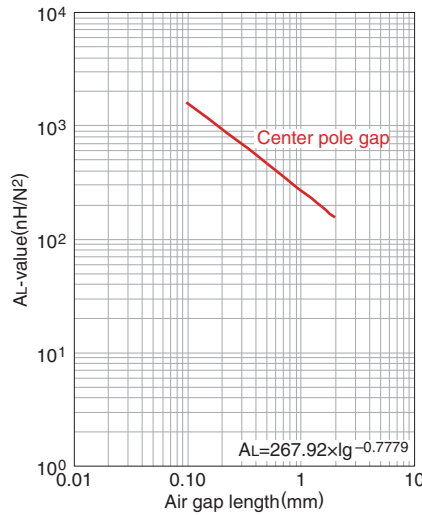

Measuring conditions
 • Coil : $\phi 0.4$ 2UEW 100Ts
 • Frequency : 1kHz
 • Current level : 0.5mA
 • Ambient temperature : 25°C

Temperature rise vs. Total loss (Typ.)

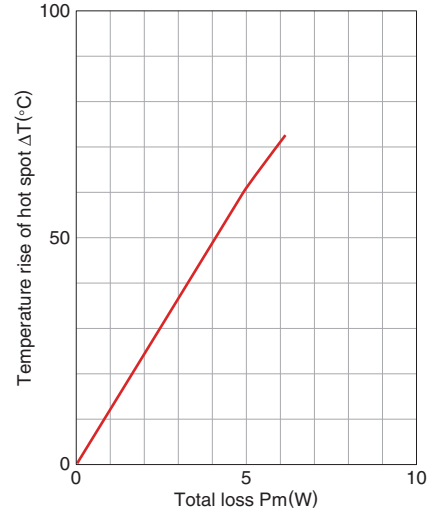

Measuring conditions
 • Room space: approx. 400x300x 300cm
 • Ambient temperature : 25°C
 • Humidity: 45(%)RH.

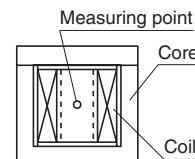

• All specifications are subject to change without notice.

Mn-Zn PQ series Part No.: PC47PQ50/50Z-12

SHAPES AND DIMENSIONS

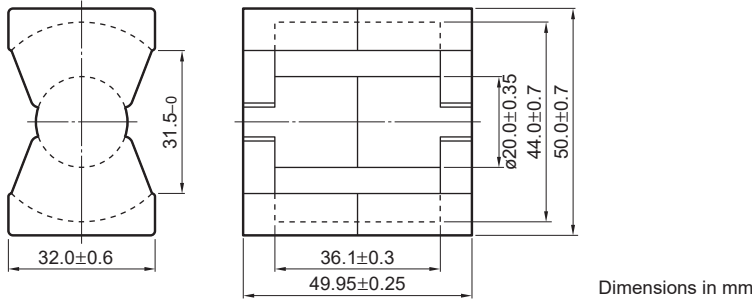

| Effective parameter | | | | | | | | Electrical characteristics | |
|---------------------|---|---|--|--|---|--|----------------|---------------------------------|--------------------------------------|
| Core factor | Effective magnetic path length l_e (mm) | Effective cross-sectional area A_e (mm ²) | Effective core volume V_e (mm ³) | Cross-sectional center pole area A_{cp} (mm ²) | Minimum cross-sectional center pole area $A_{cp \text{ min.}}$ (mm ²) | Cross-sectional winding area of core A_{cw} (mm ²) | Weight (g/set) | AL-value * (nH/N ²) | Core loss (W)max. 100kHz 200mT 100°C |
| 0.346 | 113 | 328 | 37200 | 314 | 303 | 433 | 195 | 6720±25% | 15.26 |

* Coil : ø0.4 2UEW 100Ts
 ○ Calculated output power (forward converter mode): 1046W (100kHz)

NI limit vs. AL-value (Typ.)

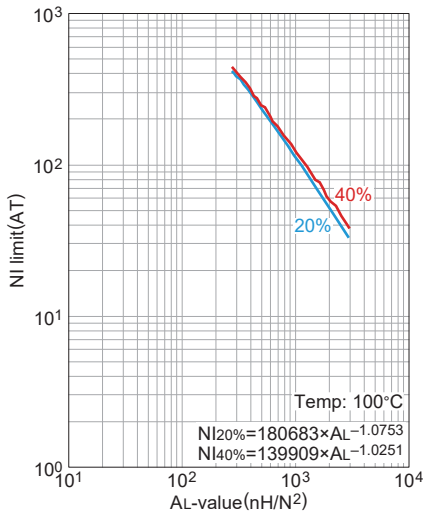

The 20% and 40% graph shows when a 20% and 40% drop from the initial AL-value has been made due to the DC superimposition.

AL-value vs. Air gap length (Typ.)

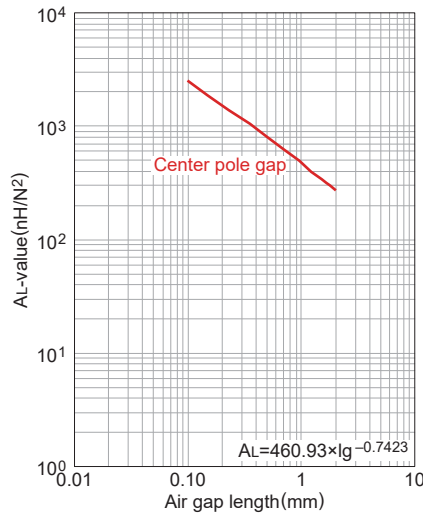

Measuring conditions
 • Coil : ø0.4 2UEW 100Ts
 • Frequency : 1kHz
 • Current level : 0.5mA
 • Ambient temperature : 25°C

Temperature rise vs. Total loss (Typ.)

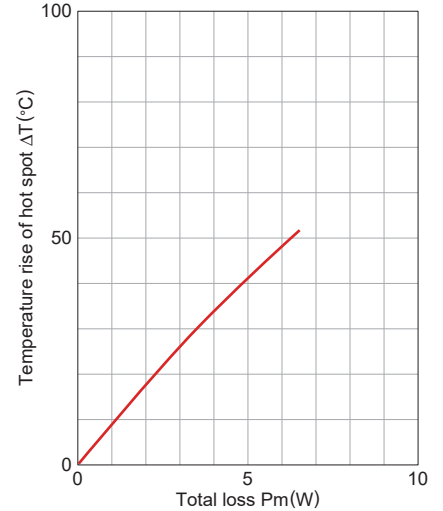

Measuring conditions
 • Room space: approx. 400x300x 300cm
 • Ambient temperature : 25°C
 • Humidity: 45%(%)RH.

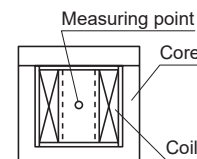

• All specifications are subject to change without notice.

Mn-Zn PQ series Part No.: PC90PQ50/50Z-12

SHAPES AND DIMENSIONS

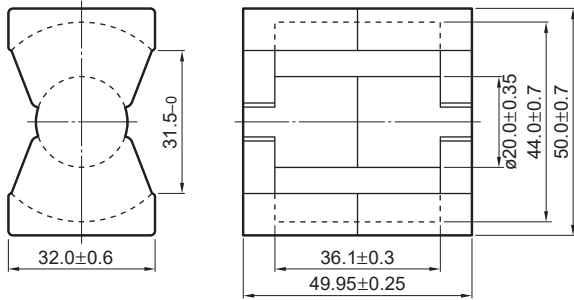

Dimensions in mm

| Effective parameter | | | | | | | | Electrical characteristics | |
|------------------------------|--------------------------------------|--------------------------------------|-----------------------------|---|--|---|---------|---------------------------------------|-------------------------------------|
| Core factor | Effective magnetic path length l_e | Effective cross-sectional area A_e | Effective core volume V_e | Cross-sectional center pole area A_{cp} | Minimum cross-sectional center pole area $A_{cp \text{ min.}}$ | Cross-sectional winding area of core A_{cw} | Weight | AL-value * | Core loss |
| C_1 (mm ⁻¹) | (mm) | (mm ²) | (mm ³) | (mm ²) | (mm ²) | (mm ²) | (g/set) | (nH/N ²) 1kHz 0.5mA | (W)max. 100kHz 200mT 100°C |
| 0.346 | 113 | 328 | 37200 | 314 | 303 | 433 | 195 | 6250±25% | 8.4 |

* Coil : ø0.4 2UEW 100Ts

○ Calculated output power (forward converter mode): 1045W

NI limit vs. AL-value (Typ.)

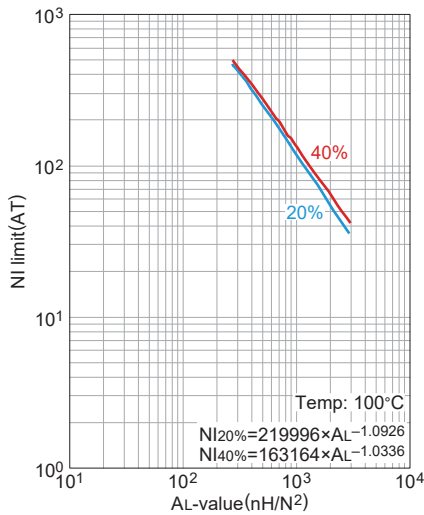

The 20% and 40% graph shows when a 20% and 40% drop from the initial AL-value has been made due to the DC superimposition.

AL-value vs. Air gap length (Typ.)

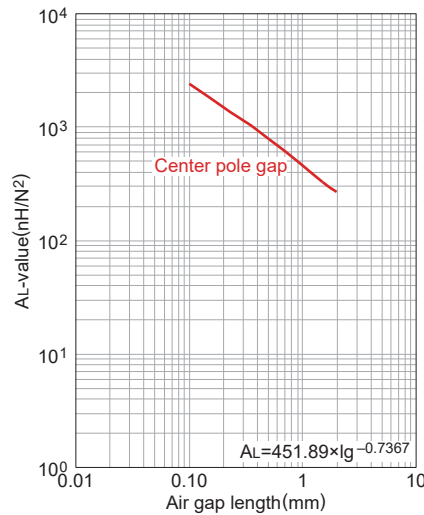

Measuring conditions

- Coil : ø0.4 2UEW 100Ts
- Frequency : 1kHz
- Current level : 0.5mA
- Ambient temperature : 25°C

Temperature rise vs. Total loss (Typ.)

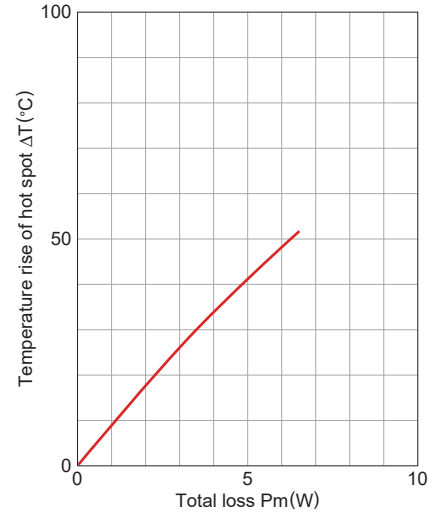

Measuring conditions

- Room space: approx. 400x300x 300cm
- Ambient temperature : 25°C
- Humidity: 45(%)RH.

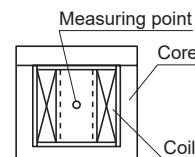

All specifications are subject to change without notice.

Mn-Zn PQ series Part No.: PC95PQ50/50Z-12

SHAPES AND DIMENSIONS

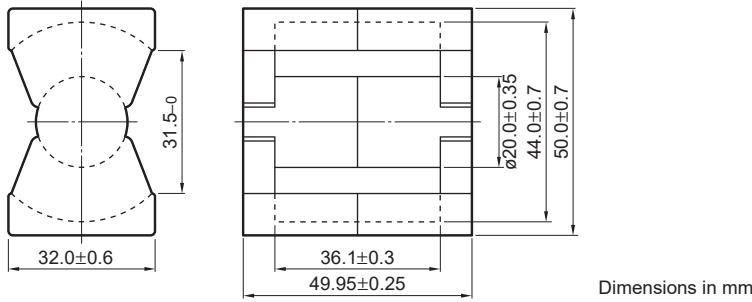

| Effective parameter | | | | | | | | Electrical characteristics | | | |
|---------------------|---|---|--|--|---|--|----------------|---------------------------------------|-------------------|------|-------|
| Core factor | Effective magnetic path length l_e (mm) | Effective cross-sectional area A_e (mm ²) | Effective core volume V_e (mm ³) | Cross-sectional center pole area A_{cp} (mm ²) | Minimum cross-sectional center pole area $A_{cp \text{ min.}}$ (mm ²) | Cross-sectional winding area of core A_{cw} (mm ²) | Weight (g/set) | AL-value * (nH/N ²) | Core loss (W)max. | | |
| C ₁ | (mm ⁻¹) | (mm) | (mm ³) | (mm ²) | (mm ²) | (mm ²) | (g/set) | (nH/N ²) 1kHz 0.5mA | 25°C | 80°C | 120°C |
| 0.346 | 113 | 328 | 37200 | 314 | 303 | 433 | 195 | 9700±25% | 9.00 | 7.50 | 9.00 |

* Coil : ø0.4 2UEW 100Ts
 ○ Calculated output power (forward converter mode): 1078W

NI limit vs. AL-value (Typ.)

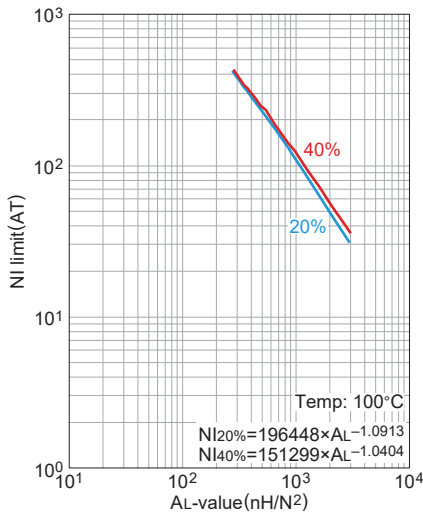

The 20% and 40% graph shows when a 20% and 40% drop from the initial AL-value has been made due to the DC superimposition.

AL-value vs. Air gap length (Typ.)

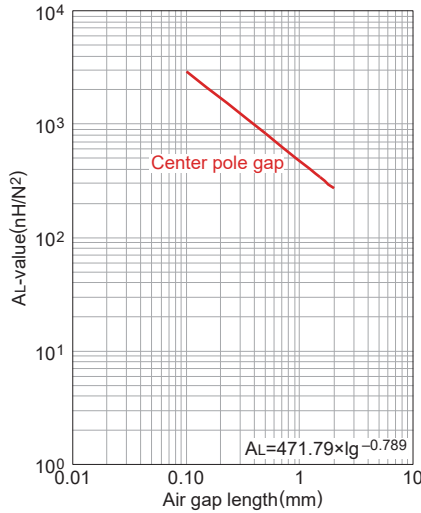

Measuring conditions
 • Coil : ø0.4 2UEW 100Ts
 • Frequency : 1kHz
 • Current level : 0.5mA
 • Ambient temperature : 25°C

Temperature rise vs. Total loss (Typ.)

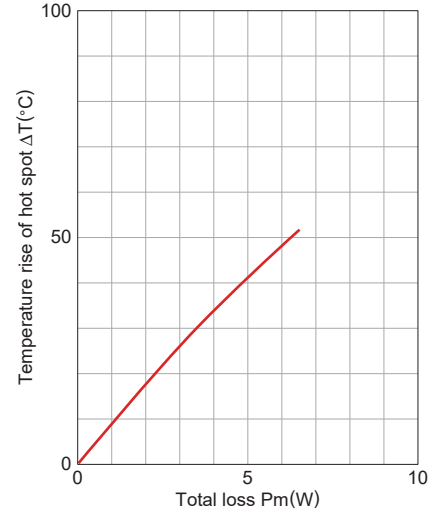

Measuring conditions
 • Room space: approx. 400x300x 300cm
 • Ambient temperature : 25°C
 • Humidity : 45(%)RH.

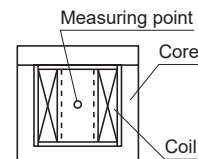

• All specifications are subject to change without notice.

Mn-Zn

Ferrite Cores for Switching Power Supplies

RM series

 **REMINDERS FOR USING THESE PRODUCTS**

Please be sure to read this manual thoroughly before using the products.

The products listed on this catalog are intended for use in general electronic equipment (AV equipment, telecommunications equipment, home appliances, amusement equipment, computer equipment, personal equipment, office equipment, measurement equipment, industrial robots) under a normal operation and use condition.

The products are not designed or warranted to meet the requirements of the applications listed below, whose performance and/or quality require a more stringent level of safety or reliability, or whose failure, malfunction or trouble could cause serious damage to society, person or property.

When using the products for specific purposes, please first make confirmations in areas such as safety, reliability, and quality.

Please understand that we are not in a position to be held responsible for any damage or the like caused by any use exceeding the range or conditions of this specification sheet or by any use in the specific applications.

- | | |
|---|--|
| (1) Aerospace/Aviation equipment | (8) Public information-processing equipment |
| (2) Transportation equipment (electric trains, ships, etc.) | (9) Military equipment |
| (3) Medical equipment | (10) Electric heating apparatus, burning equipment |
| (4) Power-generation control equipment | (11) Disaster prevention/crime prevention equipment |
| (5) Atomic energy-related equipment | (12) Safety equipment |
| (6) Seabed equipment | (13) Other applications that are not considered general-purpose applications |
| (7) Transportation control equipment | |

When using this product in general-purpose standard applications, you are kindly requested to take into consideration securing protection circuit/equipment or providing backup circuits, etc to ensure higher safety.

Ferrite Cores for Switching Power Supplies

Product compatible with RoHS directive
Halogen-free

Overview of the RM Series

FEATURES

The RM Cores has a shape that is suited to high density mounting, it possesses good shielding qualities, being laid out so that the lead groove does not create an obstruction, and enables the creation of small, high performance transformers and coils.

APPLICATION

Transformers and coils for Switched-mode power supplies (High Mounting Density, Low Profile)

PART NUMBER CONSTRUCTION

| | | | | | |
|-----------------|------------------------|--|---|-------------|----------------------------|
| PC47 | RM4 | Z | - | 1 | 2 |
| Material | Size of RM core | AL-value (Z: without air gap) | | Type | Number of lead slot |
| PC47 | RM4 | | | | |
| | RM5 | | | | |
| | RM6 | | | | |
| | RM8 | | | | |
| | RM10 | | | | |
| | RM12 | | | | |
| | RM14 | | | | |

RANGE OF USE AND STORAGE TEMPERATURE

| Temperature range | |
|----------------------------|--------------------------|
| Operating temperature (°C) | Storage temperature (°C) |
| -30 to +105 | -30 to +85 |

○ RoHS Directive Compliant Product: See the following for more details. <https://product.tdk.com/info/en/environment/rohs/index.html>

○ Halogen-free: Indicates that Cl content is less than 900ppm, Br content is less than 900ppm, and that the total Cl and Br content is less than 1500ppm.

⚠ Please be sure to request delivery specifications that provide further details on the features and specifications of the products for proper and safe use. Please note that the contents may change without any prior notice due to reasons such as upgrading.

Mn-Zn RM Cores

SHAPES AND DIMENSIONS

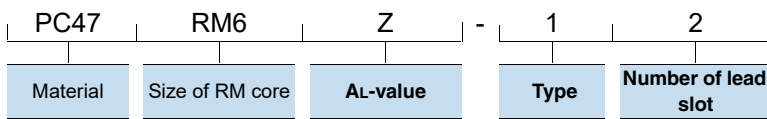
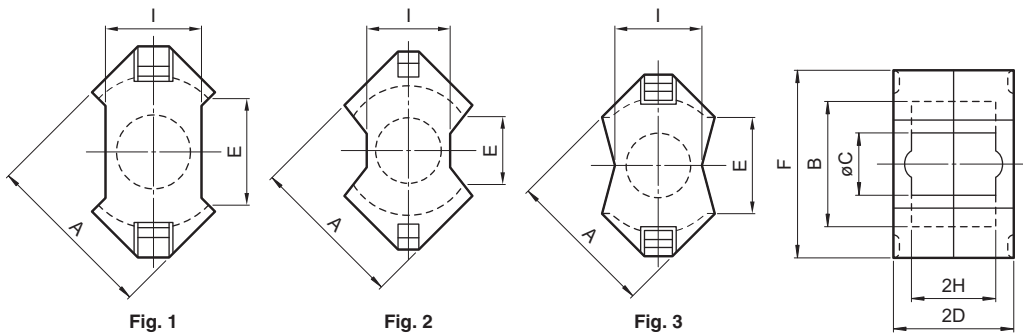

| Part No. | Core | Dimensions (mm) | | | | | | | |
|--------------|-------|-----------------|------------|------------|----------|--------|------------|----------|------------|
| | | A | B | øC | 2D | E min. | F | 2H | I |
| PC47RM4Z-12 | Fig.1 | 9.63±0.18 | 8.15±0.2 | 3.8±0.1 | 10.4±0.1 | 5.8 | 10.8±0.2 | 7.2±0.2 | 4.45±0.15 |
| PC47RM5Z-12 | Fig.1 | 12.05±0.25 | 10.4±0.2 | 4.8±0.1 | 10.4±0.1 | 6.0 | 14.3±0.3 | 6.5±0.2 | 6.6±0.2 |
| PC47RM6Z-12 | Fig.3 | 14.4±0.3 | 12.65±0.25 | 6.3±0.1 | 12.4±0.1 | 8.4 | 17.6±0.3 | 8.2±0.2 | 8.0±0.2 |
| PC47RM8Z-12 | Fig.2 | 19.35±0.35 | 17.3±0.3 | 8.4±0.15 | 16.4±0.1 | 9.8 | 22.75±0.45 | 11.0±0.2 | 10.8±0.2 |
| PC47RM10Z-12 | Fig.2 | 24.15±0.55 | 21.65±0.45 | 10.7±0.2 | 18.6±0.1 | 11.3 | 27.85±0.65 | 12.7±0.3 | 13.25±0.25 |
| PC47RM12Z-12 | Fig.2 | 29.25±0.55 | 25.5±0.5 | 12.6±0.2 | 23.5±0.1 | 12.9 | 36.75±0.65 | 17.1±0.3 | 16.0±0.3 |
| PC47RM14Z-12 | Fig.1 | 34.2±0.5 | 29.5±0.5 | 14.75±0.25 | 28.8±0.2 | 17.0 | 41.6±0.6 | 21.1±0.3 | 18.7±0.3 |

| Part No. | Effective parameter | | | | | Electrical characteristics | | |
|--------------|-----------------------|--------------------------------|--------------------------------|-----------------------|--------|--|----------------------------|--------------------------------------|
| | Core factor | Effective cross-sectional area | Effective magnetic path length | Effective core volume | Weight | AL-value | | Core loss |
| | $C_1(\text{mm}^{-1})$ | $A_e(\text{mm}^2)$ | $\ell_e(\text{mm})$ | $V_e(\text{mm}^3)$ | (g) | (nH/N ²) 1kHz 0.5mA 100Ts | | (W) max. 100kHz 200mT 100°C |
| PC47RM4Z-12 | 1.62 | 14.0 | 22.7 | 318 | 1.7 | 680 min. | Without air gap | 0.11 |
| PC47RM5Z-12 | 0.940 | 23.7 | 22.4 | 530 | 3.0 | 1250 min. | With air gap | 0.17 |
| PC47RM6Z-12 | 0.781 | 36.6 | 28.6 | 1050 | 5.5 | 2450±25% | 63±3% 100±3% 160±3% | 0.38 |
| PC47RM8Z-12 | 0.594 | 64.0 | 38.0 | 2430 | 13 | 1950 min. | 100±3% 160±3% 250±3% | 0.91 |
| PC47RM10Z-12 | 0.450 | 98.0 | 44.0 | 4310 | 23 | 4850±25% | 160±3% 250±3% 400±3% | 1.70 |
| PC47RM12Z-12 | 0.406 | 140 | 56.9 | 7970 | 42 | 4150 min. | 160±3% 250±3% 400±3% | 3.00 |
| PC47RM14Z-12 | 0.393 | 178 | 70.0 | 12500 | 70 | 4600 min. | 160±3% 250±3% 400±3% | 4.60 |

⚠ Please be sure to request delivery specifications that provide further details on the features and specifications of the products for proper and safe use. Please note that the contents may change without any prior notice due to reasons such as upgrading.

Mn-Zn RM series Part No.: PC47RM4Z-12

SHAPES AND DIMENSIONS

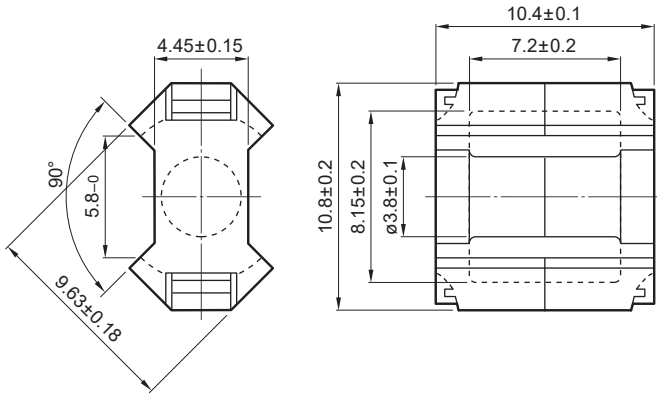

Dimensions in mm

Based on JIS C 2516, IEC Publication 60431 and DIN 41980.

| Effective parameter | | | | | | | | Electrical characteristics | | |
|-------------------------------|--------------------------------------|--------------------------------------|-----------------------------|---|--|---|---------|--------------------------------------|-----------------|-------------------------------------|
| Core factor | Effective magnetic path length l_e | Effective cross-sectional area A_e | Effective core volume V_e | Cross-sectional center pole area A_{cp} | Minimum cross-sectional center pole area $A_{cp \text{ min.}}$ | Cross-sectional winding area of core A_{cw} | Weight | AL-value * | | Core loss |
| C_1 (mm^{-1}) | (mm) | (mm^2) | (mm^3) | (mm^2) | (mm^2) | (mm^2) | (g/set) | (nH/N^2) 1kHz 0.5mA | 100kHz 200mT | (W)max. 100kHz 200mT 100°C |
| 1.62 | 22.7 | 14.0 | 318 | 11.3 | 10.7 | 15.6 | 1.7 | 680 min. | 1650 min. | 0.11 |

* Coil : $\phi 0.18$ 2UEW 100Ts

○ Calculated output power (forward converter mode): 8.4W (100kHz)

NI limit vs. AL-value (Typ.)

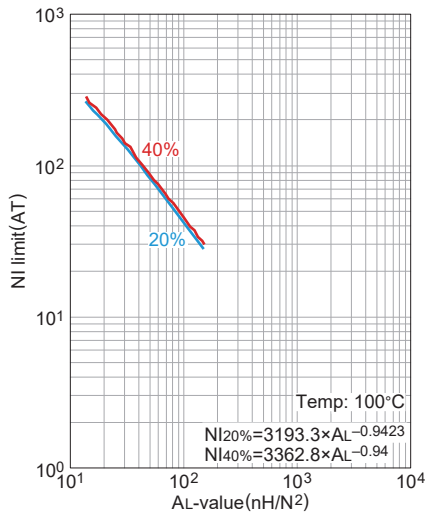

The 20% and 40% graph shows when a 20% and 40% drop from the initial AL-value has been made due to the DC superimposition.

AL-value vs. Air gap length (Typ.)

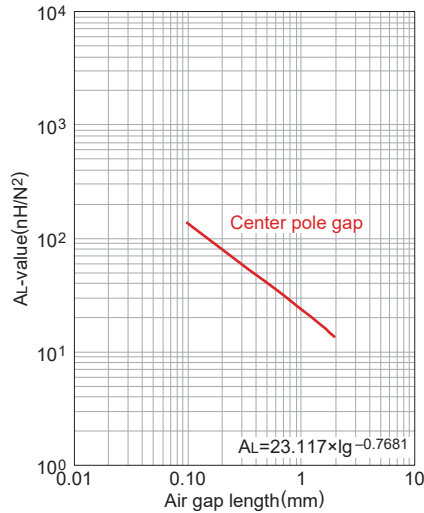

Measuring conditions

- Coil : $\phi 0.18$ 2UEW 100Ts
- Frequency : 1kHz
- Current level : 0.5mA
- Ambient temperature : 25°C

Temperature rise vs. Total loss (Typ.)

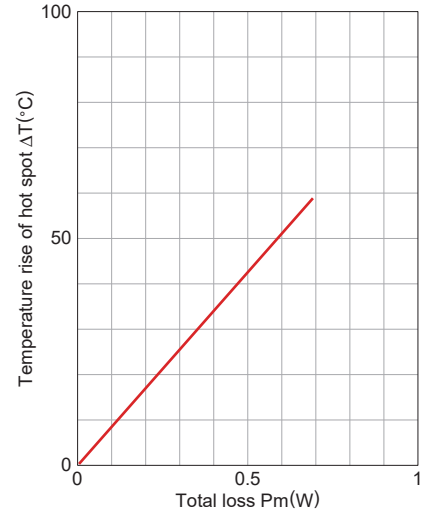

Measuring conditions

- Room space: approx. 400x300x 300cm
- Ambient temperature : 25°C
- Humidity: 45%(%)RH.

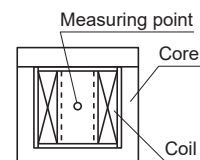

⚠ Please be sure to request delivery specifications that provide further details on the features and specifications of the products for proper and safe use. Please note that the contents may change without any prior notice due to reasons such as upgrading.

Mn-Zn RM series Part No.: PC47RM5Z-12

SHAPES AND DIMENSIONS

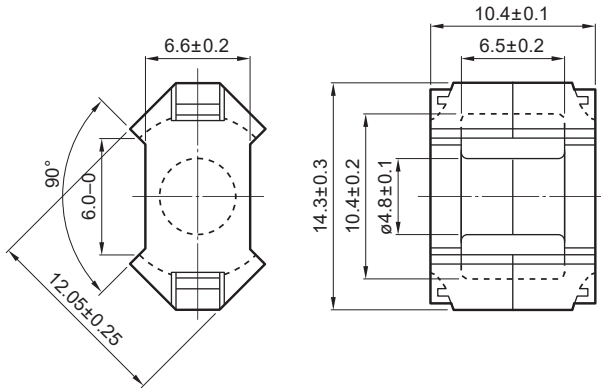

Dimensions in mm

Based on JIS C 2516, IEC Publication 60431 and DIN 41980.

| Effective parameter | | | | | | | | Electrical characteristics | | |
|-------------------------------|--------------------------------------|--------------------------------------|-----------------------------|---|--|---|---------|--------------------------------------|-----------------|-------------------------------------|
| Core factor | Effective magnetic path length l_e | Effective cross-sectional area A_e | Effective core volume V_e | Cross-sectional center pole area A_{cp} | Minimum cross-sectional center pole area $A_{cp \text{ min.}}$ | Cross-sectional winding area of core A_{cw} | Weight | AL-value * | | Core loss |
| C_1 (mm^{-1}) | (mm) | (mm^2) | (mm^3) | (mm^2) | (mm^2) | (mm^2) | (g/set) | (nH/N^2) 1kHz 0.5mA | 100kHz 200mT | (W)max. 100kHz 200mT 100°C |
| 0.940 | 22.4 | 23.7 | 530 | 18.1 | 17.3 | 18.2 | 3.0 | 1250 min. | 3340 min. | 0.17 |

* Coil : $\phi 0.2$ 2UEW 100Ts

○ Calculated output power (forward converter mode): 20.3W (100kHz)

NI limit vs. AL-value (Typ.)

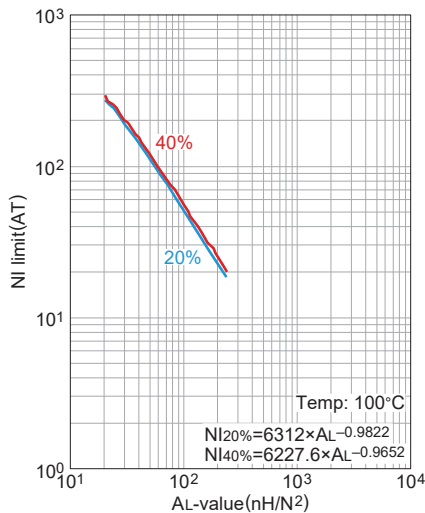

The 20% and 40% graph shows when a 20% and 40% drop from the initial AL-value has been made due to the DC superimposition.

AL-value vs. Air gap length (Typ.)

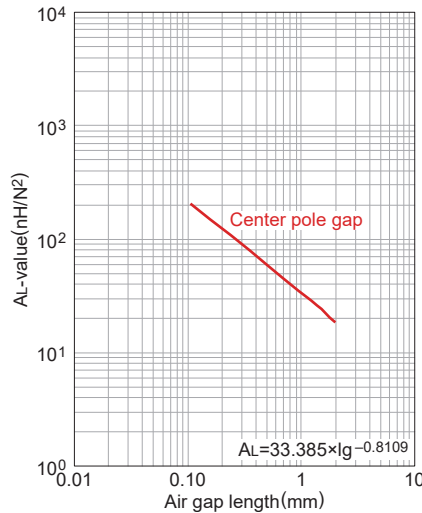

Measuring conditions
 • Coil : $\phi 0.2$ 2UEW 100Ts
 • Frequency : 1kHz
 • Current level : 0.5mA
 • Ambient temperature : 25°C

Temperature rise vs. Total loss (Typ.)

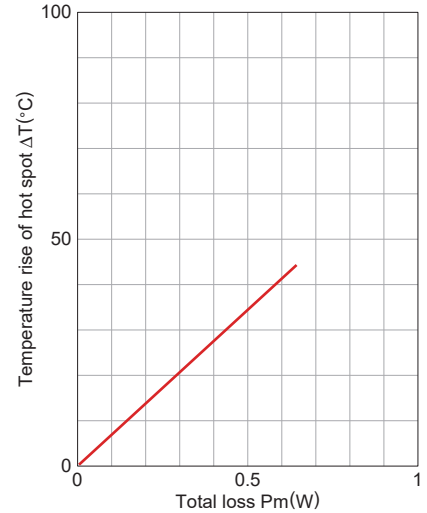

Measuring conditions
 • Room space: approx. 400x300x 300cm
 • Ambient temperature : 25°C
 • Humidity: 45%(%)RH.

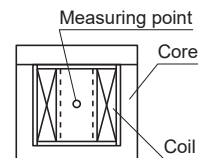

⚠ Please be sure to request delivery specifications that provide further details on the features and specifications of the products for proper and safe use. Please note that the contents may change without any prior notice due to reasons such as upgrading.

Mn-Zn RM series Part No.: PC47RM6Z-12

SHAPES AND DIMENSIONS

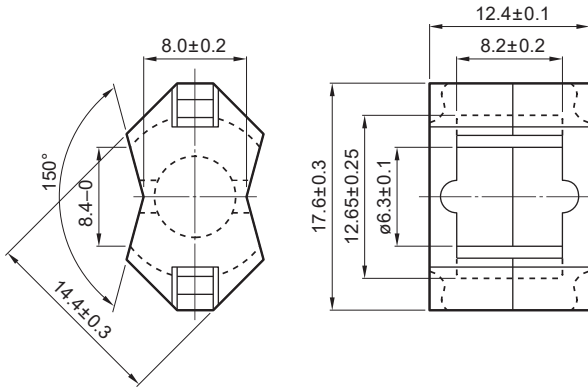

Dimensions in mm

Based on JIS C 2516, IEC Publication 60431 and DIN 41980.

| Effective parameter | | | | | | | | Electrical characteristics | | |
|---------------------|--------------------------------------|--------------------------------------|-----------------------------|---|--|---|---------|----------------------------|-----------------|--------------------------|
| Core factor | Effective magnetic path length l_e | Effective cross-sectional area A_e | Effective core volume V_e | Cross-sectional center pole area A_{cp} | Minimum cross-sectional center pole area $A_{cp \text{ min.}}$ | Cross-sectional winding area of core A_{cw} | Weight | AL-value * | | Core loss |
| C_1 | (mm) | (mm ²) | (mm ³) | (mm ²) | (mm ²) | (mm ²) | (g/set) | (nH/N ²) | | (W)max. |
| 0.781 | 28.6 | 36.6 | 1050 | 31.2 | 30.2 | 26.0 | 5.5 | 1kHz 0.5mA | 100kHz 200mT | 100kHz 200mT 100°C |
| | | | | | | | | 2450±25% | 4030 min. | 0.38 |

* Coil : ø0.26 2UEW 100Ts

○ Calculated output power (forward converter mode): 36.2W (100kHz)

NI limit vs. AL-value (Typ.)

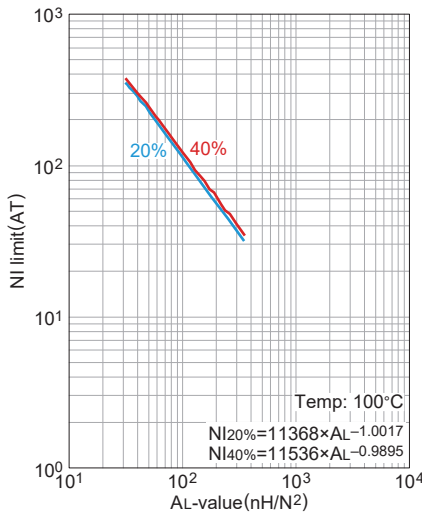

The 20% and 40% graph shows when a 20% and 40% drop from the initial AL-value has been made due to the DC superimposition.

AL-value vs. Air gap length (Typ.)

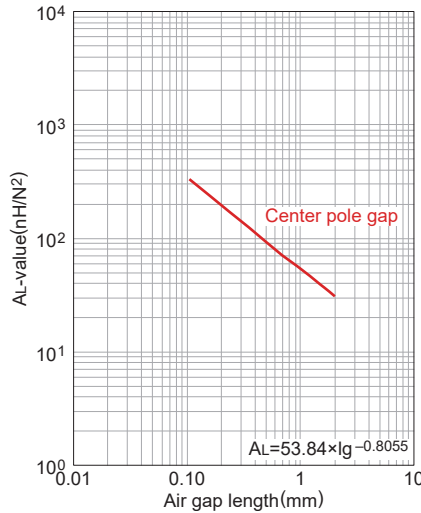

Measuring conditions

- Coil : ø0.26 2UEW 100Ts
- Frequency : 1kHz
- Current level : 0.5mA
- Ambient temperature : 25°C

Temperature rise vs. Total loss (Typ.)

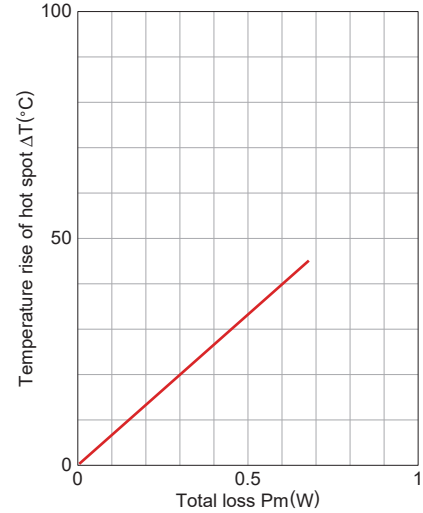

Measuring conditions

- Room space: approx. 400x300x 300cm
- Ambient temperature : 25°C
- Humidity: 45%(%)RH.

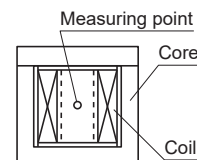

⚠ Please be sure to request delivery specifications that provide further details on the features and specifications of the products for proper and safe use. Please note that the contents may change without any prior notice due to reasons such as upgrading.

Mn-Zn RM series Part No.: PC47RM8Z-12

SHAPES AND DIMENSIONS

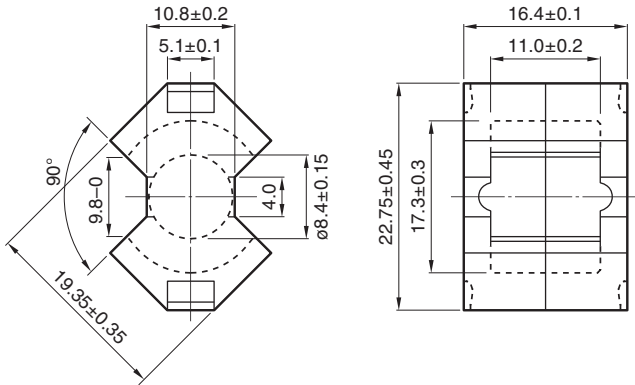

Dimensions in mm

Based on JIS C 2516, IEC Publication 60431 and DIN 41980.

| Effective parameter | | | | | | | | Electrical characteristics | | |
|--|--|--|---|---|--|---|-------------------|---------------------------------------|-----------------|-------------------------------------|
| Core factor C ₁ (mm ⁻¹) | Effective magnetic path length l _e (mm) | Effective cross-sectional area A _e (mm ²) | Effective core volume V _e (mm ³) | Cross-sectional center pole area A _{cp} (mm ²) | Minimum cross-sectional center pole area A _{cp min.} (mm ²) | Cross-sectional winding area of core A _{cw} (mm ²) | Weight (g/set) | AL-value * | | Core loss |
| 0.594 | 38.0 | 64.0 | 2430 | 55.4 | 53.5 | 48.9 | 13 | (nH/N ²) 1kHz 0.5mA | 100kHz 200mT | (W)max. 100kHz 200mT 100°C |
| | | | | | | | | 1950 min. | 5290 min. | 0.91 |

* Coil : ø0.4 2UEW 100Ts

○ Calculated output power (forward converter mode): 92.4W (100kHz)

NI limit vs. AL-value (Typ.)

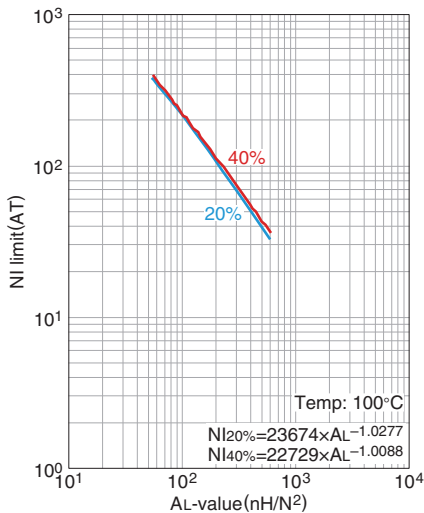

The 20% and 40% graph shows when a 20% and 40% drop from the initial AL-value has been made due to the DC superimposition.

AL-value vs. Air gap length (Typ.)

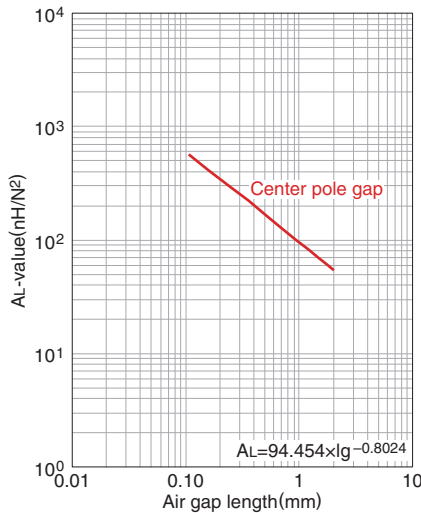

Measuring conditions

- Coil : ø0.4 2UEW 100Ts
- Frequency : 1kHz
- Current level : 0.5mA
- Ambient temperature : 25°C

Temperature rise vs. Total loss (Typ.)

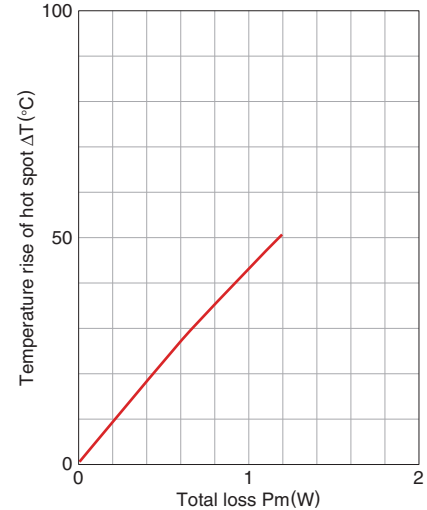

Measuring conditions

- Room space: approx. 400x300x 300cm
- Ambient temperature : 25°C
- Humidity: 45(%)RH.

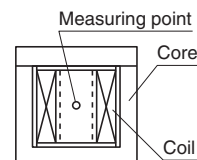

⚠ Please be sure to request delivery specifications that provide further details on the features and specifications of the products for proper and safe use. Please note that the contents may change without any prior notice due to reasons such as upgrading.

Mn-Zn RM series Part No.: PC47RM10Z-12

SHAPES AND DIMENSIONS

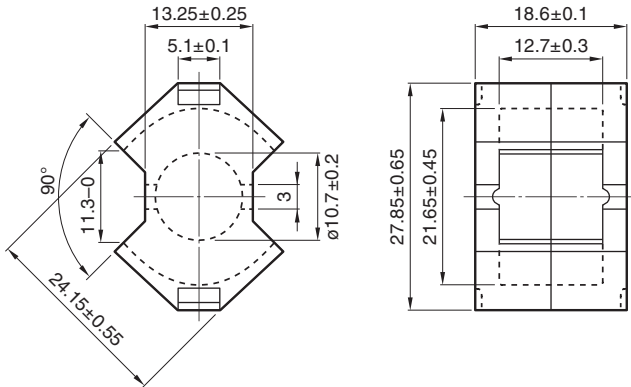

Dimensions in mm

Based on JIS C 2516, IEC Publication 60431 and DIN 41980.

| Effective parameter | | | | | | | | Electrical characteristics | | |
|--|--|--|---|---|--|---|-------------------|---------------------------------------|-----------------|-------------------------------------|
| Core factor C ₁ (mm ⁻¹) | Effective magnetic path length ℓ _e (mm) | Effective cross-sectional area A _e (mm ²) | Effective core volume V _e (mm ³) | Cross-sectional center pole area A _{cp} (mm ²) | Minimum cross-sectional center pole area A _{cp min.} (mm ²) | Cross-sectional winding area of core A _{cw} (mm ²) | Weight (g/set) | AL-value * | | Core loss |
| 0.450 | 44.0 | 98.0 | 4310 | 89.9 | 86.6 | 69.5 | 23 | (nH/N ²) 1kHz 0.5mA | 100kHz 200mT | (W)max. 100kHz 200mT 100°C |
| | | | | | | | | 4850±25% | 7000 min. | 1.70 |

* Coil : ø0.4 2UEW 100Ts

○ Calculated output power (forward converter mode): 177.8W (100kHz)

NI limit vs. AL-value (Typ.)

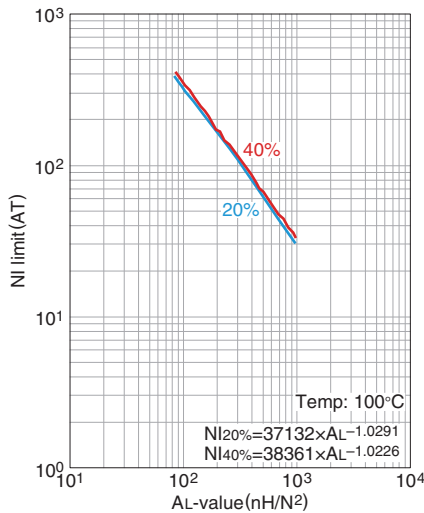

The 20% and 40% graph shows when a 20% and 40% drop from the initial AL-value has been made due to the DC superimposition.

AL-value vs. Air gap length (Typ.)

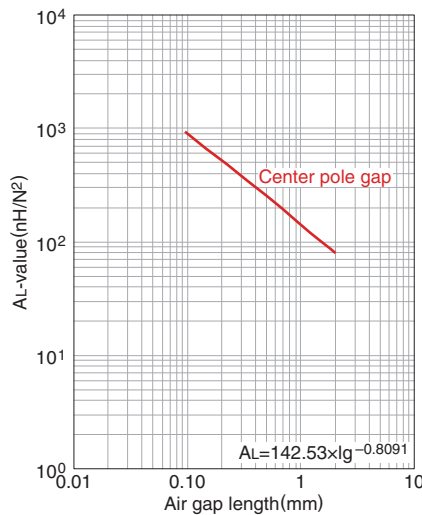

Measuring conditions

- Coil : ø0.4 2UEW 100Ts
- Frequency : 1kHz
- Current level : 0.5mA
- Ambient temperature : 25°C

Temperature rise vs. Total loss (Typ.)

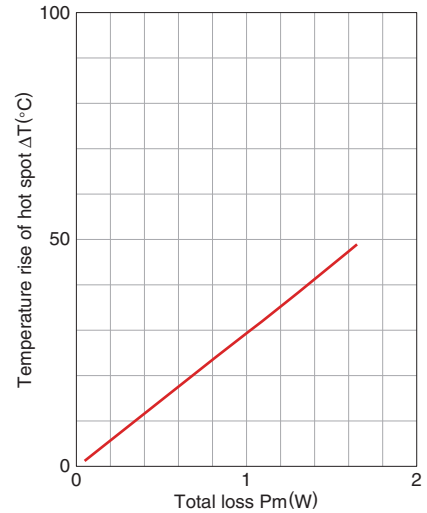

Measuring conditions

- Room space: approx. 400x300x 300cm
- Ambient temperature : 25°C
- Humidity: 45%(%)RH.

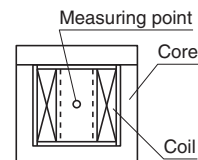

⚠ Please be sure to request delivery specifications that provide further details on the features and specifications of the products for proper and safe use. Please note that the contents may change without any prior notice due to reasons such as upgrading.

Mn-Zn RM series Part No.: PC47RM12Z-12

SHAPES AND DIMENSIONS

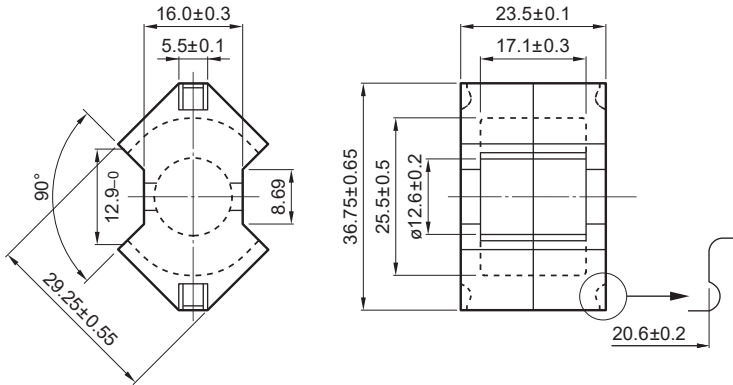

Dimensions in mm

Based on JIS C 2516, IEC Publication 60431.

| Effective parameter | | | | | | | | Electrical characteristics | | |
|--|--|--|---|---|--|---|-------------------|---------------------------------------|-----------------|-------------------------------------|
| Core factor C ₁ (mm ⁻¹) | Effective magnetic path length ℓ _e (mm) | Effective cross-sectional area A _e (mm ²) | Effective core volume V _e (mm ³) | Cross-sectional center pole area A _{cp} (mm ²) | Minimum cross-sectional center pole area A _{cp min.} (mm ²) | Cross-sectional winding area of core A _{cw} (mm ²) | Weight (g/set) | AL-value * | | Core loss |
| 0.406 | 56.9 | 140 | 7960 | 125 | 121 | 110 | 42 | (nH/N ²) 1kHz 0.5mA | 100kHz 200mT | (W)max. 100kHz 200mT 100°C |
| | | | | | | | | 4150 min. | 9290 min. | 3.00 |

* Coil : ø0.4 2UEW 100Ts

○ Calculated output power (forward converter mode): 466.2W (100kHz)

NI limit vs. AL-value (Typ.)

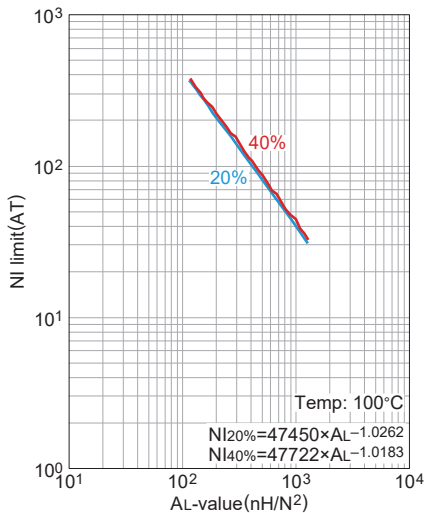

The 20% and 40% graph shows when a 20% and 40% drop from the initial AL-value has been made due to the DC superimposition.

AL-value vs. Air gap length (Typ.)

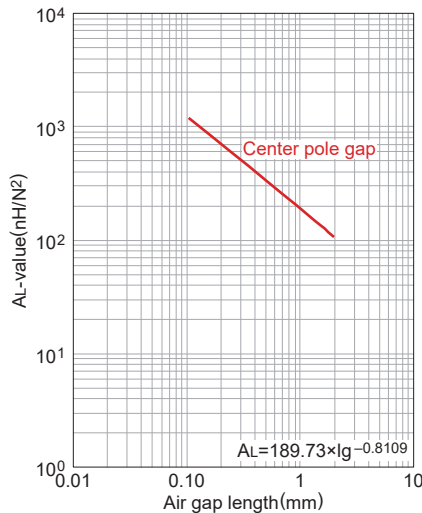

Measuring conditions

- Coil : ø0.4 2UEW 100Ts
- Frequency : 1kHz
- Current level : 0.5mA
- Ambient temperature : 25°C

Temperature rise vs. Total loss (Typ.)

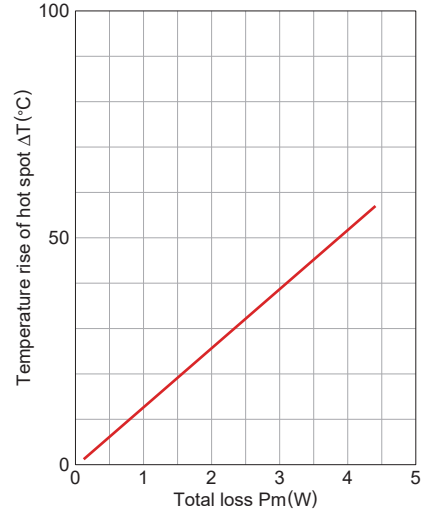

Measuring conditions

- Room space: approx. 400x300x 300cm
- Ambient temperature : 25°C
- Humidity: 45%(%)RH.

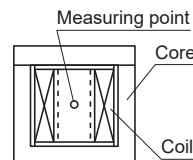

⚠ Please be sure to request delivery specifications that provide further details on the features and specifications of the products for proper and safe use. Please note that the contents may change without any prior notice due to reasons such as upgrading.

Mn-Zn RM series Part No.: PC47RM14Z-12

SHAPES AND DIMENSIONS

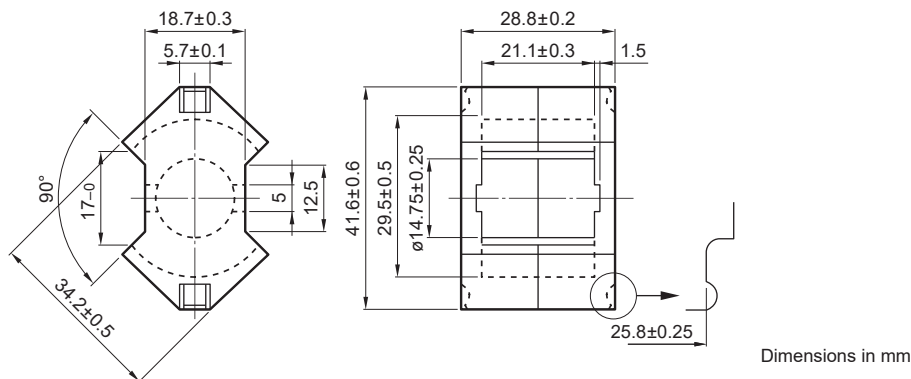

Based on JIS C 2516, IEC Publication 60431 and DIN 41980.

| Effective parameter | | | | | | | | Electrical characteristics | | |
|------------------------|---|---|--|--|---|--|----------------|----------------------------|-----------------|--------------------------|
| Core factor | Effective magnetic path length l_e (mm) | Effective cross-sectional area A_e (mm ²) | Effective core volume V_e (mm ³) | Cross-sectional center pole area A_{cp} (mm ²) | Minimum cross-sectional center pole area $A_{cp \text{ min.}}$ (mm ²) | Cross-sectional winding area of core A_{cw} (mm ²) | Weight (g/set) | AL-value * | | Core loss |
| C1 (mm ⁻¹) | | | | | | | | (nH/N ²) | | (W)max. |
| | | | | | | | | 1kHz 0.5mA | 100kHz 200mT | 100kHz 200mT 100°C |
| 0.393 | 70.0 | 178 | 12500 | 171 | 165 | 155 | 70 | 4600 min. | 9590 min. | 4.60 |

* Coil : $\phi 0.4$ 2UEW 100Ts

○ Calculated output power (forward converter mode): 462.6W (100kHz)

NI limit vs. AL-value (Typ.)

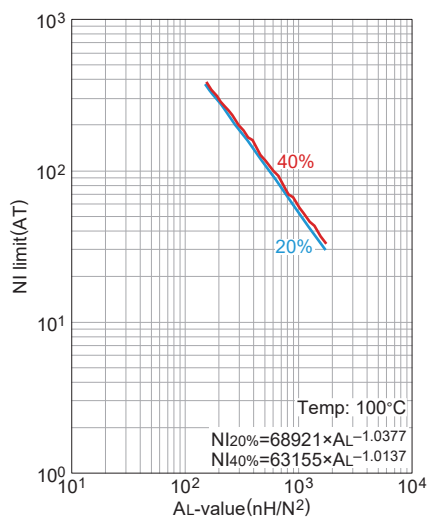

The 20% and 40% graph shows when a 20% and 40% drop from the initial AL-value has been made due to the DC superimposition.

AL-value vs. Air gap length (Typ.)

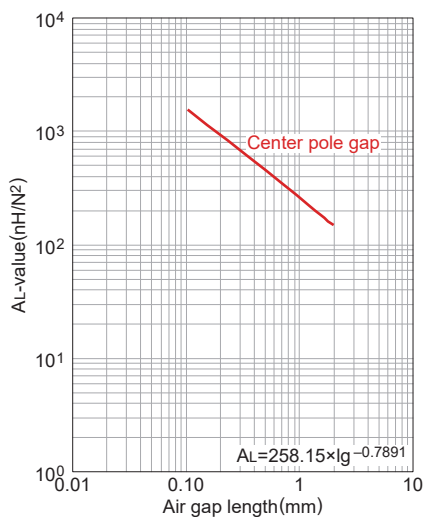

Measuring conditions
 • Coil : $\phi 0.4$ 2UEW 100Ts
 • Frequency : 1kHz
 • Current level : 0.5mA
 • Ambient temperature : 25°C

Temperature rise vs. Total loss (Typ.)

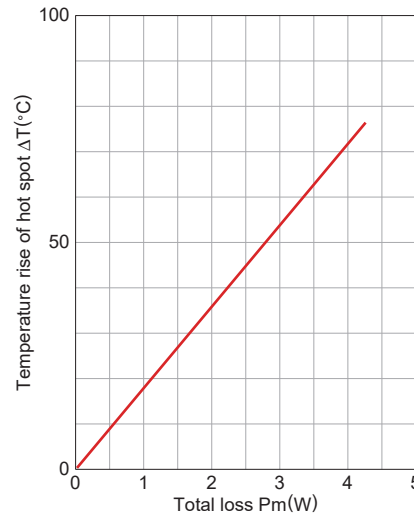

Measuring conditions
 • Room space: approx. 400x300x 300cm
 • Ambient temperature : 25°C
 • Humidity: 45%(%)RH.

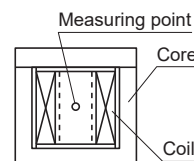

⚠ Please be sure to request delivery specifications that provide further details on the features and specifications of the products for proper and safe use. Please note that the contents may change without any prior notice due to reasons such as upgrading.

Mn-Zn

Ferrite Cores for Switching Power Supplies

SMD series

EE
ER
EEM

 **REMINDERS FOR USING THESE PRODUCTS**

Please be sure to read this manual thoroughly before using the products.

The products listed on this catalog are intended for use in general electronic equipment (AV equipment, telecommunications equipment, home appliances, amusement equipment, computer equipment, personal equipment, office equipment, measurement equipment, industrial robots) under a normal operation and use condition.

The products are not designed or warranted to meet the requirements of the applications listed below, whose performance and/or quality require a more stringent level of safety or reliability, or whose failure, malfunction or trouble could cause serious damage to society, person or property.

When using the products for specific purposes, please first make confirmations in areas such as safety, reliability, and quality.

Please understand that we are not in a position to be held responsible for any damage or the like caused by any use exceeding the range or conditions of this specification sheet or by any use in the specific applications.

- | | |
|---|--|
| (1) Aerospace/Aviation equipment | (8) Public information-processing equipment |
| (2) Transportation equipment (electric trains, ships, etc.) | (9) Military equipment |
| (3) Medical equipment | (10) Electric heating apparatus, burning equipment |
| (4) Power-generation control equipment | (11) Disaster prevention/crime prevention equipment |
| (5) Atomic energy-related equipment | (12) Safety equipment |
| (6) Seabed equipment | (13) Other applications that are not considered general-purpose applications |
| (7) Transportation control equipment | |

When using this product in general-purpose standard applications, you are kindly requested to take into consideration securing protection circuit/equipment or providing backup circuits, etc to ensure higher safety.

Ferrite Cores for Switching Power Supplies

Product compatible with RoHS directive
Halogen-free

Overview of the SMD Series

FEATURES

- Small shapes for surface mounting.
- The EE and EEM Cores are horizontal mounted types.
- The ER Cores are a vertical mounted type.

APPLICATION

Low profile power supplies, Transformers and Coils for DC/DC Converters

PART NUMBER CONSTRUCTION

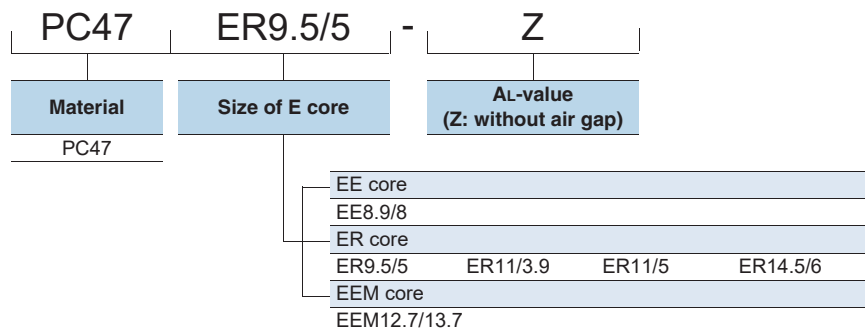

RANGE OF USE AND STORAGE TEMPERATURE

| Temperature range | |
|----------------------------|--------------------------|
| Operating temperature (°C) | Storage temperature (°C) |
| -30 to +105 | -30 to +85 |

- RoHS Directive Compliant Product: See the following for more details related to RoHS Directive compliant products. <http://www.tdk.co.jp/rohs/>
- Halogen-free: Indicates that Cl content is less than 900ppm, Br content is less than 900ppm, and that the total Cl and Br content is less than 1500ppm.

• All specifications are subject to change without notice.

Mn-Zn EE, ER, EEM Cores



SHAPES AND DIMENSIONS

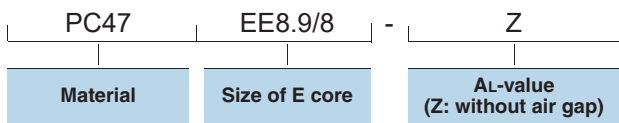
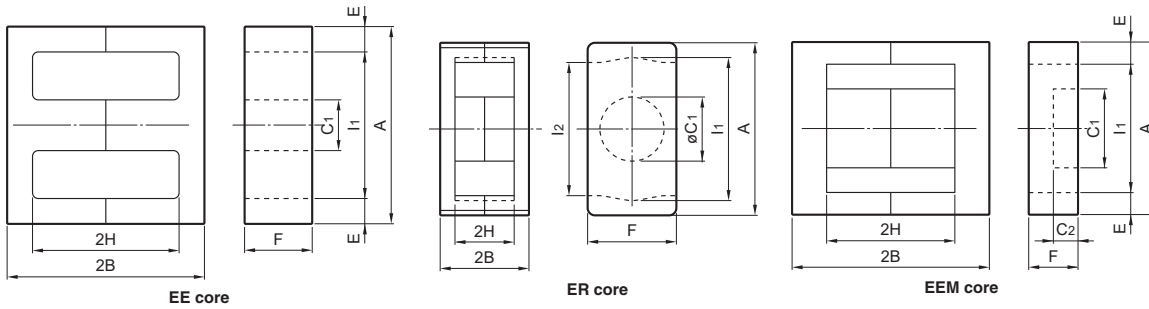

| Part No. | Core | Dimensions (mm) | | | | | | | | |
|--------------------|------|-----------------|-----------|-----------|-----------|-----------|-----------|-----------|-----------|----------|
| | | A | 2B | C1 | C2 | E | F | 2H | l1 | l2 |
| PC47EE8.9/8-Z | EE | 8.86±0.20 | 8.0±0.3 | 1.90±0.12 | | 1.91±0.20 | 1.90±0.12 | 4.5±0.3 | 5.08 min. | |
| PC47ER9.5/5-Z | ER | 9.35±0.15 | 4.9±0.1 | 3.4±0.1 | | | 4.9±0.1 | 3.35±0.15 | 7.63±0.13 | 7.0 min. |
| PC47ER11/3.9-Z | ER | 10.83±0.18 | 3.85±0.10 | 4.13±0.13 | | | 5.9±0.1 | 2.10±0.15 | 8.85±0.15 | 7.9 min. |
| PC47ER11/5-Z | ER | 10.83±0.18 | 4.9±0.1 | 4.13±0.13 | | | 5.9±0.1 | 3.15±0.15 | 8.85±0.15 | 7.9 min. |
| PC47ER14.5/6-Z | ER | 14.5±0.2 | 5.9±0.1 | 4.7±0.1 | | | 6.7±0.1 | 3.3±0.2 | 11.8±0.2 | 11.8±0.2 |
| PC47EEM12.7/13.7-Z | EEM | 12.75±0.25 | 13.7±0.3 | 6.0±0.1 | 1.85±0.10 | 1.7±0.1 | 3.30±0.15 | 9.1±0.3 | 9.0 min. | |

| Part No. | Effective parameter | | | | | Electrical characteristics | |
|--------------------|---|---|---|--|---------------|---|------------------|
| | Core factor C ₁ (mm ⁻¹) | Effective cross-sectional area A _e (mm ²) | Effective magnetic path length ℓ _e (mm) | Effective core volume V _e (mm ³) | Weight (g) | AL-value (nH/N ²) 1kHz 0.5mA 100Ts Without air gap | With air gap |
| PC47EE8.9/8-Z | 3.15 | 4.96 | 15.6 | 77.4 | 0.6 | 480±25% | |
| PC47ER9.5/5-Z | 1.68 | 8.47 | 14.2 | 120 | 0.6 | 610 min. | 63±5% 100±7% |
| PC47ER11/3.9-Z | 1.08 | 11.7 | 12.6 | 147 | 0.8 | 1040 min. | 63±5% 100±7% |
| PC47ER11/5-Z | 1.24 | 11.9 | 14.7 | 175 | 1.0 | 870 min. | 63±5% 100±7% |
| PC47ER14.5/6-Z | 1.08 | 17.6 | 19.0 | 334 | 1.8 | 1280 min. | 100±5% 160±7% |
| PC47EEM12.7/13.7-Z | 2.28 | 12.0 | 27.3 | 328 | 1.9 | 820±25% | 40±5% 63±7% |

• All specifications are subject to change without notice.

Mn-Zn

Ferrite Core for Switching Power Supplies

SP series

**REMINDERS FOR USING THESE PRODUCTS**

Please be sure to read this manual thoroughly before using the products.

The products listed on this catalog are intended for use in general electronic equipment (AV equipment, telecommunications equipment, home appliances, amusement equipment, computer equipment, personal equipment, office equipment, measurement equipment, industrial robots) under a normal operation and use condition.

The products are not designed or warranted to meet the requirements of the applications listed below, whose performance and/or quality require a more stringent level of safety or reliability, or whose failure, malfunction or trouble could cause serious damage to society, person or property.

When using the products for specific purposes, please first make confirmations in areas such as safety, reliability, and quality.

Please understand that we are not in a position to be held responsible for any damage or the like caused by any use exceeding the range or conditions of this specification sheet or by any use in the specific applications.

- | | |
|---|--|
| (1) Aerospace/Aviation equipment | (8) Public information-processing equipment |
| (2) Transportation equipment (electric trains, ships, etc.) | (9) Military equipment |
| (3) Medical equipment | (10) Electric heating apparatus, burning equipment |
| (4) Power-generation control equipment | (11) Disaster prevention/crime prevention equipment |
| (5) Atomic energy-related equipment | (12) Safety equipment |
| (6) Seabed equipment | (13) Other applications that are not considered general-purpose applications |
| (7) Transportation control equipment | |

When using this product in general-purpose standard applications, you are kindly requested to take into consideration securing protection circuit/equipment or providing backup circuits, etc to ensure higher safety.

Ferrite Core for Switching Power Supplies

Product compatible with RoHS directive
Halogen-free

Overview of the Ferrite Core for Switching Power Supplies

FEATURES

- A ferrite core for transformers.
- Can also be used in reactors.

APPLICATION

- Large size industrial equipment, transformers for consumer equipment
- Reactors
- Wireless power transfer

PART NUMBER CONSTRUCTION

| | | | | | | |
|-----------------|-------------------|--------------------|---|--------------------|---|--------------------|
| PC40 | SP | 25 | × | 25 | × | 5 |
| Material | Core shape | Dimension A | | Dimension B | | Dimension C |
| PC40 | SP | 25 | | 25 | | 5 |
| PC95 | | 50 | | 50 | | 5 |
| PEL95 | | 100 | | 100 | | 5 |
| PEM95 | | 70 | | 20 | | 20 |
| | | 110 | | 40 | | 20 |
| | | 135 | | 65 | | 20 |

RANGE OF USE AND STORAGE TEMPERATURE

| Temperature range | |
|----------------------------|--------------------------|
| Operating temperature (°C) | Storage temperature (°C) |
| -30 to +105 | -30 to +85 |

- RoHS Directive Compliant Product: See the following for more details. <https://product.tdk.com/info/en/environment/rohs/index.html>
- Halogen-free: indicates that Cl content is less than 900ppm, Br content is less than 900ppm, and that the total Cl and Br content is less than 1500ppm.

Please be sure to request delivery specifications that provide further details on the features and specifications of the products for proper and safe use. Please note that the contents may change without any prior notice due to reasons such as upgrading.

Mn-Zn SP Cores

SHAPES AND DIMENSIONS

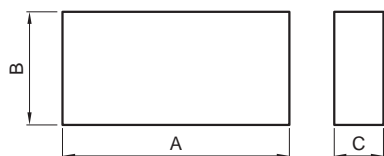

| | | | | | | |
|-----------------|-------------------|--------------------|---|--------------------|---|--------------------|
| PC40 | SP | 25 | x | 25 | x | 5 |
| Material | Core shape | Dimension A | | Dimension B | | Dimension C |

| Material | Part No. | | Dimensions (mm) | | |
|----------|-------------|------------|-----------------|----------|----------|
| | Shape | Dimensions | A | B | C |
| PC40 | SP25x25x5 | 25.0±0.5 | 25.0±0.5 | 25.0±0.5 | 5.0±0.5 |
| PC95 | | | | | |
| PEL95 | | | | | |
| PEM95 | | | | | |
| PC40 | SP50x50x5 | 50.0±1.0 | 50.0±1.0 | 50.0±1.0 | 5.0±0.5 |
| PC95 | | | | | |
| PEL95 | | | | | |
| PEM95 | | | | | |
| PC40 | SP100x100x5 | 100±2.0 | 100±2.0 | 100±2.0 | 5.0±0.5 |
| PC95 | | | | | |
| PEL95 | | | | | |
| PEM95 | | | | | |
| PC40 | SP70X20X20 | 70.0±1.4 | 20.0±0.4 | 20.0±0.4 | 20.0±0.5 |
| PC95 | | | | | |
| PEL95 | | | | | |
| PEM95 | | | | | |
| PC40 | SP110x40x20 | 110.0±2.2 | 40.0±0.8 | 40.0±0.8 | 20.0±0.5 |
| PC95 | | | | | |
| PEL95 | | | | | |
| PEM95 | | | | | |
| PC40 | SP135X65X20 | 135.0±2.5 | 65.0±1.5 | 65.0±1.5 | 20.0±0.5 |
| PC95 | | | | | |
| PEL95 | | | | | |
| PEM95 | | | | | |

⚠ Please be sure to request delivery specifications that provide further details on the features and specifications of the products for proper and safe use. Please note that the contents may change without any prior notice due to reasons such as upgrading.

Mn-Zn

Ferrite Cores for Switching Power Supplies

T series

**REMINDERS FOR USING THESE PRODUCTS**

Please be sure to read this manual thoroughly before using the products.

The products listed on this catalog are intended for use in general electronic equipment (AV equipment, telecommunications equipment, home appliances, amusement equipment, computer equipment, personal equipment, office equipment, measurement equipment, industrial robots) under a normal operation and use condition.

The products are not designed or warranted to meet the requirements of the applications listed below, whose performance and/or quality require a more stringent level of safety or reliability, or whose failure, malfunction or trouble could cause serious damage to society, person or property.

When using the products for specific purposes, please first make confirmations in areas such as safety, reliability, and quality.

Please understand that we are not in a position to be held responsible for any damage or the like caused by any use exceeding the range or conditions of this specification sheet or by any use in the specific applications.

- | | |
|---|--|
| (1) Aerospace/Aviation equipment | (8) Public information-processing equipment |
| (2) Transportation equipment (electric trains, ships, etc.) | (9) Military equipment |
| (3) Medical equipment | (10) Electric heating apparatus, burning equipment |
| (4) Power-generation control equipment | (11) Disaster prevention/crime prevention equipment |
| (5) Atomic energy-related equipment | (12) Safety equipment |
| (6) Seabed equipment | (13) Other applications that are not considered general-purpose applications |
| (7) Transportation control equipment | |

When using this product in general-purpose standard applications, you are kindly requested to take into consideration securing protection circuit/equipment or providing backup circuits, etc to ensure higher safety.

Ferrite Cores for Switching Power Supplies

Product compatible with RoHS directive

Overview of the T Series

FEATURES

- Select from three high permeability magnetic materials of $\mu_i=7000, 10000, 12000$ to match the frequency band used.
- Paraxylene coating is available.

APPLICATION

Common mode choke coils, inductors, current sensors, EMI/RFI filters

PART NUMBER CONSTRUCTION

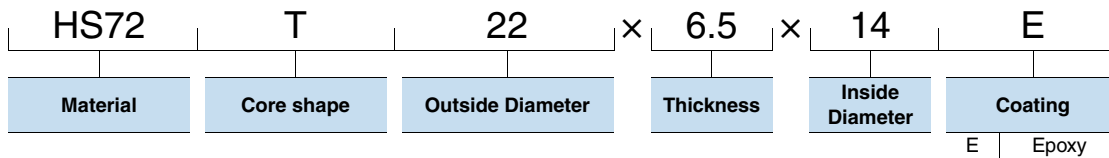

· Can be coated with epoxy. If epoxy-coated products are desired, please suffix E to part No. when ordering.
 Product number example: HS72 T22 × 6.5 × 14E

RANGE OF USE AND STORAGE TEMPERATURE

| Temperature range | |
|----------------------------|--------------------------|
| Operating temperature (°C) | Storage temperature (°C) |
| -30 to +105 | -30 to +85 |

○ RoHS Directive Compliant Product: See the following for more details.<https://product.tdk.com/info/en/environment/rohs/index.html>

⚠ Please be sure to request delivery specifications that provide further details on the features and specifications of the products for proper and safe use. Please note that the contents may change without any prior notice due to reasons such as upgrading.

Mn-Zn T Core



SHAPES AND DIMENSIONS

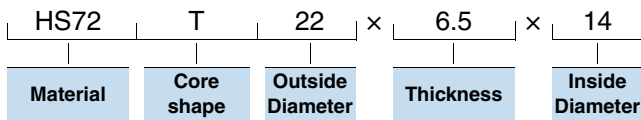
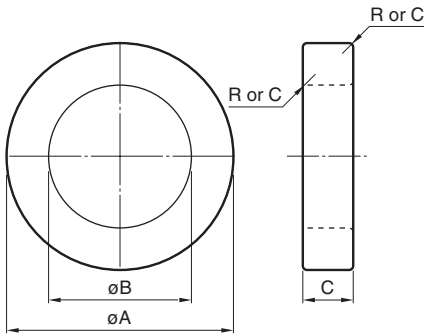

• Can be coated with epoxy. If epoxy-coated products are desired, please suffix E to part No. when ordering.
 Product number example: HS72 T22 × 6.5 × 14E

| Part No. | JIS C 2569 | Dimensions (mm) | | |
|------------------------------------|--------------|-----------------|----------|----------|
| | | øA | øB | C |
| HS72 T14×7×8 HS10 T14×7×8 | | 14.0±0.3 | 8.0±0.3 | 7.0±0.3 |
| HS72 T16×8×12 HS10 T16×8×12 | | 16.0±0.3 | 12.0±0.3 | 8.0±0.3 |
| HS72 T18×10×10 HS10 T18×10×10 | FOR-18-10-10 | 18.0±0.3 | 10.0±0.3 | 10.0±0.3 |
| HS72 T20×10×12 HS10 T20×10×12 | FOR-20-10-12 | 20.0±0.4 | 12.0±0.4 | 10.0±0.3 |
| HS72 T22×6.5×14 HS10 T22×6.5×14 | | 22.0±0.4 | 14.0±0.4 | 6.5±0.3 |

| Part No. | Effective parameter | | | | | Electrical characteristics | | | | |
|------------------------------------|--|--|--|---|--------|----------------------------|----------------------------------|-----------------|--------------|-------------|
| | Core factor C ₁ (mm ⁻¹) | Effective cross-sectional area A _e (mm ²) | Effective magnetic path length ℓ _e (mm) | Effective core volume V _e (mm ³) | R or C | Weigh (g) | AL-value (nH/N ²) | | | |
| | | | | | | | Measuring conditions | | | |
| HS72 T14×7×8 HS10 T14×7×8 | 1.60 | 20.5 | 32.8 | 671 | C0.5 | 3.4 | 5100±25% 6800±30% | 100kHz 10kHz | 10mV 10mV | 5Ts 10Ts |
| HS72 T16×8×12 HS10 T16×8×12 | 2.73 | 15.9 | 43.4 | 689 | C0.3 | 3.4 | 3400±25% 4500±30% | 100kHz 10kHz | 10mV 10mV | 5Ts 10Ts |
| HS72 T18×10×10 HS10 T18×10×10 | 1.07 | 38.9 | 41.5 | 1610 | C0.5 | 8.3 | 8800±25% 10150±30% | 100kHz 10kHz | 10mV 10mV | 5Ts 10Ts |
| HS72 T20×10×12 HS10 T20×10×12 | 1.23 | 39.1 | 48.1 | 1880 | C0.5 | 9.5 | 7600±25% 10000±30% | 100kHz 10kHz | 10mV 10mV | 5Ts 10Ts |
| HS72 T22×6.5×14 HS10 T22×6.5×14 | 2.14 | 25.6 | 54.7 | 1400 | C0.5 | 6.9 | 4400±25% 5750±30% | 100kHz 10kHz | 10mV 10mV | 5Ts 10Ts |

⚠ Please be sure to request delivery specifications that provide further details on the features and specifications of the products for proper and safe use.
 Please note that the contents may change without any prior notice due to reasons such as upgrading.

Mn-Zn T Core



SHAPES AND DIMENSIONS

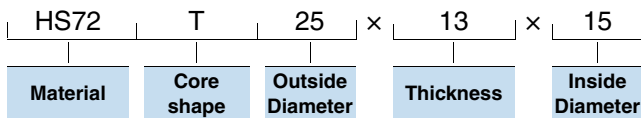
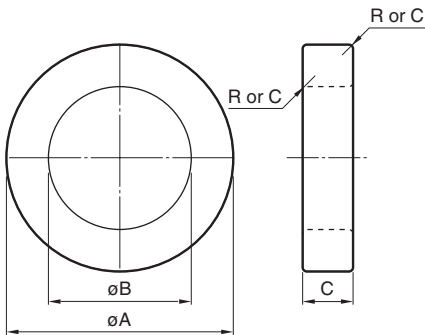

· Can be coated with epoxy. If epoxy-coated products are desired, please suffix E to part No. when ordering.
Product number example: HS72 T22 × 6.5 × 14E

| Part No. | JIS C 2569 | Dimensions (mm) | | |
|----------------------------------|--------------|-----------------|----------|----------|
| | | øA | øB | C |
| HS72 T25×13×15 HS10 T25×13×15 | | 25.0±0.4 | 15.0±0.4 | 13.0±0.3 |
| HS72 T28×13×16 HS10 T28×13×16 | FOR-28-13-16 | 28.0±0.4 | 16.0±0.4 | 13.0±0.3 |
| HS72 T31×8×19 HS10 T31×8×19 | | 31.0±0.5 | 19.0±0.5 | 8.0±0.3 |
| HS72 T38×14×22 | | 38.0±0.5 | 22.0±0.5 | 14.0±0.4 |
| HS72 T44.5×13×30 | FOR-45-13-30 | 44.5±0.5 | 30.0±0.5 | 13.0±0.4 |

| Part No. | Effective parameter | | | | | R or C | Weigh (g) | Electrical characteristics | | |
|----------------------------------|--|--|--|---|----------------------------------|--------|------------------------|----------------------------|--------------|-------------|
| | Core factor C ₁ (mm ⁻¹) | Effective cross-sectional area A _e (mm ²) | Effective magnetic path length ℓ _e (mm) | Effective core volume V _e (mm ³) | AL-value (nH/N ²) | | | Measuring conditions | | |
| HS72 T25×13×15 HS10 T25×13×15 | 0.946 | 63.6 | 60.2 | 3830 | C1.0 | 19 | 9900±25% 13000±30% | 100kHz 10kHz | 10mV 10mV | 5Ts 10Ts |
| HS72 T28×13×16 HS10 T28×13×16 | 0.864 | 76.0 | 65.6 | 4990 | C0.5 | 26 | 10700±25% 14200±30% | 100kHz 10kHz | 10mV 10mV | 5Ts 10Ts |
| HS72 T31×8×19 HS10 T31×8×19 | 1.60 | 47.1 | 75.5 | 3550 | C1.0 | 17 | 5800±25% 7700±30% | 100kHz 10kHz | 10mV 10mV | 5Ts 10Ts |
| HS72 T38×14×22 | 0.821 | 109 | 89.7 | 9800 | C1.0 | 50 | 10700±25% | 100kHz | 10mV | 5Ts |
| HS72 T44.5×13×30 | 1.23 | 93 | 114 | 10600 | C0.5 | 53 | 7100±25% | 100kHz | 10mV | 5Ts |

⚠ Please be sure to request delivery specifications that provide further details on the features and specifications of the products for proper and safe use.
Please note that the contents may change without any prior notice due to reasons such as upgrading.

Mn-Zn

Ferrite Cores for Telecommunication

EP series

 **REMINDERS FOR USING THESE PRODUCTS**

Please be sure to read this manual thoroughly before using the products.

The products listed on this catalog are intended for use in general electronic equipment (AV equipment, telecommunications equipment, home appliances, amusement equipment, computer equipment, personal equipment, office equipment, measurement equipment, industrial robots) under a normal operation and use condition.

The products are not designed or warranted to meet the requirements of the applications listed below, whose performance and/or quality require a more stringent level of safety or reliability, or whose failure, malfunction or trouble could cause serious damage to society, person or property.

When using the products for specific purposes, please first make confirmations in areas such as safety, reliability, and quality.

Please understand that we are not in a position to be held responsible for any damage or the like caused by any use exceeding the range or conditions of this specification sheet or by any use in the specific applications.

- | | |
|---|--|
| (1) Aerospace/Aviation equipment | (8) Public information-processing equipment |
| (2) Transportation equipment (electric trains, ships, etc.) | (9) Military equipment |
| (3) Medical equipment | (10) Electric heating apparatus, burning equipment |
| (4) Power-generation control equipment | (11) Disaster prevention/crime prevention equipment |
| (5) Atomic energy-related equipment | (12) Safety equipment |
| (6) Seabed equipment | (13) Other applications that are not considered general-purpose applications |
| (7) Transportation control equipment | |

When using this product in general-purpose standard applications, you are kindly requested to take into consideration securing protection circuit/equipment or providing backup circuits, etc to ensure higher safety.

Ferrite Cores for Telecommunication

Product compatible with RoHS directive
Halogen-free

Overview of the EP Series

FEATURES

In the EP Cores, there is a single cubic space where a transformer should be mounted, enabling an optimum dimensional ratio to be calculated. Apart from the attaching terminal side, the cores entirely cover the coils.

Further, the coil cross-sections are made round, to improved the low-frequency characteristics of the core, and increase the effective volume.

APPLICATION

Transformers and coils for communication devices

PART NUMBER CONSTRUCTION

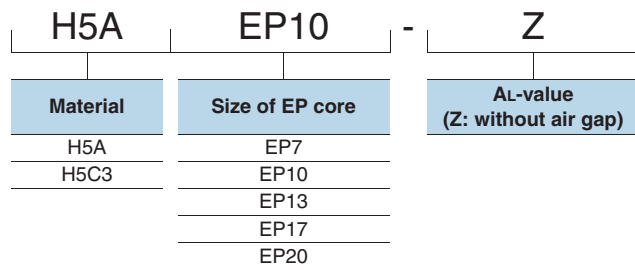

RANGE OF USE AND STORAGE TEMPERATURE

| Temperature range | |
|-------------------------------|-----------------------------|
| Operating temperature (°C) | Storage temperature (°C) |
| -30 to +105 | -30 to +85 |

○ RoHS Directive Compliant Product: See the following for more details related to RoHS Directive compliant products. <http://www.tdk.co.jp/rohs/>

○ Halogen-free: Indicates that Cl content is less than 900ppm, Br content is less than 900ppm, and that the total Cl and Br content is less than 1500ppm.

• All specifications are subject to change without notice.

Mn-Zn EP series **Part No.: H5AEP7-Z**

■ SHAPES AND DIMENSIONS

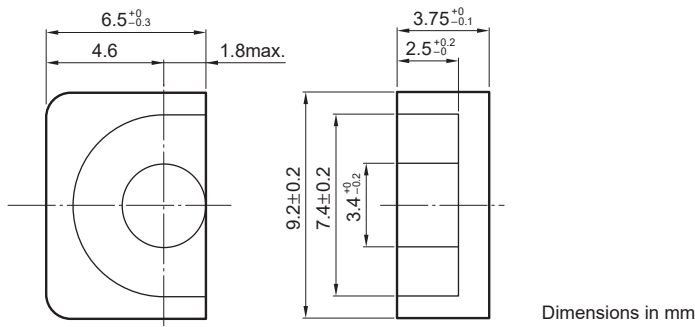

| Effective parameter | | | | | | | Electrical characteristics | | |
|---------------------------------------|--------------------------------|--------------------------------------|--------------------------------------|---------------------------------------|--|---------------------------------------|----------------------------|--------------------------|------------------------|
| Core factor | Effective magnetic path length | Effective cross-sectional area | Effective core volume | Cross-sectional center pole area | Minimum cross-sectional area | Cross-sectional winding area of core | Weight | AL-value | Effective permeability |
| C ₁ (mm ⁻¹) | ℓ _e (mm) | A _e (mm ²) | V _e (mm ³) | A _{cp} (mm ²) | A _{cp min.} (mm ²) | A _{cw} (mm ²) | (g/set) | (nH/N ²)min. | (μe) |
| 1.52 | 15.7 | 10.3 | 162 | 8.55 | 8.04 | 10.7 | 1.4 | 1100 | 1331 |

Measuring conditions
 Coil : ø0.13mm, 2UEW, 100Ts
 Frequency : 1kHz
 Current level : 0.5mA

• All specifications are subject to change without notice.

Mn-Zn EP series **Part No.: H5C3EP7-Z**

■ SHAPES AND DIMENSIONS

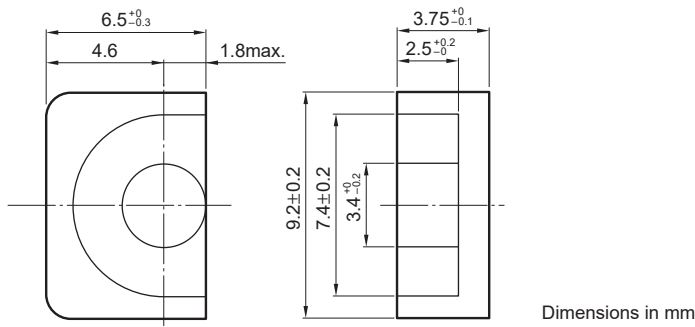

| Effective parameter | | | | | | | | Electrical characteristics | |
|---------------------|--------------------------------|--------------------------------|-----------------------|----------------------------------|------------------------------|--------------------------------------|---------|----------------------------|------------------------|
| Core factor | Effective magnetic path length | Effective cross-sectional area | Effective core volume | Cross-sectional center pole area | Minimum cross-sectional area | Cross-sectional winding area of core | Weigh | AL-value | Effective permeability |
| C_1 | ℓ_e | A_e | V_e | A_{cp} | $A_{cp \text{ min.}}$ | A_{cw} | (g/set) | (nH/N ²)min. | (μe) |
| (mm ⁻¹) | (mm) | (mm ²) | (mm ³) | (mm ²) | (mm ²) | (mm ²) | | | |
| 1.52 | 15.7 | 10.3 | 162 | 8.55 | 8.04 | 10.7 | 1.4 | 4200* | 5080* |

Measuring conditions
 Coil : $\phi 0.13$ mm, 2UEW, 100Ts
 Frequency : 10kHz
 Current level : 0.5mA
 Voltage: 10mV

* All specifications are subject to change without notice.

Mn-Zn EP series **Part No.: H5AEP10-Z**

■ SHAPES AND DIMENSIONS

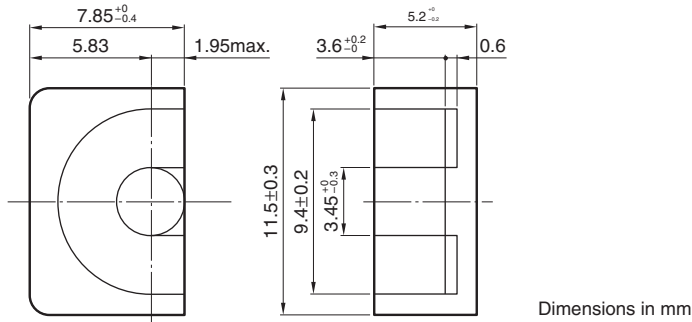

| Effective parameter | | | | | | | | Electrical characteristics | |
|---------------------|--------------------------------|--------------------------------|-----------------------|----------------------------------|------------------------------|--------------------------------------|---------|----------------------------|------------------------|
| Core factor | Effective magnetic path length | Effective cross-sectional area | Effective core volume | Cross-sectional center pole area | Minimum cross-sectional area | Cross-sectional winding area of core | Weigh | AL-value | Effective permeability |
| C_1 | ℓ_e | A_e | V_e | A_{cp} | $A_{cp \text{ min.}}$ | A_{cw} | (g/set) | (nH/N ²)min. | (μ_e) |
| (mm ⁻¹) | (mm) | (mm ²) | (mm ³) | (mm ²) | (mm ²) | (mm ²) | | | |
| 1.7 | 19.2 | 11.3 | 217 | 8.55 | 7.79 | 22.6 | 2.8 | 1080 | 1461 |

Measuring conditions
 Coil : ϕ 0.20mm, 2UEW, 100Ts
 Frequency : 1kHz
 Current level : 0.5mA

• All specifications are subject to change without notice.

Mn-Zn EP series **Part No.: H5C3EP10-Z**

■ SHAPES AND DIMENSIONS

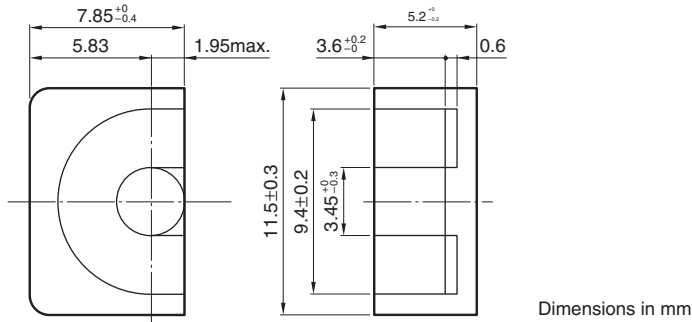

| Effective parameter | | | | | | | | Electrical characteristics | |
|---------------------|--------------------------------|--------------------------------|-----------------------|----------------------------------|------------------------------|--------------------------------------|---------|----------------------------|------------------------|
| Core factor | Effective magnetic path length | Effective cross-sectional area | Effective core volume | Cross-sectional center pole area | Minimum cross-sectional area | Cross-sectional winding area of core | Weigh | AL-value | Effective permeability |
| C_1 | ℓ_e | A_e | V_e | A_{cp} | $A_{cp \text{ min.}}$ | A_{cw} | (g/set) | (nH/N ²)min. | (μ_e) |
| (mm ⁻¹) | (mm) | (mm ²) | (mm ³) | (mm ²) | (mm ²) | (mm ²) | | | |
| 1.7 | 19.2 | 11.3 | 217 | 8.55 | 7.79 | 22.6 | 2.8 | 3850* | 5208* |

Measuring conditions

Coil : $\phi 0.20$ mm, 2UEW, 100Ts

Frequency : 10kHz

Current level : 0.5mA

Voltage: 10mV

• All specifications are subject to change without notice.

Mn-Zn EP series **Part No.: H5AEP13-Z**

■ SHAPES AND DIMENSIONS

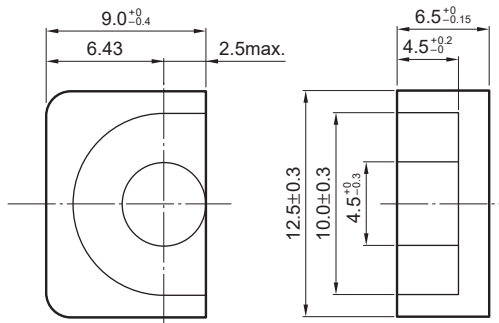

Dimensions in mm

| Effective parameter | | | | | | | | Electrical characteristics | |
|---------------------|--------------------------------|--------------------------------|-----------------------|----------------------------------|------------------------------|--------------------------------------|---------|----------------------------|------------------------|
| Core factor | Effective magnetic path length | Effective cross-sectional area | Effective core volume | Cross-sectional center pole area | Minimum cross-sectional area | Cross-sectional winding area of core | Weigh | AL-value | Effective permeability |
| C_1 | ℓ_e | A_e | V_e | A_{cp} | $A_{cp \text{ min.}}$ | A_{cw} | (g/set) | (nH/N ²)min. | (μ e) |
| (mm ⁻¹) | (mm) | (mm ²) | (mm ³) | (mm ²) | (mm ²) | (mm ²) | | | |
| 1.24 | 24.2 | 19.5 | 472 | 14.9 | 13.9 | 26 | 5.1 | 1700 | 1677 |

Measuring conditions

Coil : ϕ 0.20mm, 2UEW, 100Ts

Frequency : 1kHz

Current level : 0.5mA

Mn-Zn EP series **Part No.: H5C3EP13-Z**

■ SHAPES AND DIMENSIONS

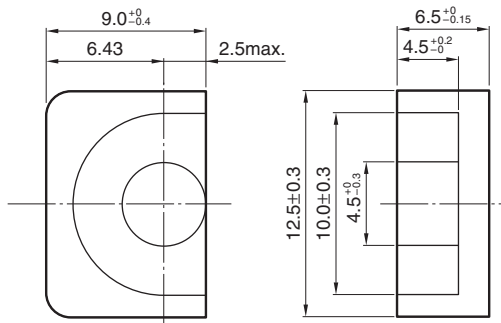

Dimensions in mm

| Effective parameter | | | | | | | | Electrical characteristics | |
|---------------------|--------------------------------|--------------------------------|-----------------------|----------------------------------|------------------------------|--------------------------------------|---------|----------------------------|------------------------|
| Core factor | Effective magnetic path length | Effective cross-sectional area | Effective core volume | Cross-sectional center pole area | Minimum cross-sectional area | Cross-sectional winding area of core | Weigh | AL-value | Effective permeability |
| C_1 | ℓ_e | A_e | V_e | A_{cp} | $A_{cp \text{ min.}}$ | A_{cw} | (g/set) | (nH/N ²)min. | (μe) |
| (mm ⁻¹) | (mm) | (mm ²) | (mm ³) | (mm ²) | (mm ²) | (mm ²) | | | |
| 1.24 | 24.2 | 19.5 | 472 | 14.9 | 13.9 | 26 | 5.1 | 5600* | 5526* |

Measuring conditions

Coil : ϕ 0.20mm, 2UEW, 100Ts

Frequency : 10kHz

Current level : 0.5mA

Voltage: 10mV

• All specifications are subject to change without notice.

Mn-Zn EP series **Part No.: H5AEP17-Z**

■ SHAPES AND DIMENSIONS

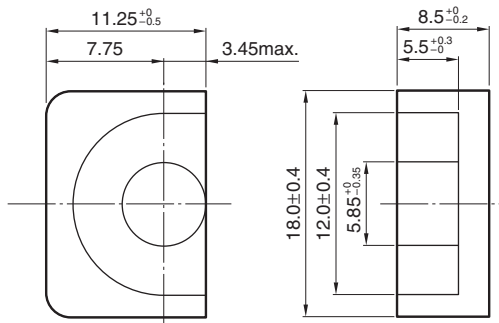

Dimensions in mm

| Effective parameter | | | | | | | | Electrical characteristics | |
|---------------------|--------------------------------|--------------------------------|-----------------------|----------------------------------|------------------------------|--------------------------------------|---------|----------------------------|------------------------|
| Core factor | Effective magnetic path length | Effective cross-sectional area | Effective core volume | Cross-sectional center pole area | Minimum cross-sectional area | Cross-sectional winding area of core | Weigh | AL-value | Effective permeability |
| C_1 | ℓ_e | A_e | V_e | A_{cp} | $A_{cp \text{ min.}}$ | A_{cw} | (g/set) | (nH/N ²)min. | (μ_e) |
| (mm ⁻¹) | (mm) | (mm ²) | (mm ³) | (mm ²) | (mm ²) | (mm ²) | | | |
| 0.84 | 28.5 | 33.9 | 966 | 25.3 | 23.8 | 33.8 | 11.8 | 2500 | 1672 |

Measuring conditions

Coil : ϕ 0.20mm, 2UEW, 100Ts

Frequency : 1kHz

Current level : 0.5mA

Mn-Zn EP series **Part No.: H5C2EP17-Z**

■ SHAPES AND DIMENSIONS

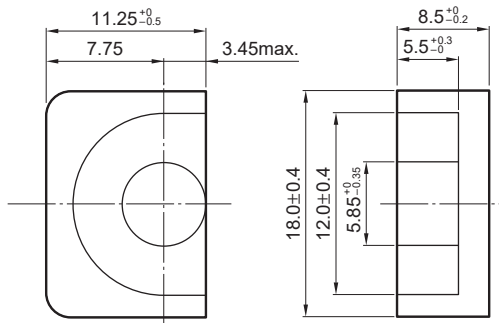

Dimensions in mm

| Effective parameter | | | | | | | | Electrical characteristics | |
|---------------------|--------------------------------|--------------------------------|-----------------------|----------------------------------|------------------------------|--------------------------------------|---------|----------------------------|------------------------|
| Core factor | Effective magnetic path length | Effective cross-sectional area | Effective core volume | Cross-sectional center pole area | Minimum cross-sectional area | Cross-sectional winding area of core | Weigh | AL-value | Effective permeability |
| C_1 | ℓ_e | A_e | V_e | A_{cp} | $A_{cp \text{ min.}}$ | A_{cw} | (g/set) | (nH/N ²)min. | (μ_e) |
| (mm ⁻¹) | (mm) | (mm ²) | (mm ³) | (mm ²) | (mm ²) | (mm ²) | | | |
| 0.84 | 28.5 | 33.9 | 966 | 25.3 | 23.8 | 33.8 | 11.8 | 8000 | 5350 |

Measuring conditions

Coil : ϕ 0.20mm, 2UEW, 100Ts

Frequency : 1kHz

Current level : 0.5mA

Mn-Zn EP series **Part No.: H5AEP20-Z**

■ SHAPES AND DIMENSIONS

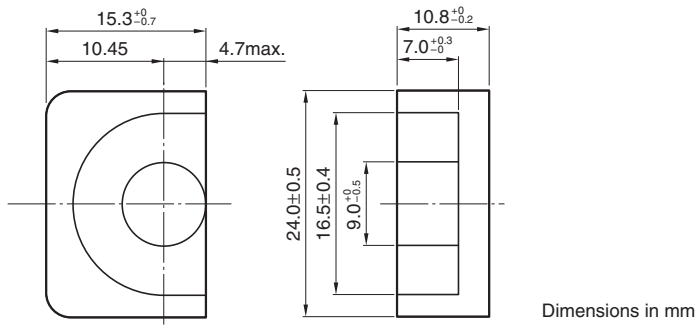

| Effective parameter | | | | | | | | Electrical characteristics | |
|---------------------|--------------------------------|--------------------------------|-----------------------|----------------------------------|------------------------------|--------------------------------------|---------|----------------------------|------------------------|
| Core factor | Effective magnetic path length | Effective cross-sectional area | Effective core volume | Cross-sectional center pole area | Minimum cross-sectional area | Cross-sectional winding area of core | Weight | AL-value | Effective permeability |
| C_1 | ℓ_e | A_e | V_e | A_{cp} | $A_{cp \text{ min.}}$ | A_{cw} | (g/set) | (nH/N ²)min. | (μ e) |
| (mm ⁻¹) | (mm) | (mm ²) | (mm ³) | (mm ²) | (mm ²) | (mm ²) | | | |
| 0.508 | 39.8 | 78 | 312 | 60.1 | 56.7 | 55.4 | 27.6 | 4200 | 1698 |

Measuring conditions
 Coil : ϕ 0.35mm, 2UEW, 100Ts
 Frequency : 1kHz
 Current level : 0.5mA

• All specifications are subject to change without notice.

Mn-Zn EP series **Part No.: H5C2EP20-Z**

■ SHAPES AND DIMENSIONS

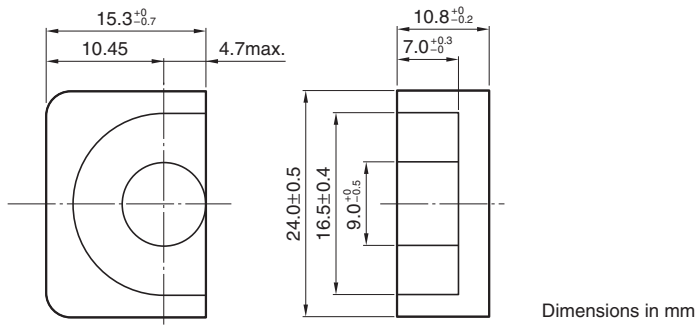

| Effective parameter | | | | | | | | Electrical characteristics | |
|---------------------|--------------------------------|--------------------------------|-----------------------|----------------------------------|------------------------------|--------------------------------------|---------|----------------------------|------------------------|
| Core factor | Effective magnetic path length | Effective cross-sectional area | Effective core volume | Cross-sectional center pole area | Minimum cross-sectional area | Cross-sectional winding area of core | Weigh | AL-value | Effective permeability |
| C_1 | ℓ_e | A_e | V_e | A_{cp} | $A_{cp \text{ min.}}$ | A_{cw} | (g/set) | (nH/N ²)min. | (μ e) |
| (mm ⁻¹) | (mm) | (mm ²) | (mm ³) | (mm ²) | (mm ²) | (mm ²) | | | |
| 0.508 | 39.8 | 78 | 312 | 60.1 | 56.7 | 55.4 | 27.6 | 13500 | 5457 |

Measuring conditions
 Coil : ϕ 0.35mm, 2UEW, 100Ts
 Frequency : 1kHz
 Current level : 0.5mA

• All specifications are subject to change without notice.

Mn-Zn

Ferrite Core for Telecommunication

P series

 **REMINDERS FOR USING THESE PRODUCTS**

Please be sure to read this manual thoroughly before using the products.

The products listed on this catalog are intended for use in general electronic equipment (AV equipment, telecommunications equipment, home appliances, amusement equipment, computer equipment, personal equipment, office equipment, measurement equipment, industrial robots) under a normal operation and use condition.

The products are not designed or warranted to meet the requirements of the applications listed below, whose performance and/or quality require a more stringent level of safety or reliability, or whose failure, malfunction or trouble could cause serious damage to society, person or property.

When using the products for specific purposes, please first make confirmations in areas such as safety, reliability, and quality.

Please understand that we are not in a position to be held responsible for any damage or the like caused by any use exceeding the range or conditions of this specification sheet or by any use in the specific applications.

- | | |
|---|--|
| (1) Aerospace/Aviation equipment | (8) Public information-processing equipment |
| (2) Transportation equipment (electric trains, ships, etc.) | (9) Military equipment |
| (3) Medical equipment | (10) Electric heating apparatus, burning equipment |
| (4) Power-generation control equipment | (11) Disaster prevention/crime prevention equipment |
| (5) Atomic energy-related equipment | (12) Safety equipment |
| (6) Seabed equipment | (13) Other applications that are not considered general-purpose applications |
| (7) Transportation control equipment | |

When using this product in general-purpose standard applications, you are kindly requested to take into consideration securing protection circuit/equipment or providing backup circuits, etc to ensure higher safety.

Ferrite Cores for Telecommunication

Product compatible with RoHS directive
Halogen-free

Overview of the P Series

FEATURES

- The pot cores have a good self-shielding property.
- The shape gives a high inductance value to each occupied space.

APPLICATION

Various transformers, coils, proximity sensors

PART NUMBER CONSTRUCTION

| H5A | P5.8/3.3 | Z | - | 5 | 2 | S |
|----------|----------------|----------------------------------|------------------|---------------------|--------------------|---|
| Material | Size of P core | AL-value (Z: without air gap) | Type of Pot core | Number of lead slot | Shape of lead slot | |
| H5A | P5.8/3.3 | | | | | |
| H5C2 | P7/4 | | | | | |
| | P9/5 | | | | | |
| | P11/7 | | | | | |
| | P14/8 | | | | | |
| | P18/11 | | | | | |
| | P22/13 | | | | | |
| | P26/16 | | | | | |
| | P30/19 | | | | | |

RANGE OF USE AND STORAGE TEMPERATURE

| Temperature range | |
|-------------------------------|-----------------------------|
| Operating temperature (°C) | Storage temperature (°C) |
| -30 to +105 | -30 to +85 |

- RoHS Directive Compliant Product: See the following for more details related to RoHS Directive compliant products. <http://www.tdk.co.jp/rohs/>
- Halogen-free: Indicates that Cl content is less than 900ppm, Br content is less than 900ppm, and that the total Cl and Br content is less than 1500ppm.

• All specifications are subject to change without notice.

Mn-Zn P series **Part No.: H5AP5.8/3.3Z-52S**

■ SHAPES AND DIMENSIONS

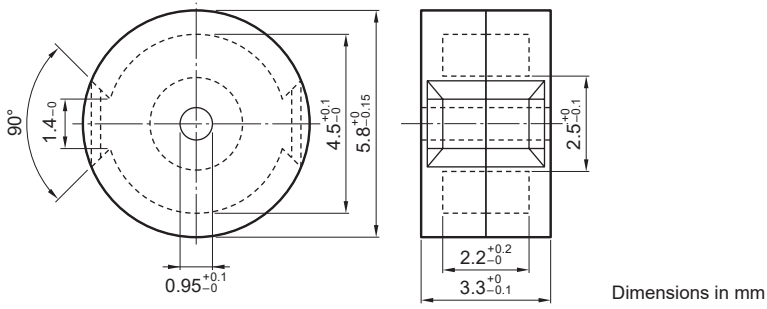

Base on IEC Publication 62317-2.

| Effective parameter | | | | | | | | Electrical characteristics | |
|---------------------|--------------------------------|--------------------------------|-----------------------|----------------------------------|------------------------------|--------------------------------------|---------|----------------------------|------------------------|
| Core factor | Effective magnetic path length | Effective cross-sectional area | Effective core volume | Cross-sectional center pole area | Minimum cross-sectional area | Cross-sectional winding area of core | Weigh | AL-value | Effective permeability |
| C ₁ | ℓ _e | A _e | V _e | A _{cp} | A _{cp min.} | A _{cw} | (g/set) | (nH/N ²) | (μe) |
| (mm ⁻¹) | (mm) | (mm ²) | (mm ³) | (mm ²) | (mm ²) | (mm ²) | | | |
| 1.68 | 7.9 | 4.7 | 37 | 4.08 | 3.66 | 2.42 | 0.2 | 870±25% | 1163 |

Measuring conditions

Coil : ø0.08mm, 2UEW, 100Ts, 70Ts (for material H5C2)

Frequency : 1kHz

Current level : 0.5mA

Mn-Zn P series **Part No.: H5C2P5.8/3.3Z-52S**

■ SHAPES AND DIMENSIONS

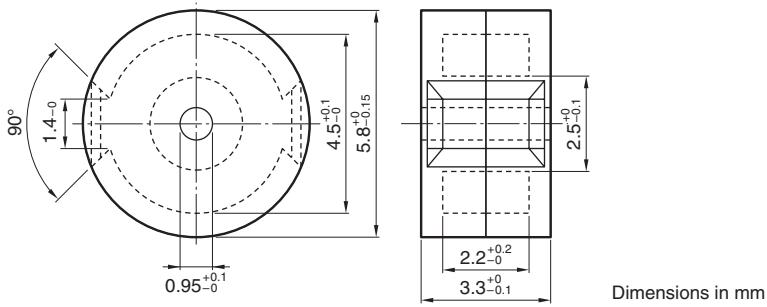

Base on IEC Publication 62317-2.

| Effective parameter | | | | | | | | Electrical characteristics | |
|---------------------|--------------------------------|--------------------------------|-----------------------|----------------------------------|------------------------------|--------------------------------------|---------|----------------------------|------------------------|
| Core factor | Effective magnetic path length | Effective cross-sectional area | Effective core volume | Cross-sectional center pole area | Minimum cross-sectional area | Cross-sectional winding area of core | Weigh | AL-value | Effective permeability |
| C ₁ | ℓ _e | A _e | V _e | A _{cp} | A _{cp min.} | A _{cw} | (g/set) | (nH/N ²) | (μe) |
| (mm ⁻¹) | (mm) | (mm ²) | (mm ³) | (mm ²) | (mm ²) | (mm ²) | | | |
| 1.68 | 7.9 | 4.7 | 37 | 4.08 | 3.66 | 2.42 | 0.2 | 2660 min. | 3556 |

Measuring conditions

Coil : ø0.08mm, 2UEW, 100Ts, 70Ts (for material H5C2)

Frequency : 1kHz

Current level : 0.5mA

Mn-Zn P series Part No.: H5AP7/4Z-52S

SHAPES AND DIMENSIONS

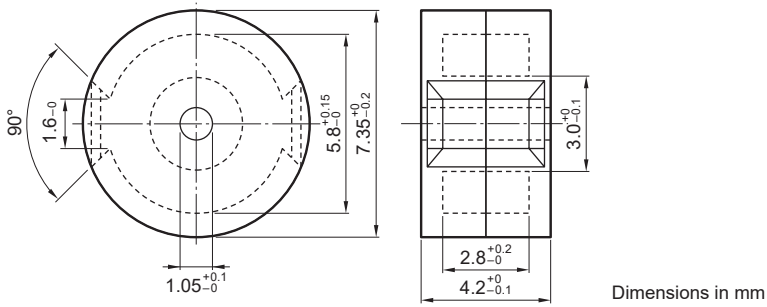

Dimensions in mm

Base on IEC Publication 62317-2.

| Effective parameter | | | | | | | | Electrical characteristics | |
|---------------------|--------------------------------|--------------------------------|-----------------------|----------------------------------|------------------------------|--------------------------------------|---------|----------------------------|------------------------|
| Core factor | Effective magnetic path length | Effective cross-sectional area | Effective core volume | Cross-sectional center pole area | Minimum cross-sectional area | Cross-sectional winding area of core | Weigh | AL-value | Effective permeability |
| C ₁ | ℓ _e | A _e | V _e | A _{cp} | A _{cp min.} | A _{cw} | (g/set) | (nH/N ²) | (μe) |
| (mm ⁻¹) | (mm) | (mm ²) | (mm ³) | (mm ²) | (mm ²) | (mm ²) | | | |
| 1.43 | 10 | 7.0 | 70 | 6.05 | 5.57 | 4.31 | 0.5 | 1200±25% | 1366 |

Measuring conditions

Coil : ø0.1mm, 2UEW, 100Ts

Frequency : 1kHz

Current level : 0.5mA

Mn-Zn P series **Part No.: H5C2P7/4Z-52S**

■ SHAPES AND DIMENSIONS

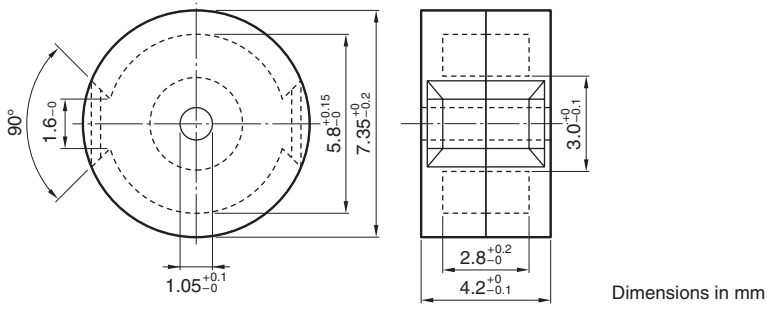

Base on IEC Publication 62317-2.

| Effective parameter | | | | | | | Electrical characteristics | | |
|---------------------|--------------------------------|--------------------------------|-----------------------|----------------------------------|------------------------------|--------------------------------------|----------------------------|----------------------|------------------------|
| Core factor | Effective magnetic path length | Effective cross-sectional area | Effective core volume | Cross-sectional center pole area | Minimum cross-sectional area | Cross-sectional winding area of core | Weigh | AL-value | Effective permeability |
| C ₁ | ℓ _e | A _e | V _e | A _{cp} | A _{cp min.} | A _{cw} | (g/set) | (nH/N ²) | (μe) |
| (mm ⁻¹) | (mm) | (mm ²) | (mm ³) | (mm ²) | (mm ²) | (mm ²) | | | |
| 1.43 | 10 | 7.0 | 70 | 6.05 | 5.57 | 4.31 | 0.5 | 4970±30% | 5656 |

Measuring conditions

Coil : ø0.1mm, 2UEW, 70Ts

Frequency : 1kHz

Current level : 0.5mA

Mn-Zn P series **Part No.: H5AP9/5Z-52H**

■ SHAPES AND DIMENSIONS

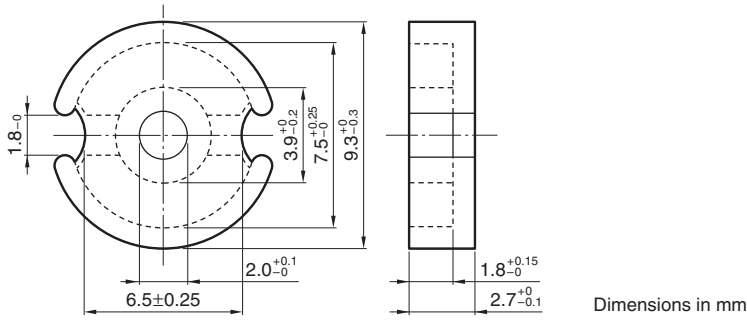

Base on JIS C2516, IEC Publication 62317-2.

| Effective parameter | | | | | | | Electrical characteristics | | |
|---------------------|--------------------------------|--------------------------------|-----------------------|----------------------------------|------------------------------|--------------------------------------|----------------------------|----------------------|------------------------|
| Core factor | Effective magnetic path length | Effective cross-sectional area | Effective core volume | Cross-sectional center pole area | Minimum cross-sectional area | Cross-sectional winding area of core | Weigh | AL-value | Effective permeability |
| C_1 | ℓ_e | A_e | V_e | A_{cp} | $A_{cp \text{ min.}}$ | A_{cw} | (g/set) | (nH/N ²) | (μ_e) |
| (mm ⁻¹) | (mm) | (mm ²) | (mm ³) | (mm ²) | (mm ²) | (mm ²) | | | |
| 1.24 | 12.4 | 10.0 | 124 | 8.04 | 7.29 | 7.17 | 0.8 | 1570±25% | 1562 |

Measuring conditions

Coil : ϕ 0.1mm, 2UEW, 100Ts

Frequency : 1kHz

Current level : 0.5mA

Mn-Zn P series Part No.: H5C2P9/5Z-52H

SHAPES AND DIMENSIONS

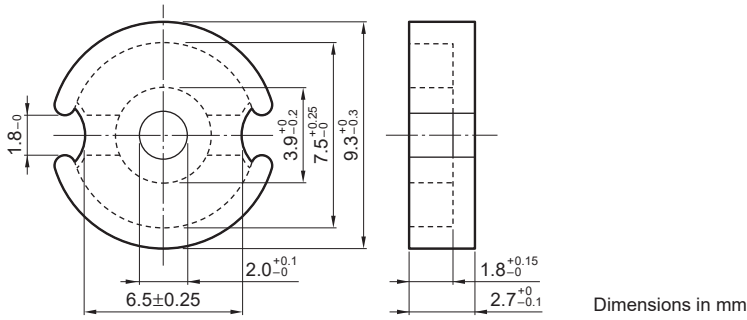

Base on JIS C2516, IEC Publication 62317-2.

| Effective parameter | | | | | | | | Electrical characteristics | |
|---------------------|--------------------------------|--------------------------------|-----------------------|----------------------------------|------------------------------|--------------------------------------|---------|----------------------------|------------------------|
| Core factor | Effective magnetic path length | Effective cross-sectional area | Effective core volume | Cross-sectional center pole area | Minimum cross-sectional area | Cross-sectional winding area of core | Weigh | AL-value | Effective permeability |
| C ₁ | ℓ _e | A _e | V _e | A _{cp} | A _{cp min.} | A _{cw} | (g/set) | (nH/N ²) | (μe) |
| (mm ⁻¹) | (mm) | (mm ²) | (mm ³) | (mm ²) | (mm ²) | (mm ²) | | | |
| 1.24 | 12.4 | 10.0 | 124 | 8.04 | 7.29 | 7.17 | 0.8 | 6030±30% | 5998 |

Measuring conditions

Coil : ø0.1mm, 2UEW, 70Ts

Frequency : 1kHz

Current level : 0.5mA

Mn-Zn P series Part No.: H5AP11/7Z-52H

SHAPES AND DIMENSIONS

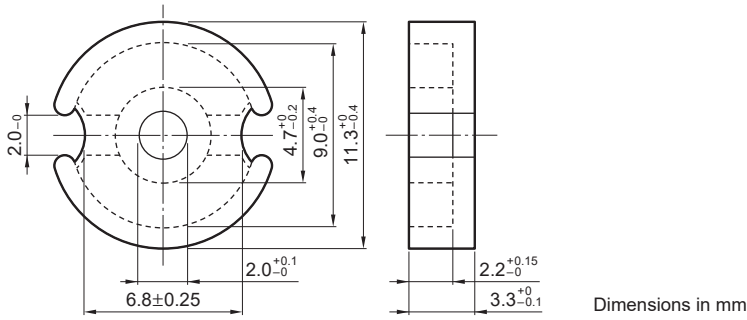

Base on JIS C2516, IEC Publication 62317-2.

| Effective parameter | | | | | | | | Electrical characteristics | |
|---------------------|--------------------------------|--------------------------------|-----------------------|----------------------------------|------------------------------|--------------------------------------|---------|----------------------------|------------------------|
| Core factor | Effective magnetic path length | Effective cross-sectional area | Effective core volume | Cross-sectional center pole area | Minimum cross-sectional area | Cross-sectional winding area of core | Weigh | AL-value | Effective permeability |
| C ₁ | ℓ _e | A _e | V _e | A _{cp} | A _{cp min.} | A _{cw} | (g/set) | (nH/N ²) | (μe) |
| (mm ⁻¹) | (mm) | (mm ²) | (mm ³) | (mm ²) | (mm ²) | (mm ²) | | | |
| 0.969 | 15.5 | 16.0 | 248 | 13.3 | 12.4 | 10.5 | 1.8 | 2320±25% | 1765 |

Measuring conditions

Coil : ø0.18mm, 2UEW, 100Ts,

Frequency : 1kHz

Current level : 0.5mA

Mn-Zn P series **Part No.: H5C2P11/7Z-52H**

■ SHAPES AND DIMENSIONS

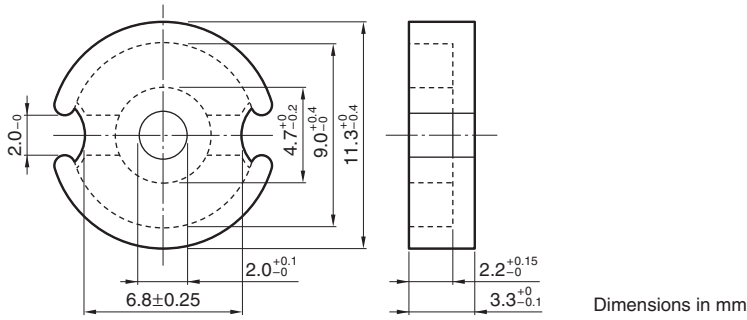

Base on JIS C2516, IEC Publication 62317-2.

| Effective parameter | | | | | | | Electrical characteristics | | |
|---------------------|--------------------------------|--------------------------------|-----------------------|----------------------------------|------------------------------|--------------------------------------|----------------------------|----------------------|------------------------|
| Core factor | Effective magnetic path length | Effective cross-sectional area | Effective core volume | Cross-sectional center pole area | Minimum cross-sectional area | Cross-sectional winding area of core | Weigh | AL-value | Effective permeability |
| C_1 | ℓ_e | A_e | V_e | A_{cp} | $A_{cp \text{ min.}}$ | A_{cw} | (g/set) | (nH/N ²) | (μ_e) |
| (mm ⁻¹) | (mm) | (mm ²) | (mm ³) | (mm ²) | (mm ²) | (mm ²) | | | |
| 0.969 | 15.5 | 16.0 | 248 | 13.3 | 12.4 | 10.5 | 1.8 | 8220±30% | 6253 |

Measuring conditions

Coil : ϕ 0.18mm, 2UEW, 70Ts

Frequency : 1kHz

Current level : 0.5mA

Mn-Zn P series **Part No.: H5AP14/8Z-52B**

■ SHAPES AND DIMENSIONS

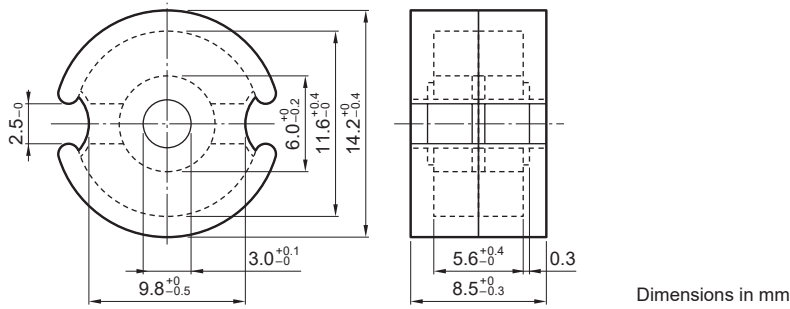

Base on JIS C2516, IEC Publication 62317-2.

| Effective parameter | | | | | | | | Electrical characteristics | |
|---------------------|--------------------------------|--------------------------------|-----------------------|----------------------------------|------------------------------|--------------------------------------|---------|----------------------------|------------------------|
| Core factor | Effective magnetic path length | Effective cross-sectional area | Effective core volume | Cross-sectional center pole area | Minimum cross-sectional area | Cross-sectional winding area of core | Weight | AL-value | Effective permeability |
| C ₁ | ℓ _e | A _e | V _e | A _{cp} | A _{cp min.} | A _{cw} | (g/set) | (nH/N ²) | (μe) |
| (mm ⁻¹) | (mm) | (mm ²) | (mm ³) | (mm ²) | (mm ²) | (mm ²) | | | |
| 0.789 | 19.8 | 25.1 | 497 | 19.8 | 18.4 | 17.1 | 3.2 | 3000±25% | 1884 |

Measuring conditions

Coil : ø0.18mm, 2UEW, 100Ts

Frequency : 1kHz

Current level : 0.5mA

Mn-Zn P series **Part No.: H5C2P14/8Z-52B**

■ SHAPES AND DIMENSIONS

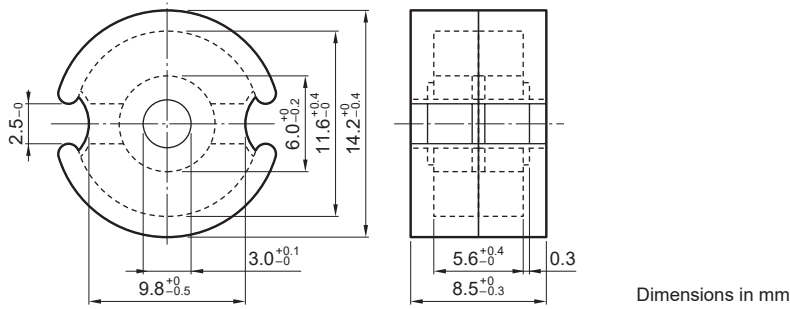

Base on JIS C2516, IEC Publication 62317-2.

| Effective parameter | | | | | | | | Electrical characteristics | |
|---------------------|--------------------------------|--------------------------------|-----------------------|----------------------------------|------------------------------|--------------------------------------|---------|----------------------------|------------------------|
| Core factor | Effective magnetic path length | Effective cross-sectional area | Effective core volume | Cross-sectional center pole area | Minimum cross-sectional area | Cross-sectional winding area of core | Weigh | AL-value | Effective permeability |
| C ₁ | ℓ _e | A _e | V _e | A _{cp} | A _{cp min.} | A _{cw} | (g/set) | (nH/N ²) | (μe) |
| (mm ⁻¹) | (mm) | (mm ²) | (mm ³) | (mm ²) | (mm ²) | (mm ²) | | | |
| 0.789 | 19.8 | 25.1 | 497 | 19.8 | 18.4 | 17.1 | 3.2 | 11500±30% | 7221 |

Measuring conditions

Coil : ø0.18mm, 2UEW, 100Ts

Frequency : 1kHz

Current level : 0.5mA

Mn-Zn P series **Part No.: H5AP18/11Z-52B**

■ SHAPES AND DIMENSIONS

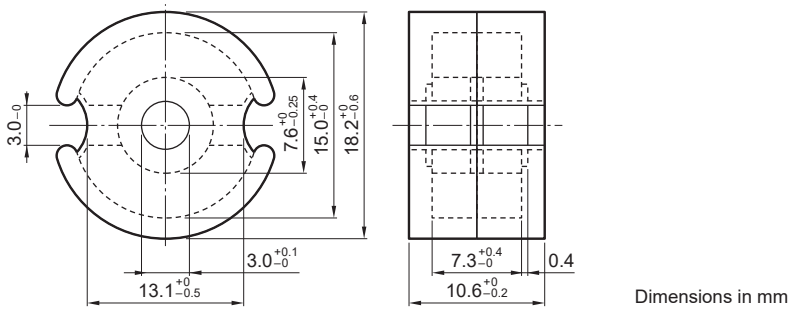

Base on JIS C2516, IEC Publication 62317-2.

| Effective parameter | | | | | | | | Electrical characteristics | |
|---------------------|--------------------------------|--------------------------------|-----------------------|----------------------------------|------------------------------|--------------------------------------|---------|----------------------------|------------------------|
| Core factor | Effective magnetic path length | Effective cross-sectional area | Effective core volume | Cross-sectional center pole area | Minimum cross-sectional area | Cross-sectional winding area of core | Weight | AL-value | Effective permeability |
| C ₁ | ℓ _e | A _e | V _e | A _{cp} | A _{cp min.} | A _{cw} | (g/set) | (nH/N ²) | (μe) |
| (mm ⁻¹) | (mm) | (mm ²) | (mm ³) | (mm ²) | (mm ²) | (mm ²) | | | |
| 0.596 | 25.8 | 43.3 | 1117 | 36.3 | 34.4 | 29 | 6.7 | 4500±25% | 2138 |

Measuring conditions

Coil : ø0.30mm, 2UEW, 100Ts

Frequency : 1kHz

Current level : 0.5mA

Mn-Zn P series **Part No.: H5C2P18/11Z-52B**

■ SHAPES AND DIMENSIONS

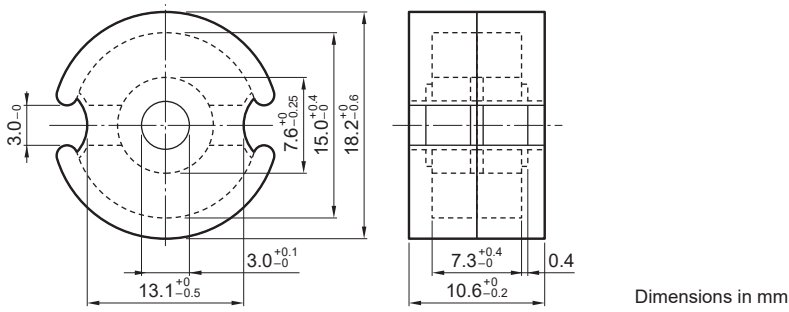

Base on JIS C2516, IEC Publication 62317-2.

| Effective parameter | | | | | | | | Electrical characteristics | |
|---------------------|--------------------------------|--------------------------------|-----------------------|----------------------------------|------------------------------|--------------------------------------|---------|----------------------------|------------------------|
| Core factor | Effective magnetic path length | Effective cross-sectional area | Effective core volume | Cross-sectional center pole area | Minimum cross-sectional area | Cross-sectional winding area of core | Weight | AL-value | Effective permeability |
| C ₁ | ℓ _e | A _e | V _e | A _{cp} | A _{cp min.} | A _{cw} | (g/set) | (nH/N ²) | (μe) |
| (mm ⁻¹) | (mm) | (mm ²) | (mm ³) | (mm ²) | (mm ²) | (mm ²) | | | |
| 0.596 | 25.8 | 43.3 | 1117 | 36.3 | 34.4 | 29 | 6.7 | 4500±25% | 2138 |
| | | | | | | | | 16000±30% | 7601 |

Measuring conditions

Coil : ø0.30mm, 2UEW, 100Ts

Frequency : 1kHz

Current level : 0.5mA

Mn-Zn P series **Part No.: H5AP22/13Z-52H**

■ SHAPES AND DIMENSIONS

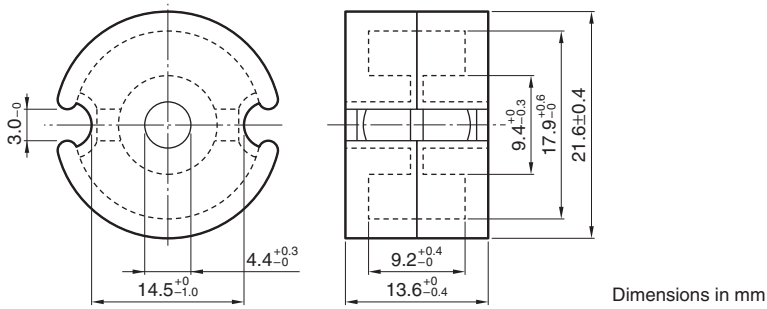

Dimensions in mm

Base on JIS C2516, IEC Publication 62317-2.

| Effective parameter | | | | | | | Electrical characteristics | | | |
|---------------------|--------------------------------|--------------------------------|-----------------------|----------------------------------|------------------------------|--------------------------------------|----------------------------|----------------------|------------------------|--|
| Core factor | Effective magnetic path length | Effective cross-sectional area | Effective core volume | Cross-sectional center pole area | Minimum cross-sectional area | Cross-sectional winding area of core | Weight | AL-value | Effective permeability | |
| C_1 | ℓ_e | A_e | V_e | A_{cp} | $A_{cp \text{ min.}}$ | A_{cw} | (g/set) | (nH/N ²) | (μ e) | |
| (mm ⁻¹) | (mm) | (mm ²) | (mm ³) | (mm ²) | (mm ²) | (mm ²) | | | | |
| 0.497 | 31.5 | 63.4 | 1997 | 51.6 | 47.7 | 42.1 | 12.7 | 5900±25% | 2333 | |

Measuring conditions

Coil : ϕ 0.35mm, 2UEW, 100Ts

Frequency : 1kHz

Current level : 0.5mA

Mn-Zn P series **Part No.: H5C2P22/13Z-52H**

■ SHAPES AND DIMENSIONS

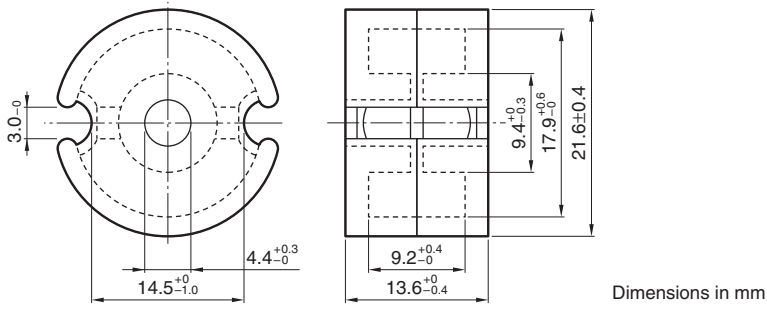

Dimensions in mm

Base on JIS C2516, IEC Publication 62317-2.

| Effective parameter | | | | | | | | Electrical characteristics | |
|---------------------|--------------------------------|-----------------------------------|-----------------------|--------------------------------------|------------------------------|--|---------|----------------------------|------------------------|
| Core factor | Effective magnetic path length | Effective cross-sectional area Ae | Effective core volume | Cross-sectional center pole area Acp | Minimum cross-sectional area | Cross-sectional winding area of core Acw | Weigh | AL-value | Effective permeability |
| C ₁ | ℓ _e | A _e | V _e | A _{cp} | A _{cp} min. | A _{cw} | (g/set) | (nH/N ²) | (μe) |
| (mm ⁻¹) | (mm) | (mm ²) | (mm ³) | (mm ²) | (mm ²) | (mm ²) | | | |
| 0.497 | 31.5 | 63.4 | 1997 | 51.6 | 47.7 | 42.1 | 12.7 | 19500±30% | 7700[at 21.7mT] |
| | | | | | | | | 16000+40/-30% | 6318*[at 0.5mT] |

Measuring conditions

Coil : ø0.35mm, 2UEW, 100Ts

Frequency : 1kHz

Current level : 0.5mA

* Reference specification when 0.5mT is applied to cores.

Mn-Zn P series **Part No.: H5AP26/16Z-52H**

■ SHAPES AND DIMENSIONS

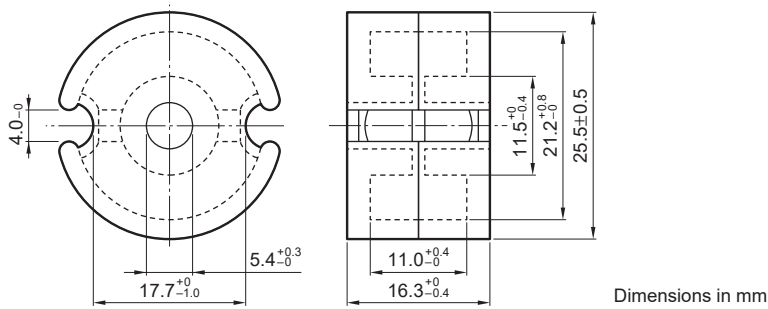

Base on JIS C2516, IEC Publication 62317-2.

| Effective parameter | | | | | | | Electrical characteristics | | |
|---------------------|--------------------------------|--------------------------------|-----------------------|----------------------------------|------------------------------|--------------------------------------|----------------------------|----------------------|------------------------|
| Core factor | Effective magnetic path length | Effective cross-sectional area | Effective core volume | Cross-sectional center pole area | Minimum cross-sectional area | Cross-sectional winding area of core | Weight | AL-value | Effective permeability |
| C_1 | ℓ_e | A_e | V_e | A_{cp} | $A_{cp \text{ min.}}$ | A_{cw} | (g/set) | (nH/N ²) | (μ e) |
| (mm ⁻¹) | (mm) | (mm ²) | (mm ³) | (mm ²) | (mm ²) | (mm ²) | | | |
| 0.40 | 37.6 | 94 | 3534 | 76.1 | 71.3 | 57.7 | 21.1 | 7800±25% | 2483 |

Measuring conditions

Coil : ϕ 0.40mm, 2UEW, 100Ts

Frequency : 1kHz

Current level : 0.5mA

Mn-Zn P series **Part No.: H5C2P26/16Z-52H**

■ SHAPES AND DIMENSIONS

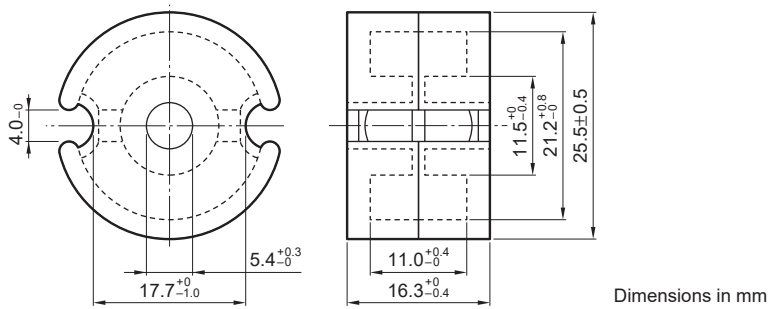

Dimensions in mm

Base on JIS C2516, IEC Publication 62317-2.

| Effective parameter | | | | | | | | Electrical characteristics | |
|---------------------|--------------------------------|--------------------------------|-----------------------|----------------------------------|------------------------------|--------------------------------------|---------|----------------------------|------------------------|
| Core factor | Effective magnetic path length | Effective cross-sectional area | Effective core volume | Cross-sectional center pole area | Minimum cross-sectional area | Cross-sectional winding area of core | Weight | AL-value | Effective permeability |
| C_1 | ℓ_e | A_e | V_e | A_{cp} | $A_{cp \text{ min.}}$ | A_{cw} | (g/set) | (nH/N ²) | (μ_e) |
| (mm ⁻¹) | (mm) | (mm ²) | (mm ³) | (mm ²) | (mm ²) | (mm ²) | | | |
| 0.40 | 37.6 | 94 | 3534 | 76.1 | 71.3 | 57.7 | 21.1 | 24500±30% | 7800[at 18.4mT] |
| | | | | | | | | 20000+40/-30% | 6367*[at 0.5mT] |

Measuring conditions

Coil : ϕ 0.40mm, 2UEW, 100Ts

Frequency : 1kHz

Current level : 0.5mA

* Reference specification when 0.5mT is applied to cores.

Mn-Zn P series **Part No.: H5AP30/19Z-52H**

■ SHAPES AND DIMENSIONS

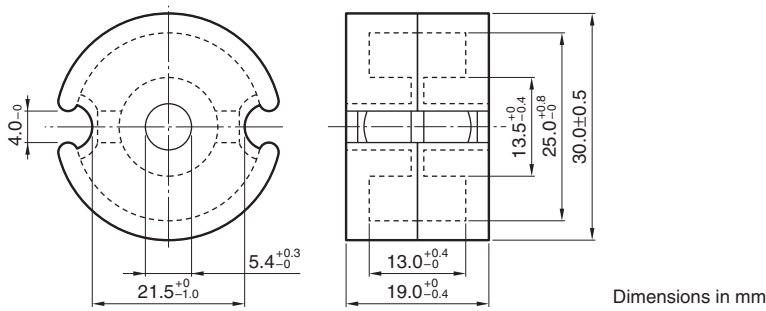

Base on JIS C2516, IEC Publication 62317-2.

| Effective parameter | | | | | | | Electrical characteristics | | | |
|---------------------|--------------------------------|--------------------------------|-----------------------|----------------------------------|------------------------------|--------------------------------------|----------------------------|----------------------|------------------------|--|
| Core factor | Effective magnetic path length | Effective cross-sectional area | Effective core volume | Cross-sectional center pole area | Minimum cross-sectional area | Cross-sectional winding area of core | Weight | AL-value | Effective permeability | |
| C_1 | ℓ_e | A_e | V_e | A_{cp} | $A_{cp \text{ min.}}$ | A_{cw} | (g/set) | (nH/N ²) | (μ_e) | |
| (mm ⁻¹) | (mm) | (mm ²) | (mm ³) | (mm ²) | (mm ²) | (mm ²) | | | | |
| 0.33 | 45.2 | 137 | 6192 | 115 | 109 | 79.9 | 35.3 | 9800±25% | 2573 | |

Measuring conditions

Coil : ϕ 0.40mm, 2UEW, 100Ts

Frequency : 1kHz

Current level : 0.5mA

Mn-Zn P series Part No.: H5C2P30/19Z-52H

SHAPES AND DIMENSIONS

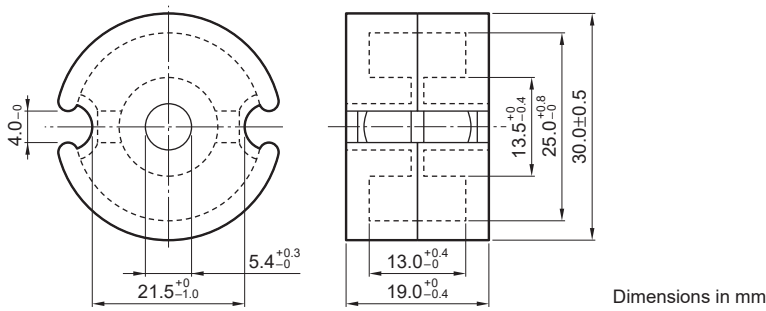

Dimensions in mm

Base on JIS C2516, IEC Publication 62317-2.

| Effective parameter | | | | | | | | Electrical characteristics | |
|---------------------|--------------------------------|--------------------------------|-----------------------|----------------------------------|------------------------------|--------------------------------------|---------|----------------------------|------------------------|
| Core factor | Effective magnetic path length | Effective cross-sectional area | Effective core volume | Cross-sectional center pole area | Minimum cross-sectional area | Cross-sectional winding area of core | Weight | AL-value | Effective permeability |
| C_1 | ℓ_e | A_e | V_e | A_{cp} | $A_{cp \text{ min.}}$ | A_{cw} | (g/set) | (nH/N ²) | (μ e) |
| (mm ⁻¹) | (mm) | (mm ²) | (mm ³) | (mm ²) | (mm ²) | (mm ²) | | | |
| 0.33 | 45.2 | 137 | 6192 | 115 | 109 | 79.9 | 35.3 | 32000±30% | 8400[at 16.5mT] |
| | | | | | | | | 25000+40/-30% | 6563*[at 0.5mT] |

Measuring conditions

Coil : ϕ 0.40mm, 2UEW, 100Ts

Frequency : 1kHz

Current level : 0.5mA

* Reference specification when 0.5mT is applied to cores.

Mn-Zn

Ferrite Cores for Telecommunication

RM series

 **REMINDERS FOR USING THESE PRODUCTS**

Please be sure to read this manual thoroughly before using the products.

The products listed on this catalog are intended for use in general electronic equipment (AV equipment, telecommunications equipment, home appliances, amusement equipment, computer equipment, personal equipment, office equipment, measurement equipment, industrial robots) under a normal operation and use condition.

The products are not designed or warranted to meet the requirements of the applications listed below, whose performance and/or quality require a more stringent level of safety or reliability, or whose failure, malfunction or trouble could cause serious damage to society, person or property.

When using the products for specific purposes, please first make confirmations in areas such as safety, reliability, and quality.

Please understand that we are not in a position to be held responsible for any damage or the like caused by any use exceeding the range or conditions of this specification sheet or by any use in the specific applications.

- | | |
|---|--|
| (1) Aerospace/Aviation equipment | (8) Public information-processing equipment |
| (2) Transportation equipment (electric trains, ships, etc.) | (9) Military equipment |
| (3) Medical equipment | (10) Electric heating apparatus, burning equipment |
| (4) Power-generation control equipment | (11) Disaster prevention/crime prevention equipment |
| (5) Atomic energy-related equipment | (12) Safety equipment |
| (6) Seabed equipment | (13) Other applications that are not considered general-purpose applications |
| (7) Transportation control equipment | |

When using this product in general-purpose standard applications, you are kindly requested to take into consideration securing protection circuit/equipment or providing backup circuits, etc to ensure higher safety.

Ferrite Cores for Telecommunication

Product compatible with RoHS directive
Halogen-free

Overview of the RM Series

FEATURES

The RM Cores have a shape that is suited to high density mounting, it possesses good shielding qualities, being laid out so that the lead groove does not create an obstruction, and enables the creation of small, high performance transformers and coils.

APPLICATION

Transformers and coils for communication devices

PART NUMBER CONSTRUCTION

| | | | | | |
|----------|-----------------|----------------------------------|---|------------------|---------------------|
| H5A | RM6 | Z | - | 5 | 2 |
| Material | Size of RM core | AL-value (Z: without air gap) | | Type of Pot core | Number of lead slot |
| H5A | RM4 | | | | |
| H5C2 | RM5 | | | | |
| | RM6 | | | | |
| | RM8 | | | | |
| | RM10 | | | | |

RANGE OF USE AND STORAGE TEMPERATURE

| Temperature range | |
|----------------------------|--------------------------|
| Operating temperature (°C) | Storage temperature (°C) |
| -30 to +105 | -30 to +85 |

- RoHS Directive Compliant Product: See the following for more details related to RoHS Directive compliant products. <http://www.tdk.co.jp/rohs/>
- Halogen-free: Indicates that Cl content is less than 900ppm, Br content is less than 900ppm, and that the total Cl and Br content is less than 1500ppm.

• All specifications are subject to change without notice.

Mn-Zn RM series **Part No.: H5ARM4Z-12**

■ SHAPES AND DIMENSIONS

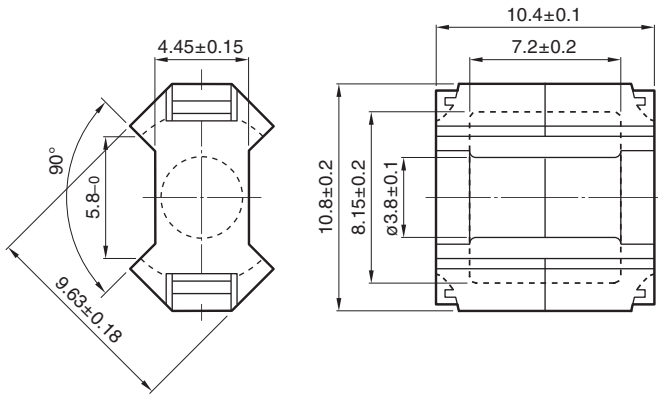

Dimensions in mm

Base on IEC Publication 60431, DIN 41980 and JIS C 2516.

| Effective parameter | | | | | | | Electrical characteristics | | |
|---------------------|--------------------------------|--------------------------------|-----------------------|----------------------------------|------------------------------|--------------------------------------|----------------------------|----------------------|------------------------|
| Core factor | Effective magnetic path length | Effective cross-sectional area | Effective core volume | Cross-sectional center pole area | Minimum cross-sectional area | Cross-sectional winding area of core | Weigh | AL-value | Effective permeability |
| C_1 | ℓ_e | A_e | V_e | A_{cp} | $A_{cp \text{ min.}}$ | A_{cw} | (g/set) | (nH/N ²) | (μe) |
| (mm ⁻¹) | (mm) | (mm ²) | (mm ³) | (mm ²) | (mm ²) | (mm ²) | | | |
| 1.62 | 22.7 | 14.0 | 318 | 11.3 | 10.7 | 15.6 | 1.7 | 1240±25% | 1599 |

Measuring conditions

Coil : $\phi 0.18$ mm, 2UEW, 100Ts

Frequency : 1kHz

Current level : 0.5mA

Mn-Zn RM series Part No.: H5C2RM4Z-12

SHAPES AND DIMENSIONS

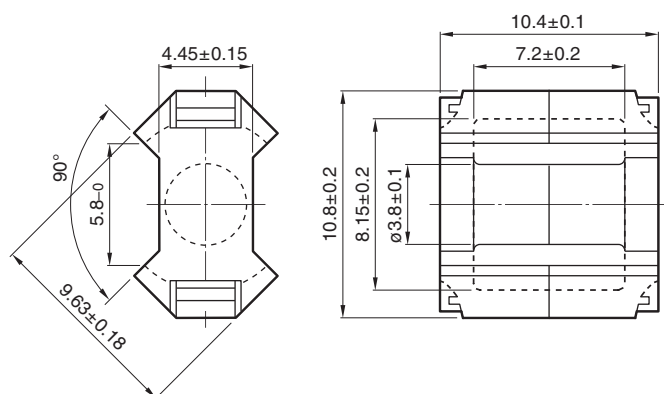

Dimensions in mm

Base on IEC Publication 60431, DIN 41980 and JIS C 2516.

| Effective parameter | | | | | | | | Electrical characteristics | |
|---------------------|--------------------------------|--------------------------------|-----------------------|----------------------------------|------------------------------|--------------------------------------|---------|----------------------------|------------------------|
| Core factor | Effective magnetic path length | Effective cross-sectional area | Effective core volume | Cross-sectional center pole area | Minimum cross-sectional area | Cross-sectional winding area of core | Weight | AL-value | Effective permeability |
| C_1 | ℓ_e | A_e | V_e | A_{cp} | $A_{cp \text{ min.}}$ | A_{cw} | (g/set) | (nH/N ²) | (μe) |
| (mm ⁻¹) | (mm) | (mm ²) | (mm ³) | (mm ²) | (mm ²) | (mm ²) | | | |
| 1.62 | 22.7 | 14.0 | 318 | 11.3 | 10.7 | 15.6 | 1.7 | 4950±30% | 6381[at 32.4mT] |
| | | | | | | | | 3000+40/-30% | 3870*[at 0.5mT] |

Measuring conditions

Coil : ϕ 0.18mm, 2UEW, 100Ts

Frequency : 1kHz

Current level : 0.5mA

* Reference specification when 0.5mT is applied to cores.

Mn-Zn RM series **Part No.: H5ARM5Z-12**

■ SHAPES AND DIMENSIONS

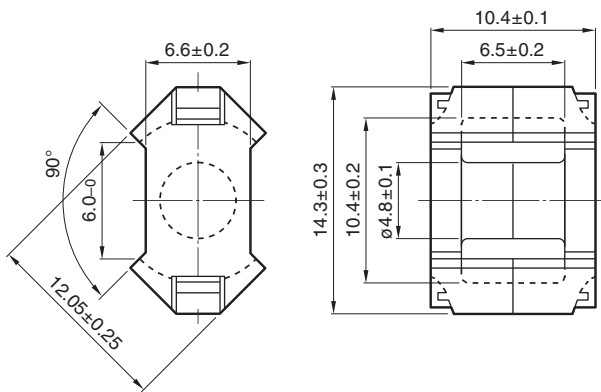

Dimensions in mm

Base on IEC Publication 60431, DIN 41980 and JIS C 2516.

| Effective parameter | | | | | | | Electrical characteristics | | |
|---------------------|--------------------------------|--------------------------------|-----------------------|----------------------------------|------------------------------|--------------------------------------|----------------------------|----------------------|------------------------|
| Core factor | Effective magnetic path length | Effective cross-sectional area | Effective core volume | Cross-sectional center pole area | Minimum cross-sectional area | Cross-sectional winding area of core | Weight | AL-value | Effective permeability |
| C_1 | ℓ_e | A_e | V_e | A_{cp} | $A_{cp \text{ min.}}$ | A_{cw} | (g/set) | (nH/N ²) | (μ_e) |
| (mm ⁻¹) | (mm) | (mm ²) | (mm ³) | (mm ²) | (mm ²) | (mm ²) | | | |
| 0.940 | 22.4 | 23.7 | 530 | 18.1 | 17.3 | 18.2 | 3.0 | 2220±25% | 1661 |

Measuring conditions

Coil : ϕ 0.20mm, 2UEW, 100Ts

Frequency : 1kHz

Current level : 0.5mA

Mn-Zn RM series **Part No.: H5C3RM5Z-12**

■ SHAPES AND DIMENSIONS

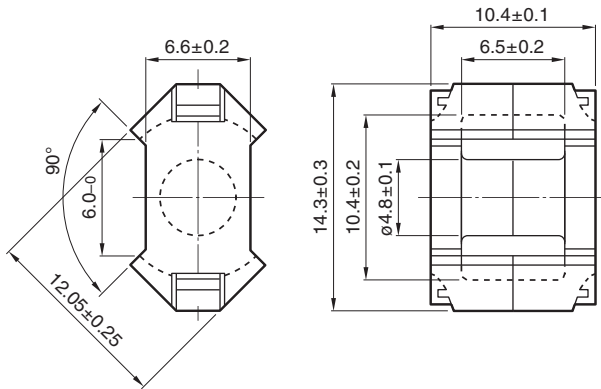

Dimensions in mm

Base on IEC Publication 60431, DIN 41980 and JIS C 2516.

| Effective parameter | | | | | | | Electrical characteristics | | |
|---------------------|--------------------------------|--------------------------------|-----------------------|----------------------------------|------------------------------|--------------------------------------|----------------------------|----------------------|------------------------|
| Core factor | Effective magnetic path length | Effective cross-sectional area | Effective core volume | Cross-sectional center pole area | Minimum cross-sectional area | Cross-sectional winding area of core | Weight | AL-value | Effective permeability |
| C_1 | ℓ_e | A_e | V_e | A_{cp} | $A_{cp \text{ min.}}$ | A_{cw} | (g/set) | (nH/N ²) | (μ_e) |
| (mm ⁻¹) | (mm) | (mm ²) | (mm ³) | (mm ²) | (mm ²) | (mm ²) | | | |
| 0.940 | 22.4 | 23.7 | 530 | 18.1 | 17.3 | 18.2 | 3.0 | 7700 min.* | 5760 min.* |

Measuring conditions

Coil : ϕ 0.20mm, 2UEW, 100Ts

Frequency : 10kHz

Current level : 0.5mA

Voltage: 10mV

* All specifications are subject to change without notice.

Mn-Zn RM series **Part No.: H5ARM6Z-12**

■ SHAPES AND DIMENSIONS

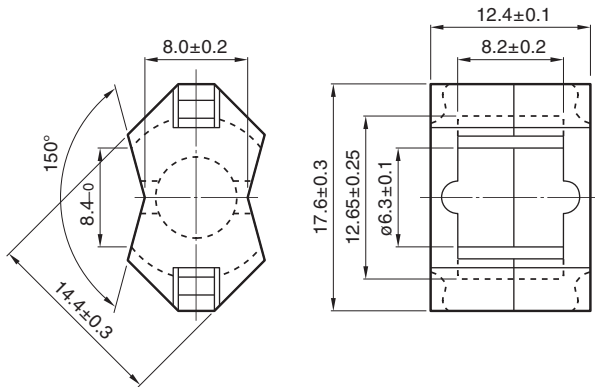

Dimensions in mm

Base on IEC Publication 60431, DIN 41980 and JIS C 2516.

| Effective parameter | | | | | | | Electrical characteristics | | |
|---------------------|--------------------------------|-----------------------------------|-----------------------|--------------------------------------|------------------------------|--|----------------------------|----------------------|------------------------|
| Core factor | Effective magnetic path length | Effective cross-sectional area Ae | Effective core volume | Cross-sectional center pole area Acp | Minimum cross-sectional area | Cross-sectional winding area of core Acw | Weigh | AL-value | Effective permeability |
| C ₁ | ℓ _e | A _e | V _e | A _{cp} | A _{cp min.} | A _{cw} | (g/set) | (nH/N ²) | (μe) |
| (mm ⁻¹) | (mm) | (mm ²) | (mm ³) | (mm ²) | (mm ²) | (mm ²) | | | |
| 0.781 | 28.6 | 36.6 | 1050 | 31.2 | 30.2 | 26.0 | 5.5 | 3300±25% | 2258 |

Measuring conditions

Coil : ø0.26mm, 2UEW, 100Ts

Frequency : 1kHz

Current level : 0.5mA

Mn-Zn RM series **Part No.: H5C3RM6Z-12**

■ SHAPES AND DIMENSIONS

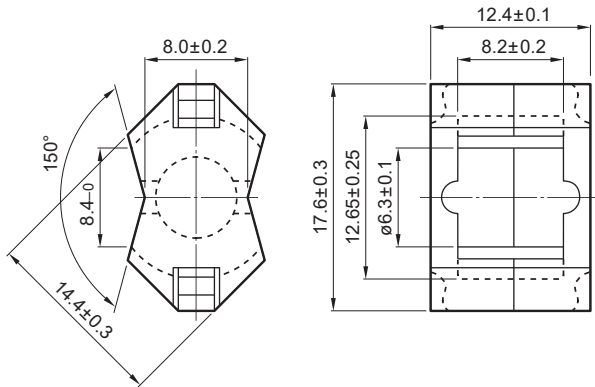

Dimensions in mm

Base on IEC Publication 60431, DIN 41980 and JIS C 2516.

| Effective parameter | | | | | | | Electrical characteristics | | |
|---------------------|--------------------------------|-----------------------------------|-----------------------|--------------------------------------|------------------------------|--|----------------------------|----------------------|------------------------|
| Core factor | Effective magnetic path length | Effective cross-sectional area Ae | Effective core volume | Cross-sectional center pole area Acp | Minimum cross-sectional area | Cross-sectional winding area of core Acw | Weigh | AL-value | Effective permeability |
| C ₁ | ℓ _e | A _e | V _e | A _{cp} | A _{cp min.} | A _{cw} | (g/set) | (nH/N ²) | (μe) |
| (mm ⁻¹) | (mm) | (mm ²) | (mm ³) | (mm ²) | (mm ²) | (mm ²) | | | |
| 0.781 | 28.6 | 36.6 | 1050 | 31.2 | 30.2 | 26.0 | 5.5 | 9100 min.* | 5648 min.* |

Measuring conditions

Coil : ø0.26mm, 2UEW, 100Ts

Frequency : 10kHz

Current level : 0.5mA

Voltage: 10mV

* All specifications are subject to change without notice.

Mn-Zn RM series **Part No.: H5ARM8Z-12**

■ SHAPES AND DIMENSIONS

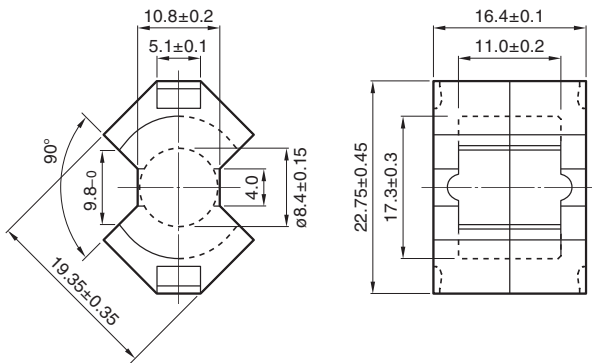

Dimensions in mm

Base on IEC Publication 60431, DIN 41980 and JIS C 2516.

| Effective parameter | | | | | | | Electrical characteristics | | |
|---------------------|--------------------------------|--------------------------------|-----------------------|----------------------------------|------------------------------|--------------------------------------|----------------------------|----------------------|------------------------|
| Core factor | Effective magnetic path length | Effective cross-sectional area | Effective core volume | Cross-sectional center pole area | Minimum cross-sectional area | Cross-sectional winding area of core | Weigh | AL-value | Effective permeability |
| C_1 | ℓ_e | A_e | V_e | A_{cp} | $A_{cp \text{ min.}}$ | A_{cw} | (g/set) | (nH/N ²) | (μe) |
| (mm ⁻¹) | (mm) | (mm ²) | (mm ³) | (mm ²) | (mm ²) | (mm ²) | | | |
| 0.594 | 38.0 | 64.0 | 2430 | 55.4 | 53.3 | 48.9 | 13 | 4300±25% | 2019 |

Measuring conditions

Coil : $\phi 0.40$ mm, 2UEW, 100Ts

Frequency : 1kHz

Current level : 0.5mA

• All specifications are subject to change without notice.

Mn-Zn RM series **Part No.: H5C2RM8Z-12**

■ SHAPES AND DIMENSIONS

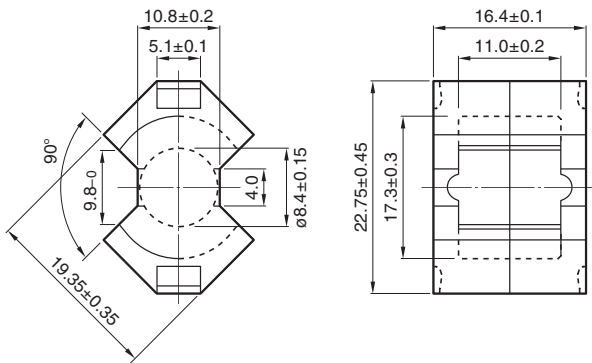

Dimensions in mm

Base on IEC Publication 60431, DIN 41980 and JIS C 2516.

| Effective parameter | | | | | | | | Electrical characteristics | |
|---------------------|--------------------------------|--------------------------------|-----------------------|----------------------------------|------------------------------|--------------------------------------|---------|----------------------------|------------------------|
| Core factor | Effective magnetic path length | Effective cross-sectional area | Effective core volume | Cross-sectional center pole area | Minimum cross-sectional area | Cross-sectional winding area of core | Weight | AL-value | Effective permeability |
| C_1 | ℓ_e | A_e | V_e | A_{cp} | $A_{cp \text{ min.}}$ | A_{cw} | (g/set) | (nH/N ²) | (μ_e) |
| (mm ⁻¹) | (mm) | (mm ²) | (mm ³) | (mm ²) | (mm ²) | (mm ²) | | | |
| 0.594 | 38.0 | 64.0 | 2430 | 55.4 | 53.3 | 48.9 | 13 | 17100±30% | 8029[at 20.3mT] |
| | | | | | | | | 15200+40/-30% | 7137*[at 0.5mT] |

Measuring conditions

Coil : ϕ 0.40mm, 2UEW, 100Ts

Frequency : 1kHz

Current level : 0.5mA

* Reference specification when 0.5mT is applied to cores.

Mn-Zn RM series **Part No.: H5ARM10Z-12**

■ SHAPES AND DIMENSIONS

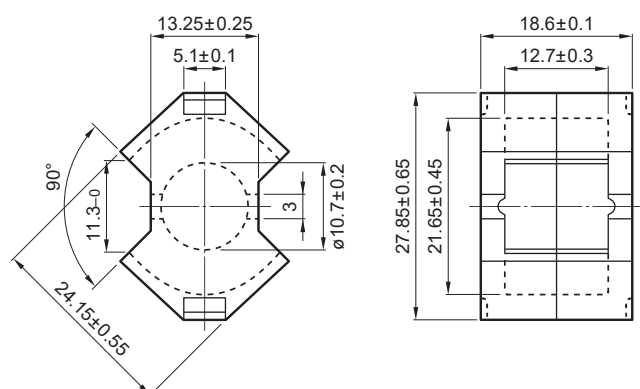

Dimensions in mm

Base on IEC Publication 60431, DIN 41980 and JIS C 2516.

| Effective parameter | | | | | | | Electrical characteristics | | |
|---------------------|--------------------------------|---|-----------------------|--|---|--|----------------------------|----------------------|------------------------|
| Core factor | Effective magnetic path length | Effective cross-sectional area A_e | Effective core volume | Cross-sectional center pole area A_{cp} | Minimum cross-sectional area $A_{cp \text{ min.}}$ | Cross-sectional winding area of core A_{cw} | Weigh | AL-value | Effective permeability |
| C_1 | ℓ_e | A_e | V_e | A_{cp} | $A_{cp \text{ min.}}$ | A_{cw} | (g/set) | (nH/N ²) | (μ_e) |
| (mm ⁻¹) | (mm) | (mm ²) | (mm ³) | (mm ²) | (mm ²) | (mm ²) | | | |
| 0.450 | 44.0 | 98.0 | 4310 | 89.9 | 86.6 | 69.5 | 23 | 6220±25% | 2475 |

Measuring conditions

Coil : $\varnothing 0.40$ mm, 2UEW, 100Ts

Frequency : 1kHz

Current level : 0.5mA

Mn-Zn RM series **Part No.: H5C2RM10Z-12**

■ SHAPES AND DIMENSIONS

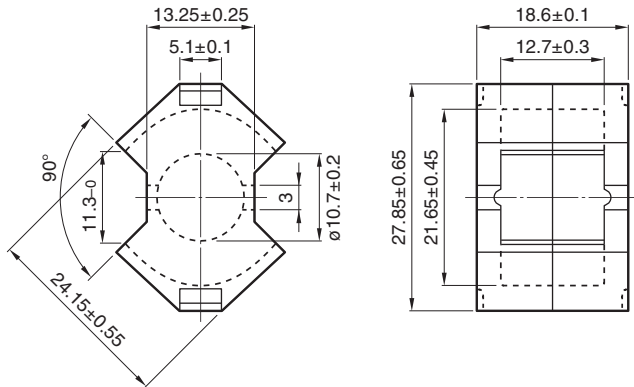

Dimensions in mm

Base on IEC Publication 60431, DIN 41980 and JIS C 2516.

| Effective parameter | | | | | | | | Electrical characteristics | |
|---------------------|--------------------------------|-----------------------------------|-----------------------|--------------------------------------|---------------------------------------|--|---------|----------------------------|------------------------|
| Core factor | Effective magnetic path length | Effective cross-sectional area Ae | Effective core volume | Cross-sectional center pole area Acp | Minimum cross-sectional area Acp min. | Cross-sectional winding area of core Acw | Weigh | AL-value | Effective permeability |
| C ₁ | ℓ _e | A _e | V _e | A _{cp} | A _{cp min.} | A _{cw} | (g/set) | (nH/N ²) | (μe) |
| 0.450 | 44.0 | 98.0 | 4310 | 89.9 | 86.6 | 69.5 | 23 | 20900±30% | 8316[at 17.8mT] |
| | | | | | | | | 17500+40/-30% | 6963*[at 0.5mT] |

Measuring conditions

Coil : ø0.40mm, 2UEW, 100Ts

Frequency : 1kHz

Current level : 0.5mA

* Reference specification when 0.5mT is applied to cores.

Mn-Zn

Ferrite Cores for Telecommunication

T series

**REMINDERS FOR USING THESE PRODUCTS**

Please be sure to read this manual thoroughly before using the products.

The products listed on this catalog are intended for use in general electronic equipment (AV equipment, telecommunications equipment, home appliances, amusement equipment, computer equipment, personal equipment, office equipment, measurement equipment, industrial robots) under a normal operation and use condition.

The products are not designed or warranted to meet the requirements of the applications listed below, whose performance and/or quality require a more stringent level of safety or reliability, or whose failure, malfunction or trouble could cause serious damage to society, person or property.

When using the products for specific purposes, please first make confirmations in areas such as safety, reliability, and quality.

Please understand that we are not in a position to be held responsible for any damage or the like caused by any use exceeding the range or conditions of this specification sheet or by any use in the specific applications.

- | | |
|---|--|
| (1) Aerospace/Aviation equipment | (8) Public information-processing equipment |
| (2) Transportation equipment (electric trains, ships, etc.) | (9) Military equipment |
| (3) Medical equipment | (10) Electric heating apparatus, burning equipment |
| (4) Power-generation control equipment | (11) Disaster prevention/crime prevention equipment |
| (5) Atomic energy-related equipment | (12) Safety equipment |
| (6) Seabed equipment | (13) Other applications that are not considered general-purpose applications |
| (7) Transportation control equipment | |

When using this product in general-purpose standard applications, you are kindly requested to take into consideration securing protection circuit/equipment or providing backup circuits, etc to ensure higher safety.

Ferrite Cores for Telecommunication

Product compatible with RoHS directive
Halogen-free

Overview of the T Series

FEATURES

- Select from five high permeability materials of $\mu_i=4000, 5000, 7500, 10000, 15000$ to match the frequency band used.
- Paraxylene coating (Small T Core only) and epoxy coating are available.

APPLICATION

Pulse Transformers, Coils, Current Sensors

PART NUMBER CONSTRUCTION

For general use

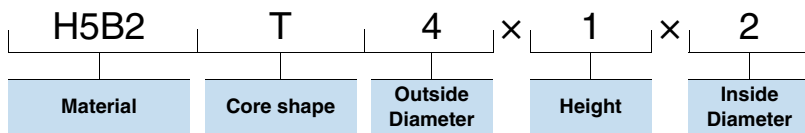

RANGE OF USE AND STORAGE TEMPERATURE

| Temperature range | |
|----------------------------|--------------------------|
| Operating temperature (°C) | Storage temperature (°C) |
| -30 to +105 | -30 to +85 |

RoHS Directive Compliant Product: See the following for more details. <https://product.tdk.com/info/en/environment/rohs/index.html>

Please be sure to request delivery specifications that provide further details on the features and specifications of the products for proper and safe use. Please note that the contents may change without any prior notice due to reasons such as upgrading.

Mn-Zn For general use



SHAPES AND DIMENSIONS

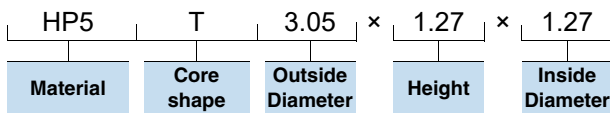
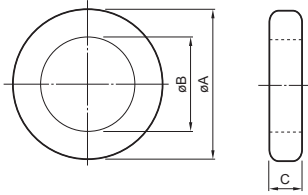

If epoxy or paraxylene-coated products are desired, please suffix P or E to part No. when ordering.
 Above T10 (outside diameter 10mm min.): Epoxy Coating "E"
 Up to T8 (outside diameter 8mm max.): Paraxylene "P"

| Part No. | Effective parameter | | | Effective parameter | | | Electrical characteristics | |
|---|---------------------|------|------|--|--|--|---|--|
| | øA (mm) | øB | C | Core factor C ₁ (mm ⁻¹) | Effective cross-sectional area A _e (mm ²) | Effective magnetic path length l _e (mm) | A _L -value (nH/N ²) | Measuring conditions |
| HP5 T3.05×1.27×1.27 H5B2 T3.05×1.27×1.27 H5C3 T3.05×1.27×1.27 | 3.05 | 1.27 | 1.27 | 5.65 | 1.06 | 5.99 | 1100±20% 1700±25% 3340±30% | 10kHz, 10mV, 5Ts 10kHz, 10mV, 5Ts 10kHz, 10mV, 5Ts |
| HP5 T4×1×2 H5B2 T4×1×2 H5C3 T4×1×2 | 4.00 | 2.00 | 1.00 | 9.06 | 0.961 | 8.71 | 670±20% 1000±25% 2000±30% | 10kHz, 10mV, 5Ts 10kHz, 10mV, 5Ts 10kHz, 10mV, 5Ts |
| HP5 T3.94×1.27×2.23 H5B2 T3.94×1.27×2.23 H5C3 T3.94×1.27×2.23 | 3.94 | 2.23 | 1.27 | 8.69 | 1.06 | 9.19 | 720±20% 1080±25% 2170±30% | 10kHz, 10mV, 5Ts 10kHz, 10mV, 5Ts 10kHz, 10mV, 5Ts |
| HP5 T4.83×1.27×2.29 H5B2 T4.83×1.27×2.29 H5C3 T4.83×1.27×2.29 | 4.83 | 2.29 | 1.27 | 6.63 | 1.54 | 10.2 | 950±20% 1400±25% 2840±30% | 10kHz, 10mV, 5Ts 10kHz, 10mV, 5Ts 10kHz, 10mV, 5Ts |
| HP5 T6×1.5×3 H5B2 T6×1.5×3 H5C3 T6×1.5×3 | 6.00 | 3.00 | 1.50 | 6.04 | 2.16 | 13.1 | 1000±20% 1500±25% 3000±30% | 10kHz, 10mV, 5Ts 10kHz, 10mV, 5Ts 10kHz, 10mV, 5Ts |
| HP5 T5.84×1.52×3.05 H5B2 T5.84×1.52×3.05 H5C3 T5.84×1.52×3.05 | 5.84 | 3.05 | 1.52 | 6.34 | 2.05 | 13.0 | 990±20% 1480±25% 2960±30% | 10kHz, 10mV, 5Ts 10kHz, 10mV, 5Ts 10kHz, 10mV, 5Ts |
| HP5 T8×2×4 H5B2 T8×2×4 H5C3 T8×2×4 | 8.00 | 4.00 | 2.00 | 4.53 | 3.84 | 17.4 | 1330±20% 2000±25% 4000±30% | 10kHz, 10mV, 5Ts 10kHz, 10mV, 5Ts 10kHz, 10mV, 5Ts |
| HP5 T10×2.5×5 H5B2 T10×2.5×5 H5C3 T10×2.5×5 | 10.0 | 5.00 | 2.50 | 3.63 | 6.01 | 21.8 | 1670±20% 2500±25% 5000±30% | 10kHz, 10mV, 5Ts 10kHz, 10mV, 5Ts 10kHz, 10mV, 5Ts |
| H5A T12×3×6 H5C2 T12×3×6 | 12.0 | 6.00 | 3.00 | 3.02 | 8.65 | 26.1 | 1400±25% 3600±25% | 50kHz, 10mV, 10Ts 10kHz, 10mV, 5Ts |
| H5A T14×3.5×7 H5C2 T14×3.5×7 | 14.0 | 7.00 | 3.50 | 2.59 | 11.8 | 30.5 | 1650±25% 4200±25% | 50kHz, 10mV, 10Ts 10kHz, 10mV, 5Ts |
| H5A T20×5×10 H5C2 T20×5×10 | 20.0 | 10.0 | 5.00 | 1.81 | 24.0 | 43.6 | 2350±25% 6000±30% | 50kHz, 10mV, 10Ts 10kHz, 10mV, 5Ts |
| H5A T20×7.5×14.5 H5C2 T20×7.5×14.5 | 20.0 | 14.5 | 7.50 | 2.61 | 20.4 | 53.3 | 1800±25% 4100±30% | 50kHz, 10mV, 10Ts 10kHz, 10mV, 5Ts |
| H5C2 T28×13×16 | 28.0 | 16.0 | 13.0 | 0.864 | 76.0 | 65.6 | 14000±30% | 10kHz, 10mV, 5Ts |
| H5C2 T31×8×19 | 31.0 | 19.0 | 8.00 | 1.60 | 47.1 | 75.5 | 7700±30% | 10kHz, 10mV, 5Ts |
| H5C2 T38×14×22 | 38.0 | 22.0 | 14.0 | 0.821 | 109 | 89.7 | 13160±30% | 10kHz, 10mV, 5Ts |
| H5C2 T44.5×13×30 | 44.5 | 30.0 | 13.0 | 1.23 | 93.0 | 114 | 10000±30% | 10kHz, 10mV, 5Ts |

- Can be coated with epoxy or paraxylene.
- Insulation withstanding voltage of coating product: DC.1000V min. for 1 second.

⚠ Please be sure to request delivery specifications that provide further details on the features and specifications of the products for proper and safe use.
 Please note that the contents may change without any prior notice due to reasons such as upgrading.

Mn-Zn

Large Size Ferrite Cores for High Power

E series

EC
EIC
EE
EI
ETD

**REMINDERS FOR USING THESE PRODUCTS**

Please be sure to read this manual thoroughly before using the products.

The products listed on this catalog are intended for use in general electronic equipment (AV equipment, telecommunications equipment, home appliances, amusement equipment, computer equipment, personal equipment, office equipment, measurement equipment, industrial robots) under a normal operation and use condition.

The products are not designed or warranted to meet the requirements of the applications listed below, whose performance and/or quality require a more stringent level of safety or reliability, or whose failure, malfunction or trouble could cause serious damage to society, person or property.

When using the products for specific purposes, please first make confirmations in areas such as safety, reliability, and quality.

Please understand that we are not in a position to be held responsible for any damage or the like caused by any use exceeding the range or conditions of this specification sheet or by any use in the specific applications.

- | | |
|---|--|
| (1) Aerospace/Aviation equipment | (8) Public information-processing equipment |
| (2) Transportation equipment (electric trains, ships, etc.) | (9) Military equipment |
| (3) Medical equipment | (10) Electric heating apparatus, burning equipment |
| (4) Power-generation control equipment | (11) Disaster prevention/crime prevention equipment |
| (5) Atomic energy-related equipment | (12) Safety equipment |
| (6) Seabed equipment | (13) Other applications that are not considered general-purpose applications |
| (7) Transportation control equipment | |

When using this product in general-purpose standard applications, you are kindly requested to take into consideration securing protection circuit/equipment or providing backup circuits, etc to ensure higher safety.

Large Size Ferrite Cores for High Power

Product compatible with RoHS directive
Halogen-free

Overview of the E Series

FEATURES

- Large size cores for transformers with large power outputs.
- Can also be used in reactors.

APPLICATION

- Large size industrial equipment, transformers for consumer equipment
- Reactors

PART NUMBER CONSTRUCTION

| PE22 | EC | 70 | × | 69 | × | 16 |
|----------|------------|-------|---|-----------|---|-----------------|
| Material | Core shape | Width | | Thickness | | Inside Diameter |
| PE22 | EC | 70 | | 69 | | 16 |
| PC40 | EIC | 90 | | 90 | | 30 |
| PC95 | EE | 80 | | 101 | | 19 |
| PEL95 | EI | 120 | | 46 | | 20 |
| PEM95 | ETD | | | 55 | | 31N |
| | | | | 65 | | |
| | | | | 91 | | |
| | | | | 76 | | |
| | | | | 56 | | |
| | | | | 108 | | |
| | | | | 64 | | |

RANGE OF USE AND STORAGE TEMPERATURE

| Temperature range | |
|----------------------------|--------------------------|
| Operating temperature (°C) | Storage temperature (°C) |
| -30 to +105 | -30 to +85 |

- RoHS Directive Compliant Product: See the following for more details. <https://product.tdk.com/info/en/environment/rohs/index.html>
- Halogen-free: Indicates that Cl content is less than 900ppm, Br content is less than 900ppm, and that the total Cl and Br content is less than 1500ppm.

Please be sure to request delivery specifications that provide further details on the features and specifications of the products for proper and safe use. Please note that the contents may change without any prior notice due to reasons such as upgrading.

Mn-Zn EC Cores



SHAPES AND DIMENSIONS

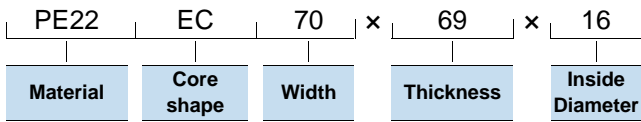
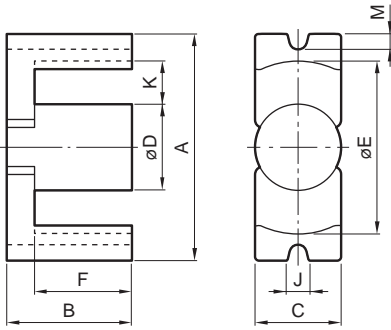

| Material | Part No. Shape Dimensions | Dimensions (mm) | | | | | | | | | | |
|----------|------------------------------|-----------------|-----------|----------|----------|----------|----------|-----|------|---------|------|------------------------|
| | | A | Bx2 | C | φD | φE | Fx2 | M | J | R | K | Kx2F(mm ²) |
| PE22 | EC70x69X16 | 70.0±1.7 | 69.0±1.0 | 16.4±0.5 | 16.4±0.5 | 43.3min. | 45.5±1.0 | 52 | 4.75 | 1max. | 14.1 | 639 |
| PC40 | | | | | | | | | | | | |
| PC95 | | | | | | | | | | | | |
| PEL95 | | | | | | | | | | | | |
| PEM95 | | | | | | | | | | | | |
| PE22 | EC90x90X30 | 90.0±1.8 | 90.0±1.3 | 30.0±1.0 | 30.0±1.0 | 68.5min. | 71.0±1.0 | 5.5 | 6.00 | 1max. | 20.0 | 1420 |
| PC40 | | | | | | | | | | | | |
| PC95 | | | | | | | | | | | | |
| PEL95 | | | | | | | | | | | | |
| PEM95 | | | | | | | | | | | | |
| PE22 | EC120x101X30 | 120.0±2.0 | 101.0±1.3 | 30.0±1.0 | 30.0±1.0 | 93.3min. | 71.0±1.0 | 5.5 | 6.03 | 1.5max. | 32.5 | 2307 |
| PC40 | | | | | | | | | | | | |
| PC95 | | | | | | | | | | | | |
| PEL95 | | | | | | | | | | | | |
| PEM95 | | | | | | | | | | | | |

⚠ Please be sure to request delivery specifications that provide further details on the features and specifications of the products for proper and safe use.
Please note that the contents may change without any prior notice due to reasons such as upgrading.

Mn-Zn EC Cores

| Material | Part No. Shape Dimensions | Effective parameter Core factor | | Effective cross-sectional area Ae (mm ²) | Effective magnetic path length Le (mm) | Effective core volume Ve (mm ³) | Weigh (Approx.) (g) | Electrical characteristics AL-value (nH/N ²) 1kHz, 0.4A/m 23 °C |
|----------|------------------------------|------------------------------------|---|---|---|--|------------------------|---|
| | | C1 (mm ⁻¹) | C2 x 10 ⁻² (mm ⁻³) | | | | | |
| PE22 | EC70x69X16 | 0.5138891 | 0.18322 | 280 | 144 | 40420 | 250 | 3910±25% |
| PC40 | | | | | | | | 4845±25% |
| PC95 | | | | | | | | — |
| PEL95 | | | | | | | | — |
| PEM95 | | | | | | | | — |
| PE22 | EC90x90X30 | 0.353338 | 0.05648 | 626 | 221 | 138270 | 635 | 5925±25% |
| PC40 | | | | | | | | 7415±25% |
| PC95 | | | | | | | | 9000 * |
| PEL95 | | | | | | | | 10300 * |
| PEM95 | | | | | | | | 8400 * |
| PE22 | EC120x101X30 | 0.3300745 | 0.04278 | 772 | 255 | 196490 | 986 | 6395±25% |
| PC40 | | | | | | | | 8025±25% |
| PC95 | | | | | | | | — |
| PEL95 | | | | | | | | — |
| PEM95 | | | | | | | | — |

* Typ. value for no specification tolerance

□ Core loss Temperature characteristics (Typ.)

EC90x90X30 at 25kHz,200mT

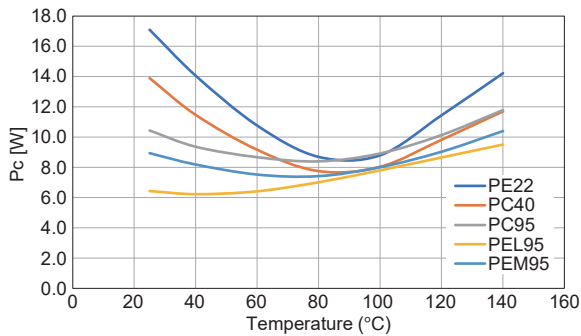

⚠ Please be sure to request delivery specifications that provide further details on the features and specifications of the products for proper and safe use. Please note that the contents may change without any prior notice due to reasons such as upgrading.

Mn-Zn EC series Part No.: PE22 EC70X69X16

SHAPES AND DIMENSIONS

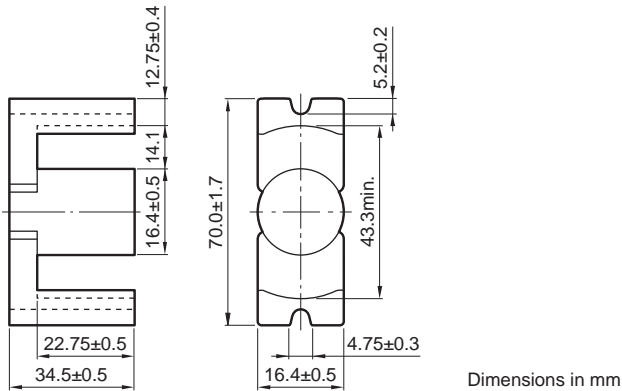

| Effective parameter | | | | | | | | | Electrical characteristics |
|------------------------------|---|--------------------------------|--------------------------------|-----------------------------|----------------------------------|-----------------------------------|--------------------------------|-----------------|--|
| Core factor | | Effective magnetic path length | Effective cross-sectional area | Effective core volume | Cross-sectional center pole area | Minimum cross-sectional area | Winding cross-sectional area | Weigh (approx.) | AL-value |
| C_1 (mm ⁻¹) | $C_2 \times 10^{-2}$ (mm ⁻³) | l_e (mm) | A_e (mm ²) | V_e (mm ³) | A_c (mm ²) | A_{min}^* (mm ²) | A_{cw} (mm ²) | (g) | (nH/N ²) 1kHz 0.4A/m 23°C |
| 0.5138891 | 0.18322 | 144 | 280 | 40420 | 211 | 211C* | 642 | 250 | 3910±25% |

* The symbol followed A min. value shows minimum cross-sectional area part.

L is outer pole part, B is the back part.

○ Calculated output power (forward converter mode): 1.1kW (100kHz)

NI limit vs. AL-value

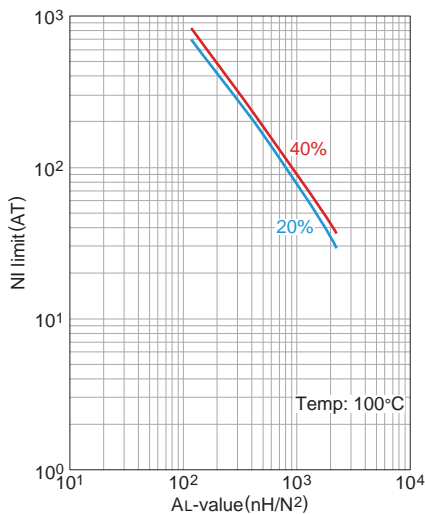

The 20% and 40% graph shows when a 20% and 40% drop from the initial AL-value has been made due to the DC superimposition.

AL-value vs. Air gap length

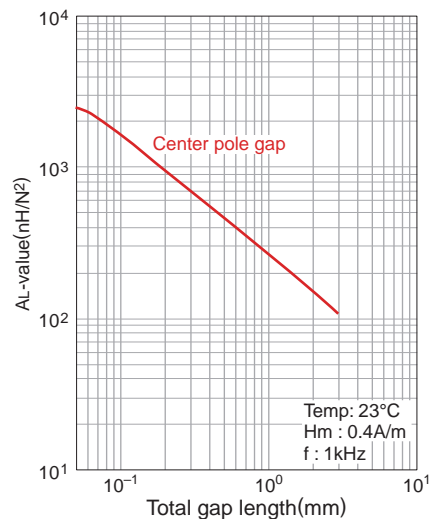

Mn-Zn EC series Part No.: PC40 EC70X69X16

SHAPES AND DIMENSIONS

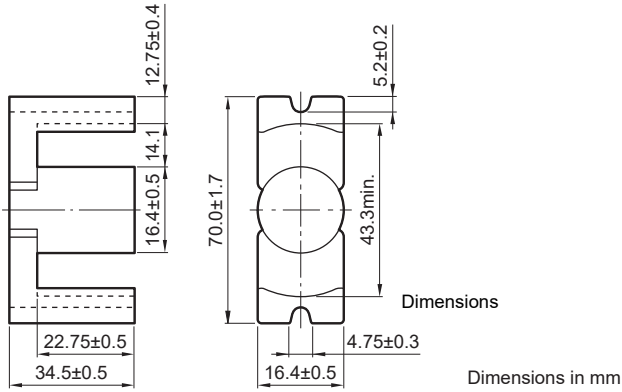

| Effective parameter | | | | | | | | | Electrical characteristics |
|------------------------------|---|--------------------------------|--------------------------------|-----------------------------|----------------------------------|------------------------------------|--------------------------------|-----------------|--|
| Core factor | | Effective magnetic path length | Effective cross-sectional area | Effective core volume | Cross-sectional center pole area | Minimum cross-sectional area | Winding cross-sectional area | Weigh (approx.) | AL-value |
| C_1 (mm ⁻¹) | $C_2 \times 10^{-2}$ (mm ⁻³) | l_e (mm) | A_e (mm ²) | V_e (mm ³) | A_c (mm ²) | $A_{min.}^*$ (mm ²) | A_{cw} (mm ²) | (g) | (nH/N ²) 1kHz 0.4A/m 23°C |
| 0.5138891 | 0.18322 | 144 | 280 | 40420 | 211 | 211C* | 642 | 250 | 4845±25% |

* The symbol followed A min. value shows minimum cross-sectional area part.

L is outer pole part, B is the back part.

○ Calculated output power (forward converter mode): 1.2kW (100kHz)

NI limit vs. AL-value

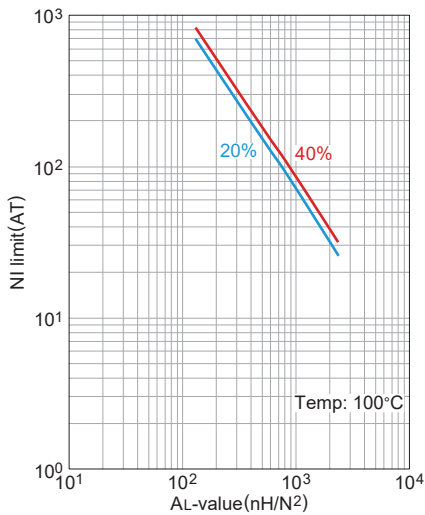

The 20% and 40% graph shows when a 20% and 40% drop from the initial AL-value has been made due to the DC superimposition.

AL-value vs. Air gap length

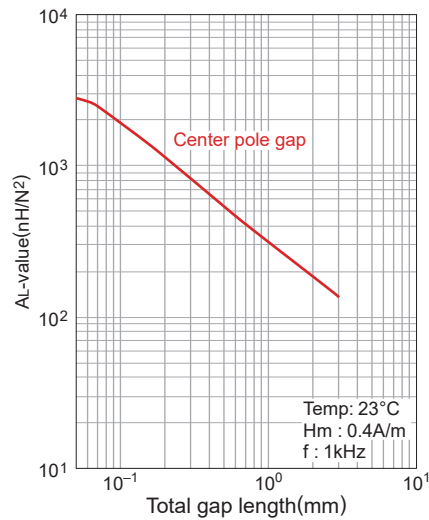

⚠ Please be sure to request delivery specifications that provide further details on the features and specifications of the products for proper and safe use. Please note that the contents may change without any prior notice due to reasons such as upgrading.

Mn-Zn EC series Part No.: PE22 EC90X90X30

SHAPES AND DIMENSIONS

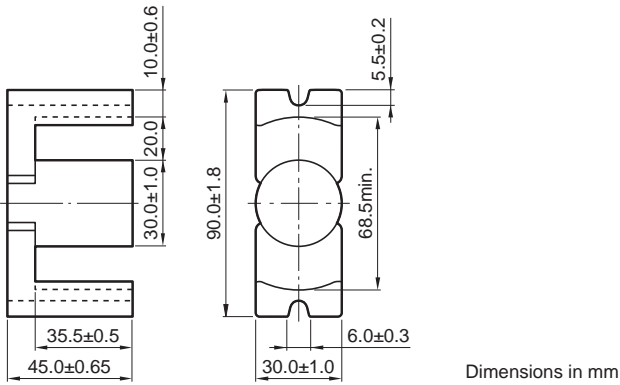

| Effective parameter | | | | | | | | | Electrical characteristics |
|------------------------------|---|---|---|--|---|--|--|------------------------|--|
| Core factor | | Effective magnetic path length l_e (mm) | Effective cross-sectional area A_e (mm ²) | Effective core volume V_e (mm ³) | Cross-sectional center pole area A_c (mm ²) | Minimum cross-sectional area $A_{min.}^*$ (mm ²) | Winding cross-sectional area A_{cw} (mm ²) | Weigh (approx.) (g) | AL-value (nH/N ²) 1kHz 0.4A/m 23°C |
| C_1 (mm ⁻¹) | $C_2 \times 10^{-2}$ (mm ⁻³) | | | | | | | | |
| 0.3533380 | 0.05648 | 221 | 626 | 138270 | 707 | 570B* | 1420 | 635 | 5925±25% |

* The symbol followed A min. value shows minimum cross-sectional area part.

C is center pole part, L is outer pole part, B is the back part.

○ Calculated output power (forward converter mode): 3.2kW (100kHz)

NI limit vs. AL-value

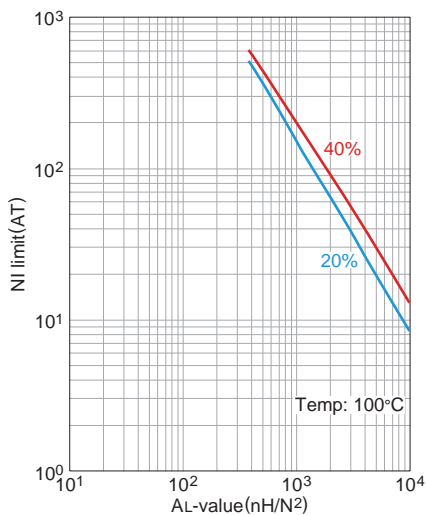

The 20% and 40% graph shows when a 20% and 40% drop from the initial AL-value has been made due to the DC superimposition.

AL-value vs. Air gap length

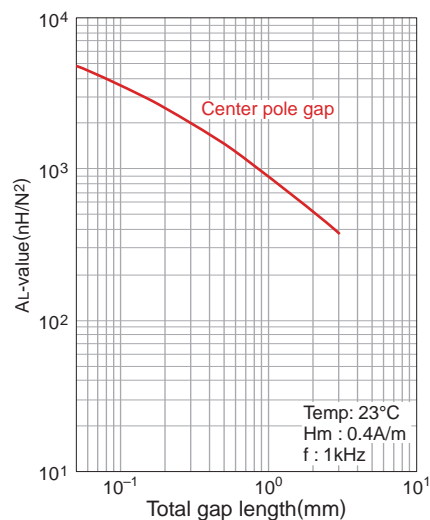

Mn-Zn EC series Part No.: PC40 EC90X90X30

SHAPES AND DIMENSIONS

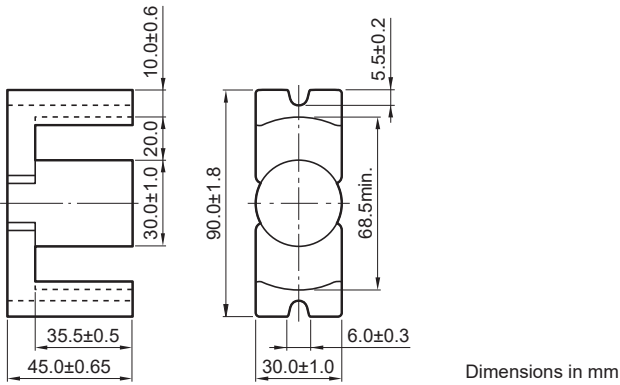

| Effective parameter | | | | | | | | | Electrical characteristics |
|------------------------------|---|---|---|--|---|---|--|------------------------|--|
| Core factor | | Effective magnetic path length l_e (mm) | Effective cross-sectional area A_e (mm ²) | Effective core volume V_e (mm ³) | Cross-sectional center pole area A_c (mm ²) | Minimum cross-sectional area A_{min}^* (mm ²) | Winding cross-sectional area A_{cw} (mm ²) | Weigh (approx.) (g) | AL-value (nH/N ²) 1kHz 0.4A/m 23°C |
| C_1 (mm ⁻¹) | $C_2 \times 10^{-2}$ (mm ⁻³) | | | | | | | | |
| 0.3533380 | 0.05648 | 221 | 626 | 138270 | 707 | 570B* | 1420 | 635 | 7415±25% |

* The symbol followed A min. value shows minimum cross-sectional area part.

C is center pole part, L is outer pole part, B is the back part.

○ Calculated output power (forward converter mode): 3.4kW (100kHz)

NI limit vs. AL-value

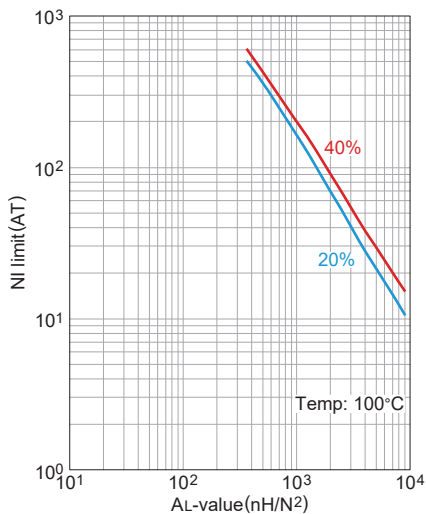

The 20% and 40% graph shows when a 20% and 40% drop from the initial AL-value has been made due to the DC superimposition.

AL-value vs. Air gap length

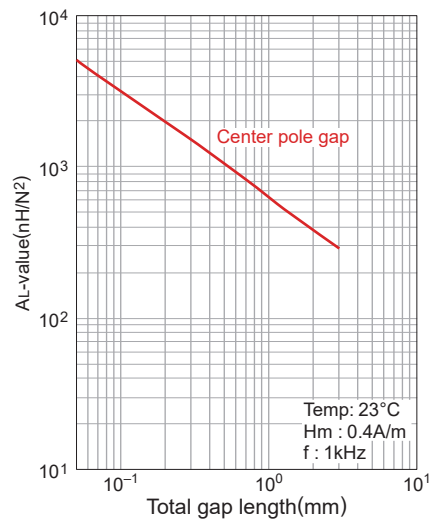

Mn-Zn EC series Part No.: PE22 EC120X101X30

SHAPES AND DIMENSIONS

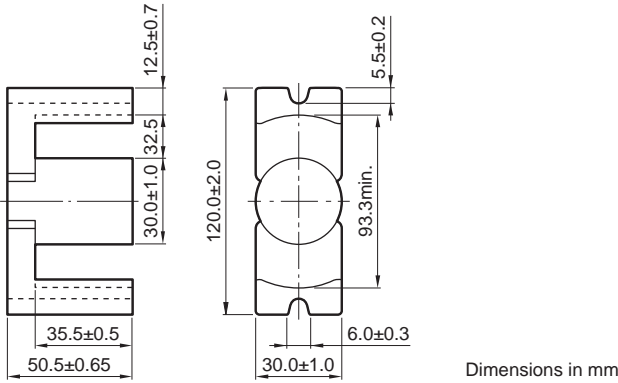

| Effective parameter | | | | | | | | | Electrical characteristics |
|------------------------------|---|---|---|--|---|--|--|------------------------|--|
| Core factor | | Effective magnetic path length l_e (mm) | Effective cross-sectional area A_e (mm ²) | Effective core volume V_e (mm ³) | Cross-sectional center pole area A_c (mm ²) | Minimum cross-sectional area $A_{min.}^*$ (mm ²) | Winding cross-sectional area A_{cw} (mm ²) | Weigh (approx.) (g) | AL-value (nH/N ²) 1kHz 0.4A/m 23°C |
| C_1 (mm ⁻¹) | $C_2 \times 10^{-2}$ (mm ⁻³) | | | | | | | | |
| 0.3300745 | 0.04278 | 255 | 773 | 196490 | 707 | 707C* | 2307 | 986 | 6395±25% |

* The symbol followed A min. value shows minimum cross-sectional area part.

C is center pole part, L is outer pole part, B is the back part.

○ Calculated output power (forward converter mode): 4.3kW (100kHz)

NI limit vs. AL-value

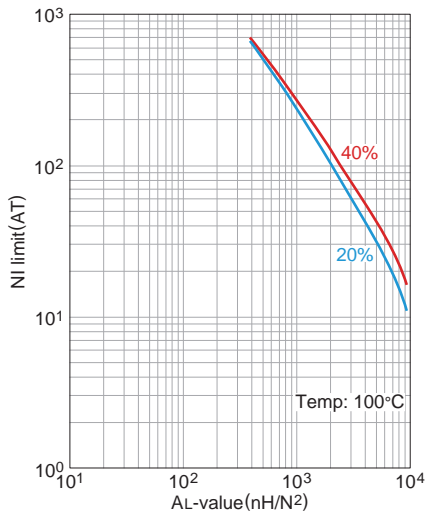

The 20% and 40% graph shows when a 20% and 40% drop from the initial AL-value has been made due to the DC superimposition.

AL-value vs. Air gap length

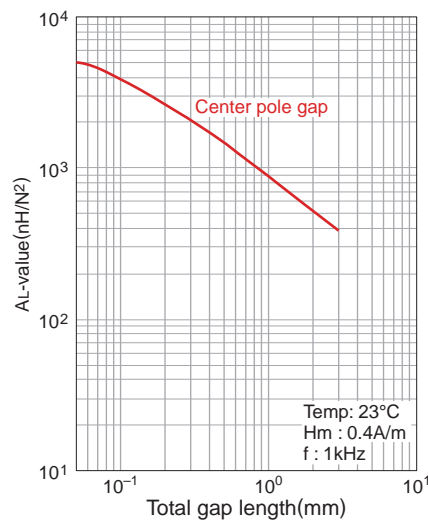

⚠ Please be sure to request delivery specifications that provide further details on the features and specifications of the products for proper and safe use. Please note that the contents may change without any prior notice due to reasons such as upgrading.

Mn-Zn EC series Part No.: PC40 EC120X101X30

SHAPES AND DIMENSIONS

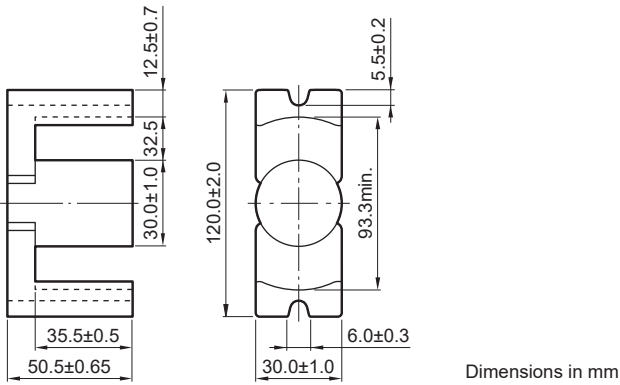

| Effective parameter | | | | | | | | | Electrical characteristics |
|------------------------------|---|---|---|--|---|--|--|------------------------|--|
| Core factor | | Effective magnetic path length l_e (mm) | Effective cross-sectional area A_e (mm ²) | Effective core volume V_e (mm ³) | Cross-sectional center pole area A_c (mm ²) | Minimum cross-sectional area $A_{min.}^*$ (mm ²) | Winding cross-sectional area A_{cw} (mm ²) | Weigh (approx.) (g) | AL-value (nH/N ²) 1kHz 0.4A/m 23°C |
| C_1 (mm ⁻¹) | $C_2 \times 10^{-2}$ (mm ⁻³) | | | | | | | | |
| 0.3300745 | 0.04278 | 255 | 773 | 196490 | 707 | 707C* | 2307 | 986 | 8025±25% |

* The symbol followed A min. value shows minimum cross-sectional area part.

C is center pole part, L is outer pole part, B is the back part.

○ Calculated output power (forward converter mode): 4.5kW (100kHz)

NI limit vs. AL-value

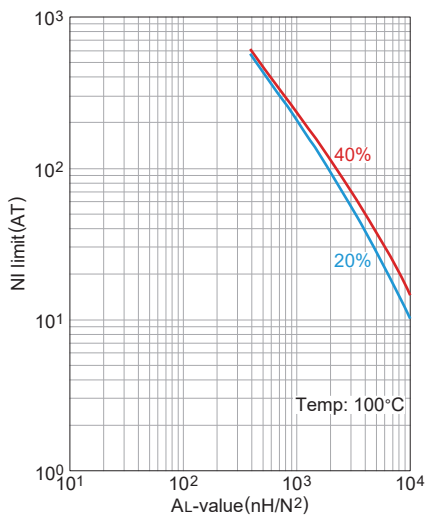

The 20% and 40% graph shows when a 20% and 40% drop from the initial AL-value has been made due to the DC superimposition.

AL-value vs. Air gap length

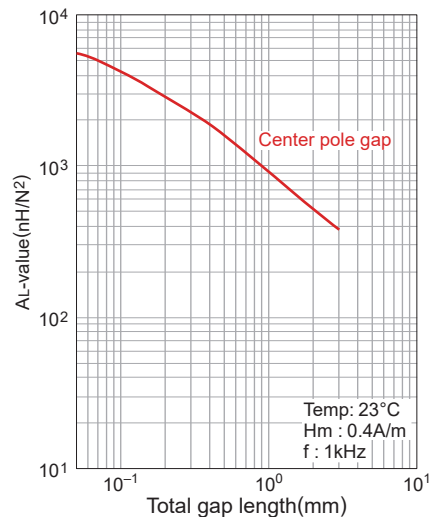

Mn-Zn EIC Cores



SHAPES AND DIMENSIONS

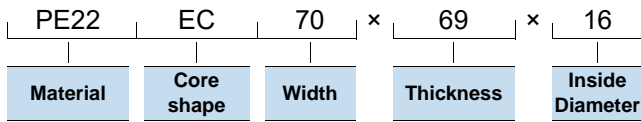
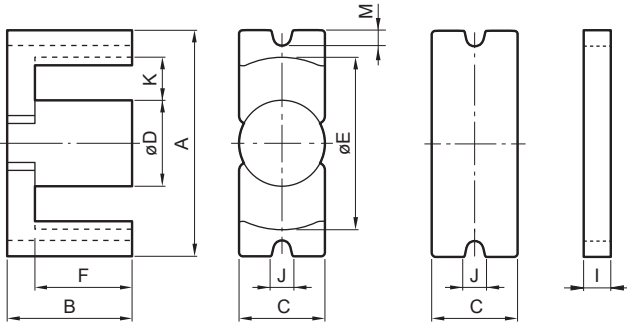

| Material | Part No. Shape Dimensions | Dimensions (mm) | | | | | | | | M | J | K |
|----------|------------------------------|-----------------|-----------|----------|----------|----------|-----------|-----------|-----|------|------|---|
| | | A | B+I | C | φD | φE | F | I | | | | |
| PE22 | EIC70x46X16 | 70.0±1.7 | 46.25±1.0 | 16.4±0.5 | 16.4±0.5 | 43.3min. | 22.75±0.5 | 11.75±0.5 | 5.2 | 4.75 | 14.1 | |
| PC40 | | | | | | | | | | | | |
| PC95 | | | | | | | | | | | | |
| PEL95 | | | | | | | | | | | | |
| PEM95 | | | | | | | | | | | | |
| PE22 | EIC90x55X30 | 90.0±1.8 | 55.0±1.0 | 30.0±1.0 | 30.0±1.0 | 68.5min. | 35.5±0.5 | 10.0±0.35 | 5.5 | 6.00 | 20.0 | |
| PC40 | | | | | | | | | | | | |
| PC95 | | | | | | | | | | | | |
| PEL95 | | | | | | | | | | | | |
| PEM95 | | | | | | | | | | | | |
| PE22 | EIC120x65X30 | 120.0±2.0 | 65.5±1.3 | 30.0±1.0 | 30.0±1.0 | 93.3min. | 25.5±0.5 | 15.0±0.65 | 5.5 | 6.00 | 32.5 | |
| PC40 | | | | | | | | | | | | |
| PC95 | | | | | | | | | | | | |
| PEL95 | | | | | | | | | | | | |
| PEM95 | | | | | | | | | | | | |

⚠ Please be sure to request delivery specifications that provide further details on the features and specifications of the products for proper and safe use.
Please note that the contents may change without any prior notice due to reasons such as upgrading.

Mn-Zn EIC Cores

| Material | Part No. | | Effective parameter | | | | Electrical characteristics AL-value (nH/N ²) 1kHz, 0.4A/m 23 °C | |
|----------|---------------------|-------------|--|--|---|------------------------|---|---------------------------------------|
| | Shape Dimensions | Core factor | Effective cross-sectional area Ae (mm ²) | Effective magnetic path length Le (mm) | Effective core volume Ve (mm ³) | Weigh (Approx.) (g) | | |
| | | | | | | | | C ₁ (mm ⁻¹) |
| PE22 | EIC70x46X16 | 0.3479 | 0.1173 | 297 | 103 | 30601 | 188 | 5550±25% |
| PC40 | | | | | | | | 6810±25% |
| PC95 | | | | | | | | — |
| PEL95 | | | | | | | | — |
| PEM95 | | | | | | | | — |
| PE22 | EIC90x55X30 | 0.2422 | 0.0388 | 624 | 151 | 94432 | 469 | 8350±25% |
| PC40 | | | | | | | | 10365±25% |
| PC95 | | | | | | | | — |
| PEL95 | | | | | | | | — |
| PEM95 | | | | | | | | — |
| PE22 | EIC120x65X30 | 0.2319 | 0.0292 | 794 | 184 | 146310 | 747 | 8890±25% |
| PC40 | | | | | | | | 11085±25% |
| PC95 | | | | | | | | — |
| PEL95 | | | | | | | | — |
| PEM95 | | | | | | | | — |

⚠ Please be sure to request delivery specifications that provide further details on the features and specifications of the products for proper and safe use.
Please note that the contents may change without any prior notice due to reasons such as upgrading.

Mn-Zn EIC series Part No.: PE22 EIC90X55X30

SHAPES AND DIMENSIONS

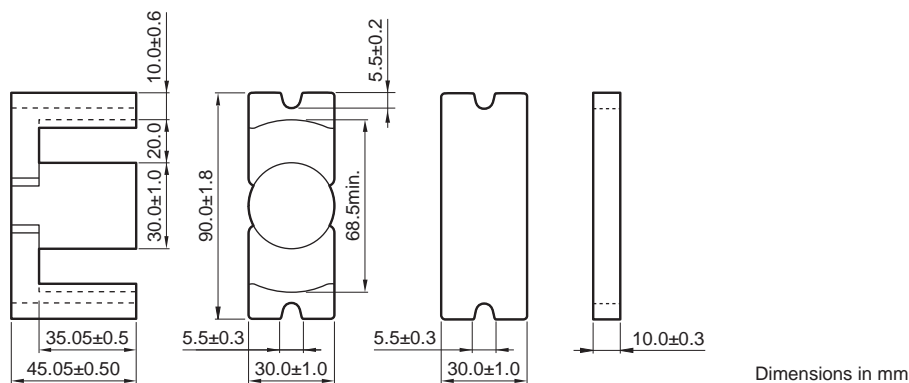

| Effective parameter | | | | | | | | | Electrical characteristics |
|------------------------------|---|---|---|--|---|--|--|------------------------|--|
| Core factor | | Effective magnetic path length l_e (mm) | Effective cross-sectional area A_e (mm ²) | Effective core volume V_e (mm ³) | Cross-sectional center pole area A_c (mm ²) | Minimum cross-sectional area $A_{min.}^*$ (mm ²) | Winding cross-sectional area A_{cw} (mm ²) | Weigh (approx.) (g) | AL-value (nH/N ²) 1kHz 0.4A/m 23°C |
| C_1 (mm ⁻¹) | $C_2 \times 10^{-2}$ (mm ⁻³) | | | | | | | | |
| 0.2422 | 0.0388 | 151 | 624 | 94432 | 707 | 586B* | 710 | 469 | 8350±25% |

* The symbol followed A min. value shows minimum cross-sectional area part.

C is center pole part, L is outer pole part, B is the back part.

○ Calculated output power (forward converter mode): 1.8kW (100kHz)

Mn-Zn EIC series Part No.: PC40 EIC90X55X30

SHAPES AND DIMENSIONS

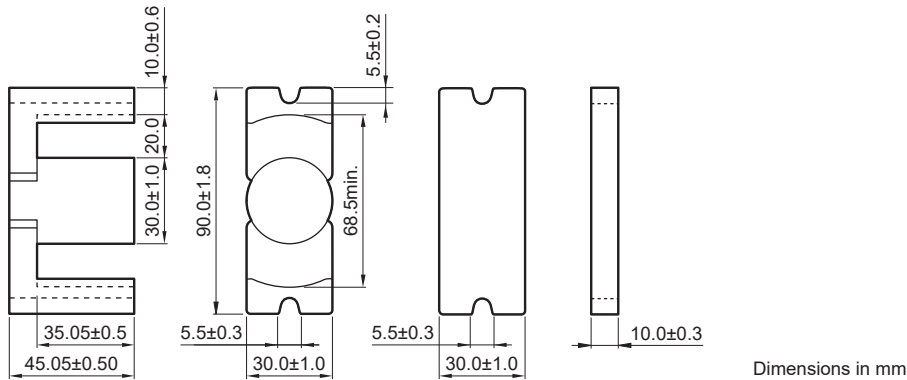

| Effective parameter | | | | | | | | | Electrical characteristics |
|------------------------------|---|---|---|--|---|--|--|------------------------|--|
| Core factor | | Effective magnetic path length l_e (mm) | Effective cross-sectional area A_e (mm ²) | Effective core volume V_e (mm ³) | Cross-sectional center pole area A_c (mm ²) | Minimum cross-sectional area $A_{min.}^*$ (mm ²) | Winding cross-sectional area A_{cw} (mm ²) | Weigh (approx.) (g) | AL-value (nH/N ²) 1kHz 0.4A/m 23°C |
| C_1 (mm ⁻¹) | $C_2 \times 10^{-2}$ (mm ⁻³) | | | | | | | | |
| 0.2422 | 0.0388 | 151 | 624 | 94432 | 707 | 586B* | 710 | 469 | 10365±25% |

* The symbol followed A min. value shows minimum cross-sectional area part.

C is center pole part, L is outer pole part, B is the back part.

○ Calculated output power (forward converter mode): 1.9kW (100kHz)

Mn-Zn EIC series **Part No.: PE22 EIC120X65X30**

■ SHAPES AND DIMENSIONS

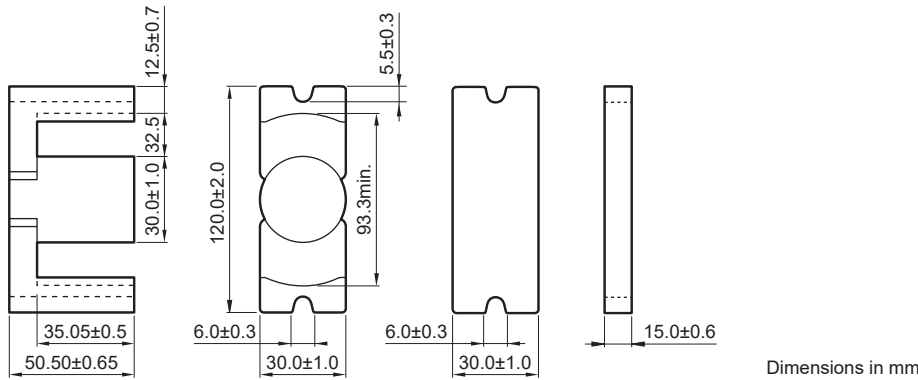

| Effective parameter | | | | | | | | | Electrical characteristics |
|------------------------------|---|---|---|--|---|--|--|------------------------|--|
| Core factor | | Effective magnetic path length l_e (mm) | Effective cross-sectional area A_e (mm ²) | Effective core volume V_e (mm ³) | Cross-sectional center pole area A_c (mm ²) | Minimum cross-sectional area $A_{min.}^*$ (mm ²) | Winding cross-sectional area A_{cw} (mm ²) | Weigh (approx.) (g) | AL-value (nH/N ²) 1kHz 0.4A/m 23°C |
| C_1 (mm ⁻¹) | $C_2 \times 10^{-2}$ (mm ⁻³) | | | | | | | | |
| 0.2319 | 0.0292 | 184 | 794 | 146310 | 707 | 707C* | 1154 | 747 | 8890±25% |

* The symbol followed A min. value shows minimum cross-sectional area part.

C is center pole part, L is outer pole part, B is the back part.

• Available customize core like this. Please specify when ordering.

○ Calculated output power (forward converter mode): 2.8kW (100kHz)

Mn-Zn EIC series **Part No.: PC40 EIC120X65X30**

■ SHAPES AND DIMENSIONS

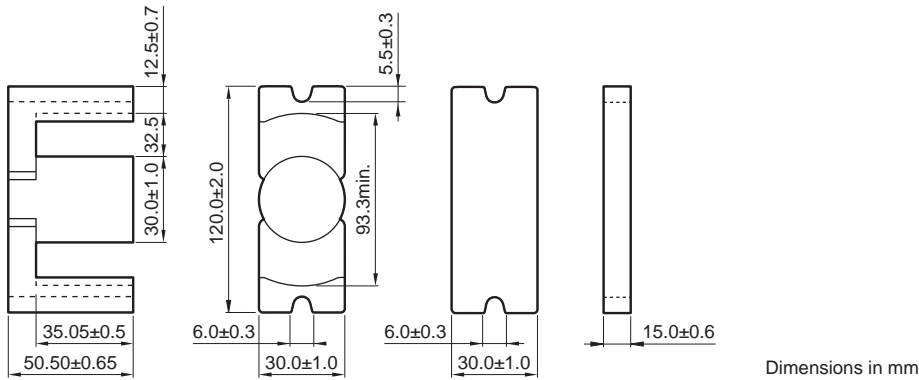

| Effective parameter | | | | | | | | | Electrical characteristics |
|------------------------------|---|---|---|--|---|--|--|------------------------|--|
| Core factor | | Effective magnetic path length l_e (mm) | Effective cross-sectional area A_e (mm ²) | Effective core volume V_e (mm ³) | Cross-sectional center pole area A_c (mm ²) | Minimum cross-sectional area $A_{min.}^*$ (mm ²) | Winding cross-sectional area A_{cw} (mm ²) | Weigh (approx.) (g) | AL-value (nH/N ²) 1kHz 0.4A/m 23°C |
| C_1 (mm ⁻¹) | $C_2 \times 10^{-2}$ (mm ⁻³) | | | | | | | | |
| 0.2319 | 0.0292 | 184 | 794 | 146310 | 707 | 707C* | 1154 | 747 | 11085±25% |

- * The symbol followed A min. value shows minimum cross-sectional area part.
C is center pole part, L is outer pole part, B is the back part.
- Available customize core like this. Please specify when ordering.
- Calculated output power (forward converter mode): 2.9kW (100kHz)

Mn-Zn EE Cores



SHAPES AND DIMENSIONS

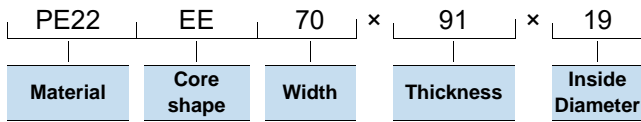
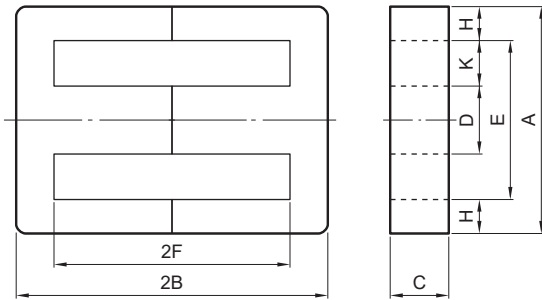

| Material | Part No. Shape Dimensions | Dimensions (mm) | | | | | | | | | Kx2F(mm ²) |
|----------|------------------------------|-----------------|-----------|----------|----------|----------|----------|----------|---------|------|------------------------|
| | | A | 2B | C | D | E | 2F | H | R | K | |
| PE22 | EE70x91x19 | 70.0±1.5 | 91.0±1.0 | 19.5±0.5 | 19.5±0.5 | 48.5min. | 71.0±1.0 | 10.0±0.5 | 0 | 15.3 | 1086 |
| PC40 | | | | | | | | | | | |
| PC95 | | | | | | | | | | | |
| PEL95 | | | | | | | | | | | |
| PEM95 | | | | | | | | | | | |
| PE22 | EE80x76x20 | 80.0±1.5 | 76.0±1.0 | 20.0±0.5 | 20.0±0.5 | 58.5min. | 55.0±0.8 | 10.0±0.5 | 0.5max. | 20.0 | 1100 |
| PC40 | | | | | | | | | | | |
| PC95 | | | | | | | | | | | |
| PEL95 | | | | | | | | | | | |
| PEM95 | | | | | | | | | | | |
| PE22 | EE90X56X16 | 90.0±2.0 | 56.4±1.0 | 16.5±0.5 | 25.0±1.0 | 63.0min. | 30.4±1.0 | 12.5±0.5 | 0.5max. | 20.0 | 608 |
| PC40 | | | | | | | | | | | |
| PC95 | | | | | | | | | | | |
| PEL95 | | | | | | | | | | | |
| PEM95 | | | | | | | | | | | |
| PE22 | EE70X108X31N | 70.0±1.5 | 108.0±1.0 | 31.6±0.5 | 22.2±0.5 | 46.3min. | 85.6±1.0 | 11.1±0.5 | 2.0max | 12.8 | 1096 |
| PC40 | | | | | | | | | | | |
| PC95 | | | | | | | | | | | |
| PEL95 | | | | | | | | | | | |
| PEM95 | | | | | | | | | | | |

⚠ Please be sure to request delivery specifications that provide further details on the features and specifications of the products for proper and safe use.
Please note that the contents may change without any prior notice due to reasons such as upgrading.

Mn-Zn EE Cores

| Material | Part No. Shape Dimensions | Effective parameter | | Effective cross-sectional area Ae (mm ²) | Effective magnetic path length Le (mm) | Effective core volume Ve (mm ³) | Weigh (Approx.) (g) | Electrical characteristics AL-value (nH/N ²) 1kHz, 0.4A/m 23 °C |
|----------|------------------------------|---------------------------------------|---|---|---|--|------------------------|---|
| | | Core factor C1 (mm ⁻¹) | C2 x 10 ⁻² (mm ⁻³) | | | | | |
| PE22 | EE70x91x19 | 0.52779 | 0.13669 | 386 | 204 | 78690 | 394 | 3930±25% |
| PC40 | | | | | | | | 4910±25% |
| PC95 | | | | | | | | — |
| PEL95 | | | | | | | | — |
| PEM95 | | | | | | | | — |
| PE22 | EE80x76x20 | 0.44878 | 0.11058 | 406 | 182 | 73910 | 372 | 4590±25% |
| PC40 | | | | | | | | 5720±25% |
| PC95 | | | | | | | | 7260±25% |
| PEL95 | | | | | | | | 9360 * |
| PEM95 | | | | | | | | 6850 * |
| PE22 | EE90X56X16 | 0.33583 | 0.08009 | 419 | 141 | 59050 | 306 | 5960±25% |
| PC40 | | | | | | | | 7380±25% |
| PC95 | | | | | | | | — |
| PEL95 | | | | | | | | — |
| PEM95 | | | | | | | | — |
| PE22 | EE70X108X31N | 0.32992 | 0.04695 | 703 | 232 | 162900 | 815 | 6360±25% |
| PC40 | | | | | | | | 7970±25% |
| PC95 | | | | | | | | — |
| PEL95 | | | | | | | | — |
| PEM95 | | | | | | | | — |

* Typ. value for no specification tolerance

□ Core loss Temperature characteristics (Typ.)
EE80x76x20 at 25kHz,200mT

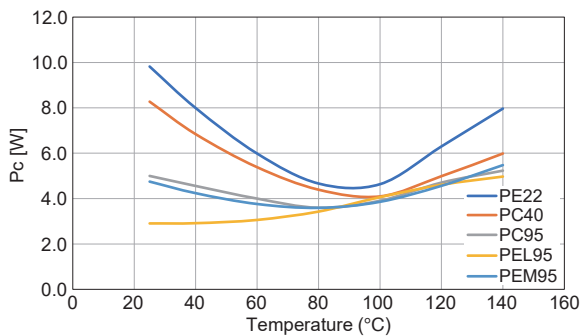

⚠ Please be sure to request delivery specifications that provide further details on the features and specifications of the products for proper and safe use.
Please note that the contents may change without any prior notice due to reasons such as upgrading.

Mn-Zn EE series Part No.: PE22 EE70X91X19

SHAPES AND DIMENSIONS

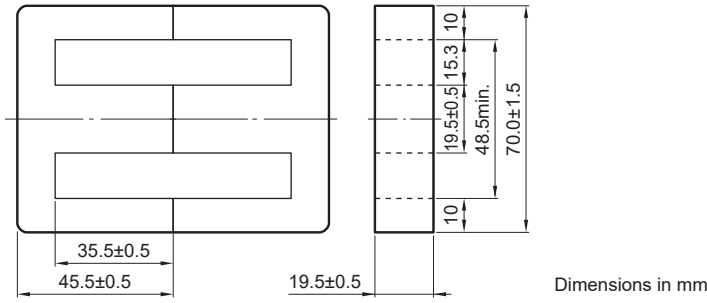

| Effective parameter | | | | | | | | | Electrical characteristics |
|------------------------------|---|---|---|--|---|---|---|------------------------|--|
| Core factor | | Effective magnetic path length l_e (mm) | Effective cross-sectional area A_e (mm ²) | Effective core volume V_e (mm ³) | Cross-sectional center pole area A_c (mm ²) | Minimum cross-sectional area $A_{\text{min.}}$ (mm ²) | Winding cross-sectional area A_{cw} (mm ²) | Weigh (approx.) (g) | AL-value (nH/N ²) 1kHz 0.4A/m 23°C |
| C_1 (mm ⁻¹) | $C_2 \times 10^{-2}$ (mm ⁻³) | | | | | | | | |
| 0.5278 | 0.1367 | 204 | 386 | 78690 | 380 | 380C* | 1086 | 394 | 3930±25% |

* The symbol followed A min. value shows minimum cross-sectional area part.

C is center pole part, L is outer pole part, B is the back part.

○ Calculated output power (forward converter mode): 1.4kW (100kHz)

NI limit vs. AL-value

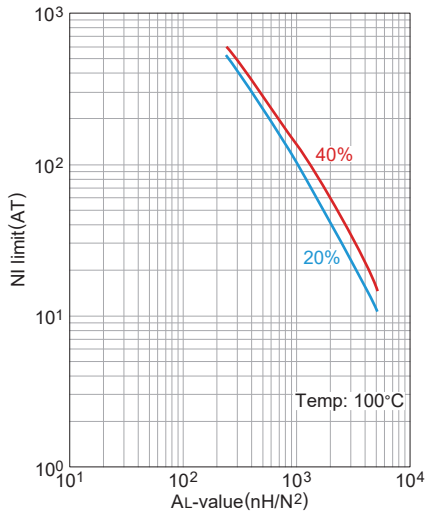

The 20% and 40% graph shows when a 20% and 40% drop from the initial AL-value has been made due to the DC superimposition.

AL-value vs. Air gap length

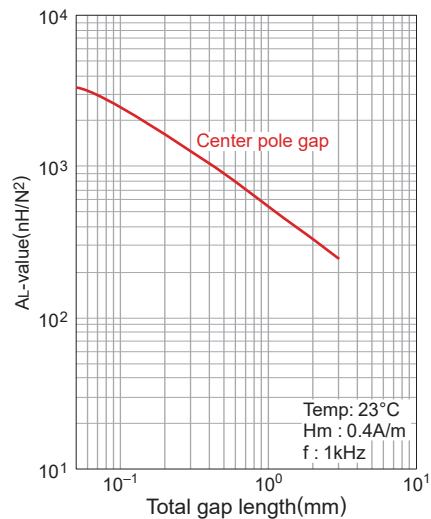

Mn-Zn EE series Part No.: PC40 EE70X91X19

SHAPES AND DIMENSIONS

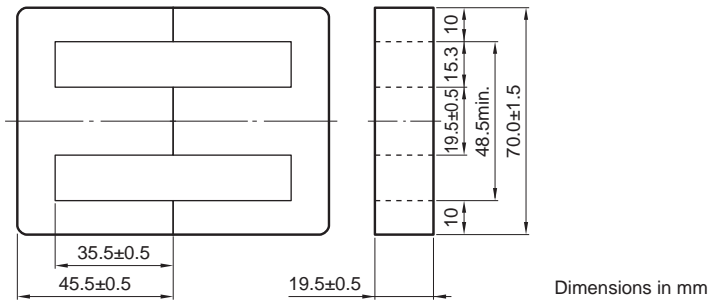

| Effective parameter | | | | | | | | | Electrical characteristics |
|------------------------------|---|---|---|--|---|---|--|------------------------|--|
| Core factor | | Effective magnetic path length l_e (mm) | Effective cross-sectional area A_e (mm ²) | Effective core volume V_e (mm ³) | Cross-sectional center pole area A_c (mm ²) | Minimum cross-sectional area A_{min}^* (mm ²) | Winding cross-sectional area A_{cw} (mm ²) | Weigh (approx.) (g) | AL-value (nH/N ²) 1kHz 0.4A/m 23°C |
| C_1 (mm ⁻¹) | $C_2 \times 10^{-2}$ (mm ⁻³) | | | | | | | | |
| 0.5278 | 0.1367 | 204 | 386 | 78690 | 380 | 380C* | 1086 | 394 | 4910±25% |

* The symbol followed A min. value shows minimum cross-sectional area part.

C is center pole part, L is outer pole part, B is the back part.

○ Calculated output power (forward converter mode): 1.6kW (100kHz)

NI limit vs. AL-value

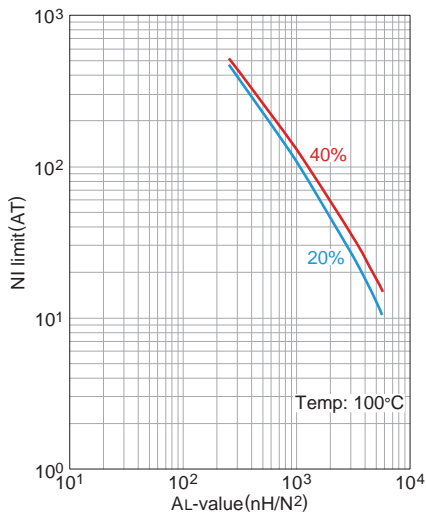

The 20% and 40% graph shows when a 20% and 40% drop from the initial AL-value has been made due to the DC superimposition.

AL-value vs. Air gap length

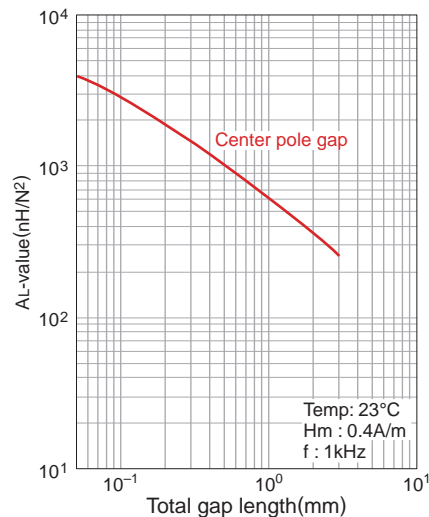

Mn-Zn EE series Part No.: PE22 EE80X76X20

SHAPES AND DIMENSIONS

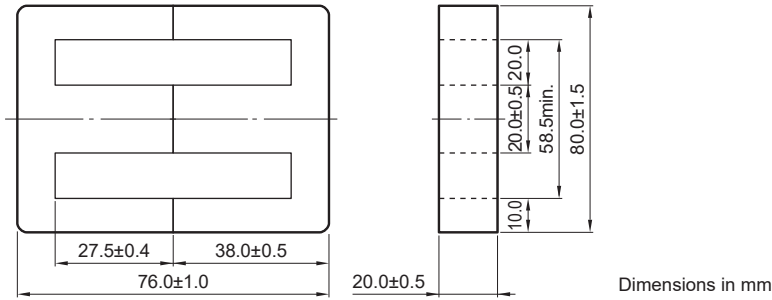

| Effective parameter | | | | | | | | | Electrical characteristics |
|------------------------------|---|---|---|--|---|--|--|------------------------|--|
| Core factor | | Effective magnetic path length l_e (mm) | Effective cross-sectional area A_e (mm ²) | Effective core volume V_e (mm ³) | Cross-sectional center pole area A_c (mm ²) | Minimum cross-sectional area $A_{min.}^*$ (mm ²) | Winding cross-sectional area A_{cw} (mm ²) | Weigh (approx.) (g) | AL-value (nH/N ²) 1kHz 0.4A/m 23°C |
| C_1 (mm ⁻¹) | $C_2 \times 10^{-2}$ (mm ⁻³) | | | | | | | | |
| 0.44878 | 0.1106 | 182 | 406 | 73910 | 400 | 400LC* | 1100 | 372 | 4590±25% |

* The symbol followed A min. value shows minimum cross-sectional area part.

C is center pole part, L is outer pole part, B is the back part.

○ Calculated output power (forward converter mode): 1.4kW (100kHz)

NI limit vs. AL-value

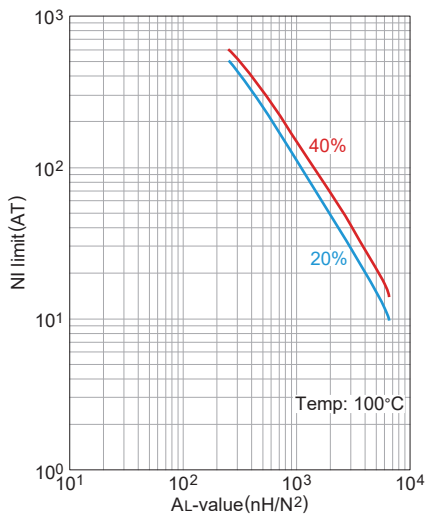

The 20% and 40% graph shows when a 20% and 40% drop from the initial AL-value has been made due to the DC superimposition.

AL-value vs. Air gap length

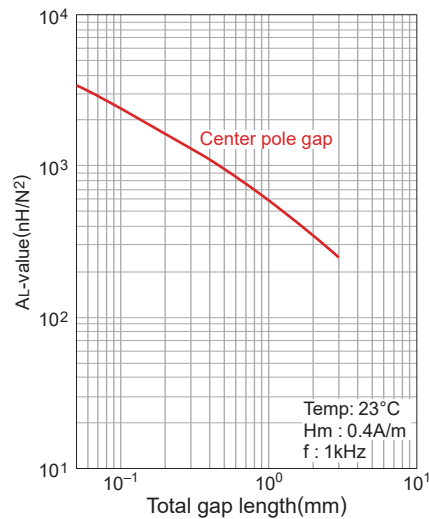

Mn-Zn EE series Part No.: PC40 EE80X76X20

SHAPES AND DIMENSIONS

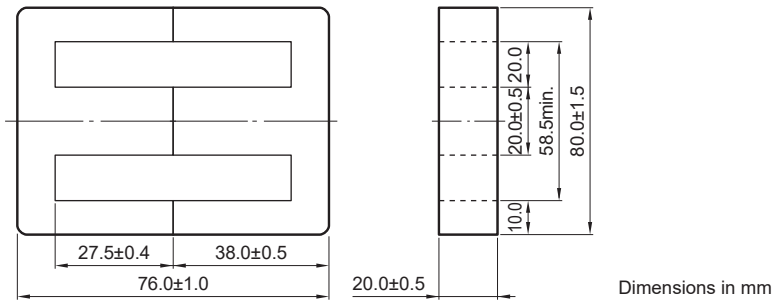

| Effective parameter | | | | | | | | | Electrical characteristics |
|---------------------------------------|---|--------------------------------|--------------------------------------|--------------------------------------|--------------------------------------|-------------------------------|---------------------------------------|-----------------|--|
| Core factor | | Effective magnetic path length | Effective cross-sectional area | Effective core volume | Cross-sectional center pole area | Minimum cross-sectional area | Winding cross-sectional area | Weigh (approx.) | AL-value |
| C ₁ (mm ⁻¹) | C ₂ ×10 ⁻² (mm ⁻³) | l _e (mm) | A _e (mm ²) | V _e (mm ³) | A _c (mm ²) | A min.* (mm ²) | A _{cw} (mm ²) | (g) | (nH/N ²) 1kHz 0.4A/m 23°C |
| 0.44878 | 0.1106 | 182 | 406 | 73910 | 400 | 400LC* | 1100 | 372 | 5720±25% |

* The symbol followed A min. value shows minimum cross-sectional area part.

C is center pole part, L is outer pole part, B is the back part.

○ Calculated output power (forward converter mode): 1.5kW (100kHz)

NI limit vs. AL-value

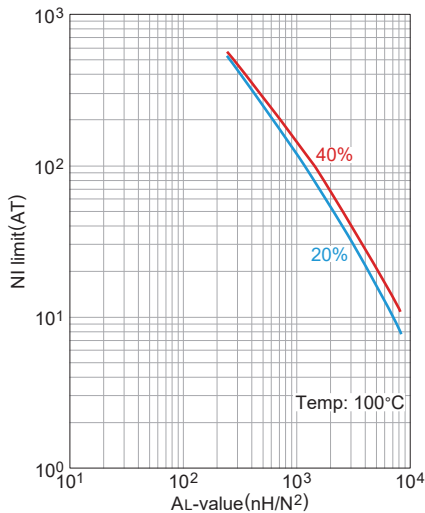

The 20% and 40% graph shows when a 20% and 40% drop from the initial AL-value has been made due to the DC superimposition.

AL-value vs. Air gap length

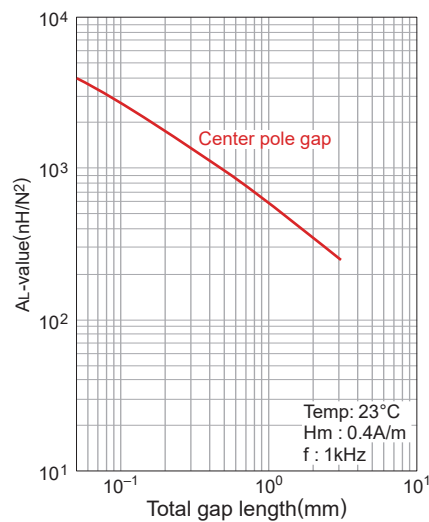

Mn-Zn EE series Part No.: PE22 EE90X56X16

SHAPES AND DIMENSIONS

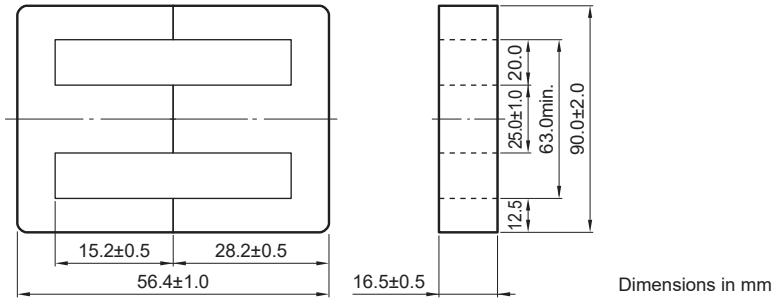

| Effective parameter | | | | | | | | | Electrical characteristics |
|---------------------------------------|---|--------------------------------|--------------------------------------|--------------------------------------|--------------------------------------|-------------------------------|---------------------------------------|-----------------|--|
| Core factor | | Effective magnetic path length | Effective cross-sectional area | Effective core volume | Cross-sectional center pole area | Minimum cross-sectional area | Winding cross-sectional area | Weigh (approx.) | AL-value |
| C ₁ (mm ⁻¹) | C ₂ ×10 ⁻² (mm ⁻³) | l _e (mm) | A _e (mm ²) | V _e (mm ³) | A _c (mm ²) | A min.* (mm ²) | A _{cw} (mm ²) | (g) | (nH/N ²) 1kHz 0.4A/m 23°C |
| 0.33583 | 0.0801 | 144 | 419 | 59050 | 413 | 413LC* | 608 | 306 | 5960±25% |

* The symbol followed A min. value shows minimum cross-sectional area part.

C is center pole part, L is outer pole part, B is the back part.

○ Calculated output power (forward converter mode): 1.2kW (100kHz)

NI limit vs. AL-value

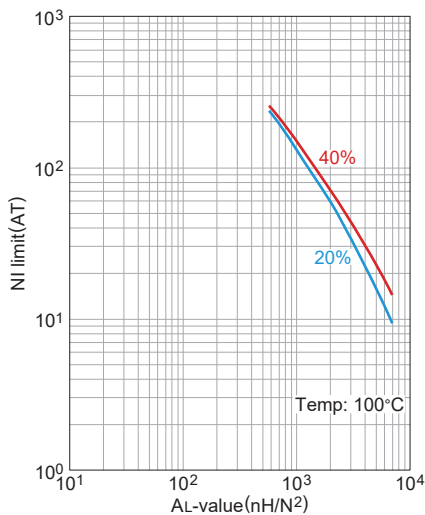

The 20% and 40% graph shows when a 20% and 40% drop from the initial AL-value has been made due to the DC superimposition.

AL-value vs. Air gap length

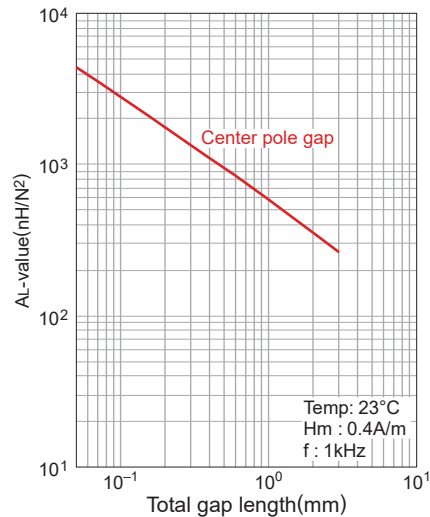

Mn-Zn EE series Part No.: PC40 EE90X56X16

SHAPES AND DIMENSIONS

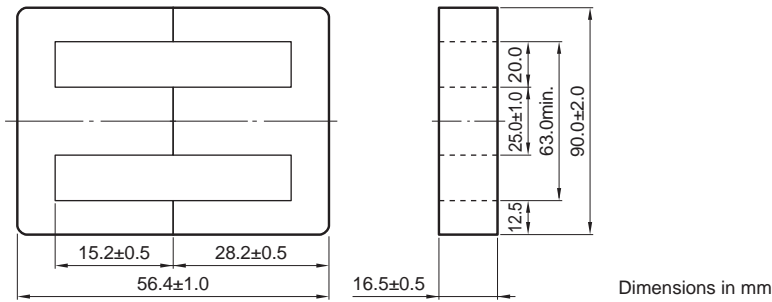

| Effective parameter | | | | | | | | | Electrical characteristics |
|---------------------------------------|---|--------------------------------|--------------------------------------|--------------------------------------|--------------------------------------|-------------------------------|---------------------------------------|-----------------|--|
| Core factor | | Effective magnetic path length | Effective cross-sectional area | Effective core volume | Cross-sectional center pole area | Minimum cross-sectional area | Winding cross-sectional area | Weigh (approx.) | AL-value |
| C ₁ (mm ⁻¹) | C ₂ ×10 ⁻² (mm ⁻³) | ℓ _e (mm) | A _e (mm ²) | V _e (mm ³) | A _c (mm ²) | A min.* (mm ²) | A _{cw} (mm ²) | (g) | (nH/N ²) 1kHz 0.4A/m 23°C |
| 0.33583 | 0.0801 | 141 | 419 | 59050 | 413 | 413LC* | 608 | 306 | 7380±25% |

* The symbol followed A min. value shows minimum cross-sectional area part.

C is center pole part, L is outer pole part, B is the back part.

○ Calculated output power (forward converter mode): 1.3kW (100kHz)

NI limit vs. AL-value

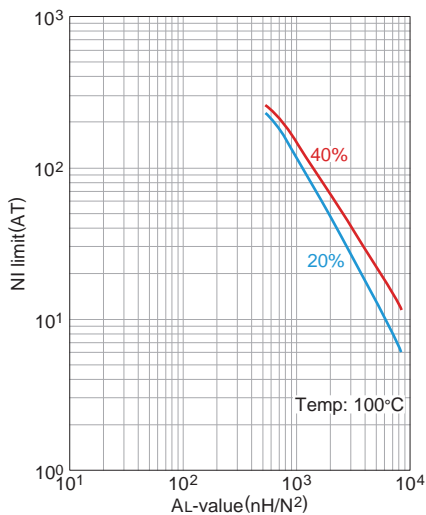

The 20% and 40% graph shows when a 20% and 40% drop from the initial AL-value has been made due to the DC superimposition.

AL-value vs. Air gap length

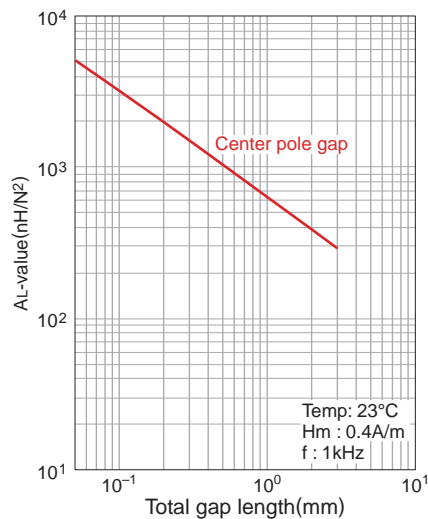

Mn-Zn EI Cores



SHAPES AND DIMENSIONS

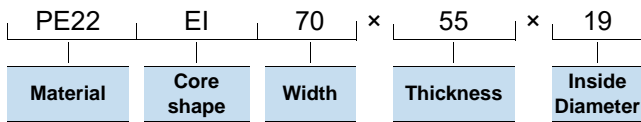
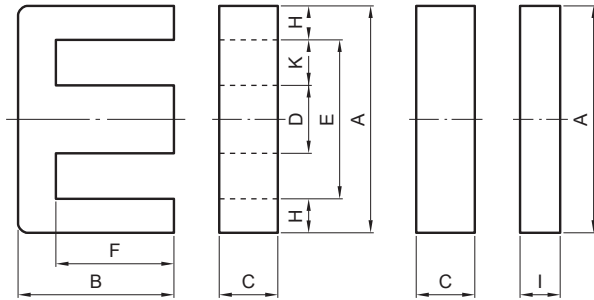

| Material | Part No. Shape Dimensions | Dimensions (mm) | | | | | | | | | | |
|----------|------------------------------|-----------------|----------|----------|----------|----------|----------|----------|----------|---------|------|------------------------|
| | | A | B+I | C | D | E | F | H | I | R | K | Kx2F(mm ²) |
| PE22 | EI70x55x19 | 70.0±1.5 | 55.5±1.0 | 19.5±0.5 | 19.5±0.5 | 48.5min. | 35.0±0.5 | 10.0±0.5 | 10.5±0.5 | 0.5max. | 15.3 | 536 |
| PC40 | | | | | | | | | | | | |
| PC95 | | | | | | | | | | | | |
| PEL95 | | | | | | | | | | | | |
| PEM95 | | | | | | | | | | | | |
| PE22 | EI70x64x31N | 70.0±1.5 | 64.4±1.0 | 31.6±0.5 | 22.2±0.5 | 46.3min. | 42.8±0.5 | 11.1±0.5 | 10.4±0.5 | 2.0max. | 12.8 | 548 |
| PC40 | | | | | | | | | | | | |
| PC95 | | | | | | | | | | | | |
| PEL95 | | | | | | | | | | | | |
| PEM95 | | | | | | | | | | | | |

⚠ Please be sure to request delivery specifications that provide further details on the features and specifications of the products for proper and safe use.
Please note that the contents may change without any prior notice due to reasons such as upgrading.

Mn-Zn EI Cores

| Material | Part No. Shape Dimensions | Effective parameter Core factor | | Effective cross-sectional area Ae (mm ²) | Effective magnetic path length Le (mm) | Effective core volume Ve (mm ³) | Weigh (Approx.) (g) | Electrical characteristics AL-value (nH/N ²) 1kHz, 0.4A/m 23 °C |
|----------|---------------------------------|---------------------------------------|--|--|--|--|---------------------------|--|
| | | C ₁ (mm ⁻¹) | C ₂ x 10 ⁻² (mm ⁻³) | | | | | |
| PE22 | EI70x55x19 | 0.33894 | 0.08693 | 390 | 132 | 51520 | 266 | 5880±25% |
| PC40 | | | | | | | | 7270±25% |
| PC95 | | | | | | | | — |
| PEL95 | | | | | | | | — |
| PEM95 | | | | | | | | — |
| PE22 | EI70x64x31N | 0.20929 | 0.0301 | 695 | 146 | 101200 | 519 | 9585±25% |
| PC40 | | | | | | | | 11885±25% |
| PC95 | | | | | | | | — |
| PEL95 | | | | | | | | — |
| PEM95 | | | | | | | | — |

Please be sure to request delivery specifications that provide further details on the features and specifications of the products for proper and safe use.
Please note that the contents may change without any prior notice due to reasons such as upgrading.

Mn-Zn EI series Part No.: PE22 EI70X55X19

SHAPES AND DIMENSIONS

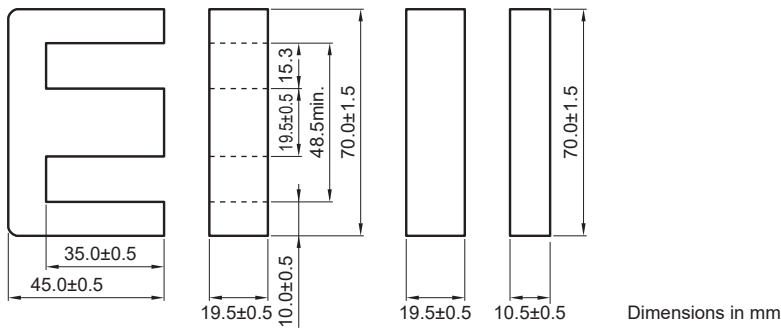

| Effective parameter | | | | | | | | | Electrical characteristics |
|------------------------------|---|---|---|--|---|--|--|------------------------|--|
| Core factor | | Effective magnetic path length l_e (mm) | Effective cross-sectional area A_e (mm ²) | Effective core volume V_e (mm ³) | Cross-sectional center pole area A_c (mm ²) | Minimum cross-sectional area $A_{min.}^*$ (mm ²) | Winding cross-sectional area A_{cw} (mm ²) | Weigh (approx.) (g) | AL-value (nH/N ²) 1kHz 0.4A/m 23°C |
| C_1 (mm ⁻¹) | $C_2 \times 10^{-2}$ (mm ⁻³) | | | | | | | | |
| 0.33894 | 0.08693 | 132 | 390 | 51520 | 380 | 380C* | 543 | 266 | 5880±25% |

* The symbol followed A min. value shows minimum cross-sectional area part.

C is center pole part, L is outer pole part, B is the back part.

○ Calculated output power (forward converter mode): 1.4kW (100kHz)

NI limit vs. AL-value

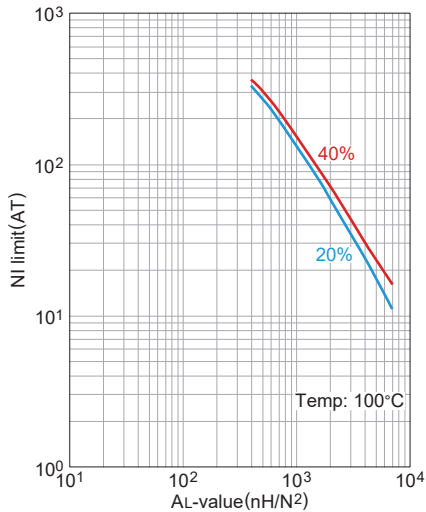

The 20% and 40% graph shows when a 20% and 40% drop from the initial AL-value has been made due to the DC superimposition.

AL-value vs. Air gap length

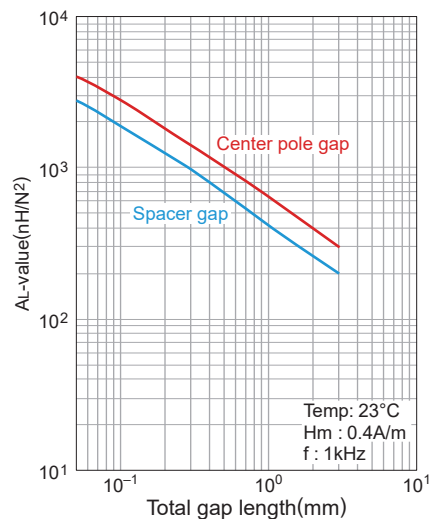

Mn-Zn EI series Part No.: PC40 EI70X55X19

SHAPES AND DIMENSIONS

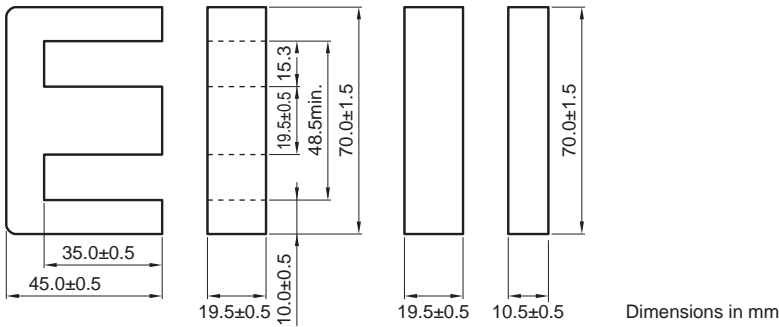

| Effective parameter | | | | | | | | | Electrical characteristics |
|------------------------------|---|---|---|--|---|--|--|------------------------|--|
| Core factor | | Effective magnetic path length l_e (mm) | Effective cross-sectional area A_e (mm ²) | Effective core volume V_e (mm ³) | Cross-sectional center pole area A_c (mm ²) | Minimum cross-sectional area $A_{min.}^*$ (mm ²) | Winding cross-sectional area A_{cw} (mm ²) | Weigh (approx.) (g) | AL-value (nH/N ²) 1kHz 0.4A/m 23°C |
| C_1 (mm ⁻¹) | $C_2 \times 10^{-2}$ (mm ⁻³) | | | | | | | | |
| 0.33894 | 0.08693 | 132 | 390 | 51520 | 380 | 380C* | 543 | 266 | 7270±25% |

* The symbol followed A min. value shows minimum cross-sectional area part.

C is center pole part, L is outer pole part, B is the back part.

○ Calculated output power (forward converter mode): 1.6kW (100kHz)

NI limit vs. AL-value

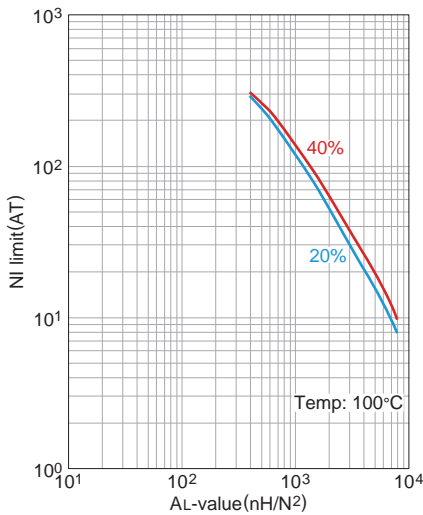

The 20% and 40% graph shows when a 20% and 40% drop from the initial AL-value has been made due to the DC superimposition.

AL-value vs. Air gap length

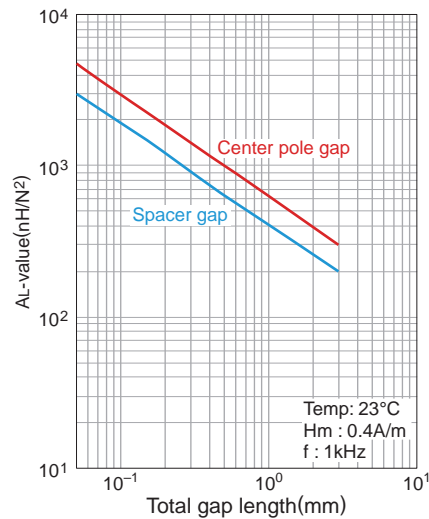

Mn-Zn ETD Cores



SHAPES AND DIMENSIONS

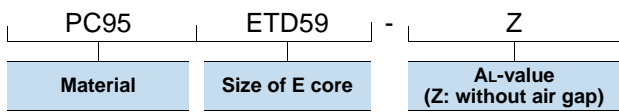
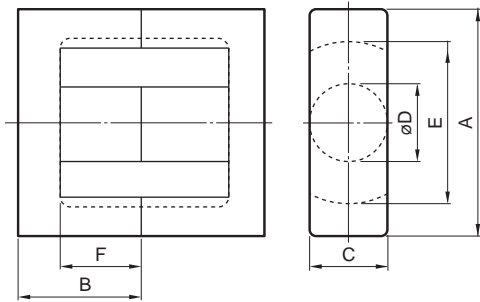

| Material | Part No. Shape Dimensions | Dimensions (mm) | | | | | |
|----------|------------------------------|-----------------|------------|------------|------------|------------|------------|
| | | A | B | C | φD | E | F |
| PC95 | ETD59-Z | 59.80±1.4 | 31.00±0.20 | 21.65±0.45 | 21.65±0.45 | 44.70±1.20 | 22.45±0.45 |
| PEL95 | | | | | | | |
| PEM95 | | | | | | | |

| Material | Part No. Shape Dimensions | Effective parameter | | | | | Electrical characteristics AL-value (nH/N ²) 1kHz, 0.5A/m 100Ts |
|----------|------------------------------|--|--|--|---|------------------------|---|
| | | Core factor C ₁ (mm ⁻¹) | Effective cross-sectional area A _e (mm ²) | Effective magnetic path length L _e (mm) | Effective core volume V _e (mm ³) | Weigh (Approx.) (g) | |
| PC95 | ETD59-Z | 0.382 | 368 | 139 | 51152 | 261 | 10200 |
| PEL95 | | | | | | | 12300 |
| PEM95 | | | | | | | 8600 |

* Typ. value for no specification tolerance

Core loss Temperature characteristics (Typ.) at 100kHz, 100mT ETD59-Z

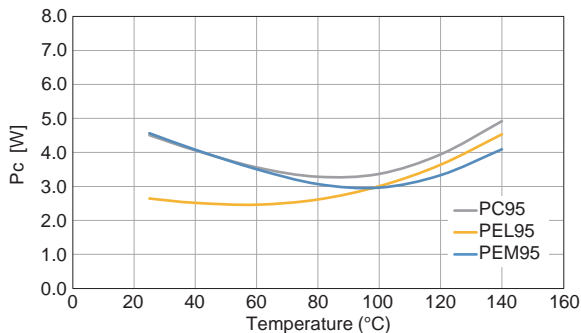

⚠ Please be sure to request delivery specifications that provide further details on the features and specifications of the products for proper and safe use. Please note that the contents may change without any prior notice due to reasons such as upgrading.

Mn-Zn

Large Size Ferrite Cores for High Power

Large PQ series

 **REMINDERS FOR USING THESE PRODUCTS**

Please be sure to read this manual thoroughly before using the products.

The products listed on this catalog are intended for use in general electronic equipment (AV equipment, telecommunications equipment, home appliances, amusement equipment, computer equipment, personal equipment, office equipment, measurement equipment, industrial robots) under a normal operation and use condition.

The products are not designed or warranted to meet the requirements of the applications listed below, whose performance and/or quality require a more stringent level of safety or reliability, or whose failure, malfunction or trouble could cause serious damage to society, person or property.

When using the products for specific purposes, please first make confirmations in areas such as safety, reliability, and quality.

Please understand that we are not in a position to be held responsible for any damage or the like caused by any use exceeding the range or conditions of this specification sheet or by any use in the specific applications.

- | | |
|---|--|
| (1) Aerospace/Aviation equipment | (8) Public information-processing equipment |
| (2) Transportation equipment (electric trains, ships, etc.) | (9) Military equipment |
| (3) Medical equipment | (10) Electric heating apparatus, burning equipment |
| (4) Power-generation control equipment | (11) Disaster prevention/crime prevention equipment |
| (5) Atomic energy-related equipment | (12) Safety equipment |
| (6) Seabed equipment | (13) Other applications that are not considered general-purpose applications |
| (7) Transportation control equipment | |

When using this product in general-purpose standard applications, you are kindly requested to take into consideration securing protection circuit/equipment or providing backup circuits, etc to ensure higher safety.

Large Size Ferrite Cores for High Power

Product compatible with RoHS directive
Halogen-free

Overview of the PQ Series

FEATURES

- Our original shape.
- Large size cores for transformers with large power outputs.
- Can also be used in reactors.
- PQ cores require less mounting area as transformers than E or EER cores.

APPLICATION

- Large size industrial equipment, transformers for consumer equipment
- Reactors
- Transformers and coils for power supplies (high density, low profile)

PART NUMBER CONSTRUCTION

| | | | | | | |
|-----------------|-------------------|--------------|---|------------------------------|---|------------------|
| PE22 | PQ | 78 | x | 39 | x | 42 |
| Material | Core shape | Width | | Height when assembled | | Thickness |
| PE22 | PQ | 78 | | 39 | | 42 |
| PC40 | | 107 | | 87 | | 70 |
| PC47 | | | | | | |
| PC95 | | | | | | |
| PEL95 | | | | | | |
| PEM95 | | | | | | |

RANGE OF USE AND STORAGE TEMPERATURE

| Temperature range | |
|----------------------------|--------------------------|
| Operating temperature (°C) | Storage temperature (°C) |
| -30 to +105 | -30 to +85 |

- RoHS Directive Compliant Product: See the following for more details related to RoHS Directive compliant products. <http://www.tdk.co.jp/rohs/>
- Halogen-free: Indicates that Cl content is less than 900ppm, Br content is less than 900ppm, and that the total Cl and Br content is less than 1500ppm.

Please be sure to request delivery specifications that provide further details on the features and specifications of the products for proper and safe use. Please note that the contents may change without any prior notice due to reasons such as upgrading.

Mn-Zn PQ Cores



SHAPES AND DIMENSIONS

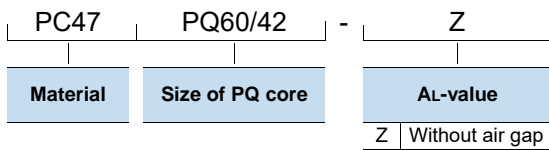
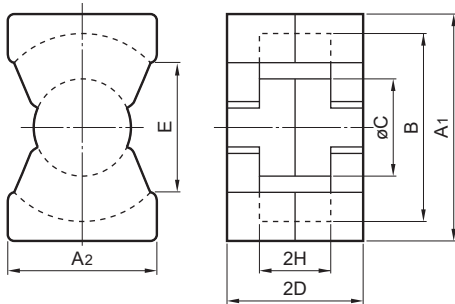

| Material | Part No. | | Dimensions (mm) | | | | | | |
|----------|-------------|------------|-----------------|----------|--------|----------|----------|--------|----------|
| | Shape | Dimensions | A1 | A2 | B min. | φC | 2D | E min. | 2H |
| PC47 | PQ60/42-Z | | 59.0±1.0 | 39.0±0.7 | 49.5 | 23.5±0.5 | 41.5±0.5 | 37.8 | 25.1±0.6 |
| PC95 | | | | | | | | | |
| PEL95 | | | | | | | | | |
| PEM95 | | | | | | | | | |
| PC47 | PQ60/52-Z | | 59.0±1.0 | 39.0±0.7 | 49.5 | 23.5±0.5 | 51.5±0.5 | 37.8 | 35.1±0.6 |
| PC95 | | | | | | | | | |
| PEL95 | | | | | | | | | |
| PEM95 | | | | | | | | | |
| PC47 | PQ65/44-Z | | 65.0±1.0 | 45.0±0.7 | 55 | 26.0±0.5 | 43.5±0.5 | 40.8 | 25.5±0.6 |
| PC95 | | | | | | | | | |
| PEL95 | | | | | | | | | |
| PEM95 | | | | | | | | | |
| PC47 | PQ65/54-Z | | 65.0±1.0 | 45.0±0.7 | 55 | 26.0±0.5 | 53.5±0.5 | 40.8 | 35.5±0.6 |
| PC95 | | | | | | | | | |
| PEL95 | | | | | | | | | |
| PEM95 | | | | | | | | | |
| PE22 | PQ78x39x42 | | 78.5±1.5 | 42.0±0.8 | 69.0 | 25.5±0.5 | 39.4±0.6 | 60.0 | 25.8±1.0 |
| PC40 | | | | | | | | | |
| PC95 | | | | | | | | | |
| PEL95 | | | | | | | | | |
| PEM95 | | | | | | | | | |
| PE22 | PQ107x87x70 | | 107.0±2.0 | 70.0±1.5 | 93.7 | 41.0±1.0 | 87.0±1.5 | 72.5 | 56.0±1.5 |
| PC40 | | | | | | | | | |
| PC95 | | | | | | | | | |
| PEL95 | | | | | | | | | |
| PEM95 | | | | | | | | | |

⚠ Please be sure to request delivery specifications that provide further details on the features and specifications of the products for proper and safe use.
Please note that the contents may change without any prior notice due to reasons such as upgrading.

Mn-Zn PQ Cores

| Material | Part No. Shape Dimensions | Effective parameter | | Effective cross-sectional area Ae (mm ²) | Effective magnetic path length Le (mm) | Effective core volume Ve (mm ³) | Weigh (Approx.) (g) | Electrical characteristics | | | | | |
|----------|------------------------------|---------------------------|--|--|--|---|------------------------|--|---------------------------------------|-------|-------|--------|--------|
| | | Core factor | | | | | | AL-value (nH/N ²) 1kHz, 0.4A/m | Core loss (W)mas. 100kHz, 150mT | | | | |
| | | C1 (mm ⁻¹) | C2x10 ⁻² (mm ⁻³) | | | | | | 23 °C | 25 °C | 80 °C | 100 °C | 120 °C |
| PC47 | PQ60/42-Z | 0.203 | — | 483 | 98.1 | 47360 | 265 | 10,500±25% | — | — | 9.5 | — | |
| PC95 | | | | | | | | 14,300±25% | 11.0 | 10.0 | — | 12.5 | |
| PEL95 | | | | | | | | — | — | — | — | — | |
| PEM95 | | | | | | | | — | — | — | — | — | |
| PC47 | PQ60/52-Z | 0.248 | — | 477 | 118 | 56237 | 310 | 8,500±25% | — | — | 11.3 | — | |
| PC95 | | | | | | | | 11,200±25% | 13.0 | 11.8 | — | 14.9 | |
| PEL95 | | | | | | | | 12,500±25% | 6.7 | 6.8 | — | 10.0 | |
| PEM95 | | | | | | | | 10,000±25% | 13.2 | 9.6 | — | 9.0 | |
| PC47 | PQ65/44-Z | 0.171 | — | 604 | 103 | 62460 | 355 | 12,600±25% | — | — | 12.5 | — | |
| PC95 | | | | | | | | 15,500±25% | 14.4 | 13.2 | — | 16.5 | |
| PEL95 | | | | | | | | — | — | — | — | — | |
| PEM95 | | | | | | | | — | — | — | — | — | |
| PC47 | PQ65/54-Z | 0.207 | — | 597 | 123 | 73552 | 410 | 10,000±25% | — | — | 14.8 | — | |
| PC95 | | | | | | | | 13,500±25% | 17.0 | 15.5 | — | 19.5 | |
| PEL95 | | | | | | | | 16,500±25% | 8.0 | 9.5 | — | 13.1 | |
| PEM95 | | | | | | | | 12,500±25% | 12.6 | 9.7 | — | 11.6 | |
| PE22 | PQ78x39x42 | 0.2473 | 0.05153 | 480 | 119 | 56900 | 304 | 7940±25 | — | — | — | — | |
| PC40 | | | | | | | | 9790±25% | — | — | — | — | |
| PC95 | | | | | | | | — | — | — | — | — | |
| PEL95 | | | | | | | | — | — | — | — | — | |
| PEM95 | — | — | — | — | — | — | — | — | — | — | — | | |
| PE22 | PQ107x87x70 | 0.1426 | 0.009989 | 1428 | 204 | 291312 | 1560 | 15470±25% | — | — | — | — | |
| PC40 | | | | | | | | 18210±25% | — | — | — | — | |
| PC95 | | | | | | | | — | — | — | — | — | |
| PEL95 | | | | | | | | — | — | — | — | — | |
| PEM95 | — | — | — | — | — | — | — | — | — | — | — | | |

□ Core loss Temperature characteristics (Typ.)

PQ60/52-Z at 100kHz, 150mT

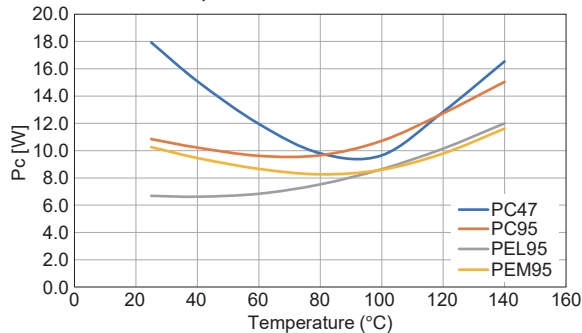

PQ65/54-Z at 100kHz, 150mT

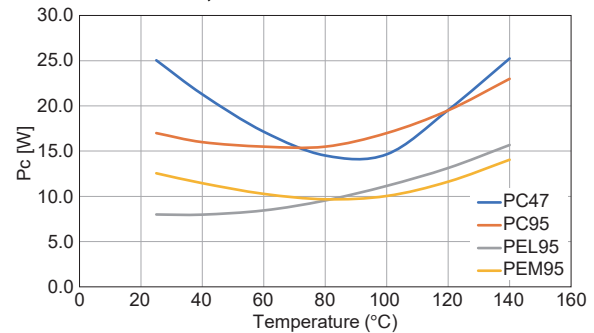

⚠ Please be sure to request delivery specifications that provide further details on the features and specifications of the products for proper and safe use. Please note that the contents may change without any prior notice due to reasons such as upgrading.

Mn-Zn PQ series Part No.: PC47PQ60/42-Z

SHAPES AND DIMENSIONS

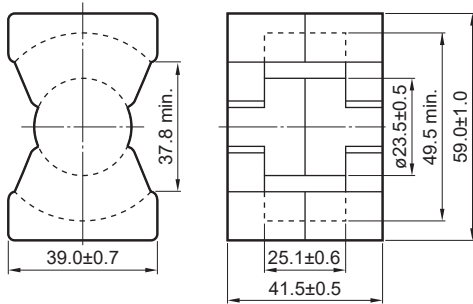

| Effective parameter | | | | | | | | Electrical characteristics | |
|------------------------|---|---|--|--|---|--|----------------|---------------------------------|--------------------------------------|
| Core factor | Effective magnetic path length l_e (mm) | Effective cross-sectional area A_e (mm ²) | Effective core volume V_e (mm ³) | Cross-sectional center pole area A_{cp} (mm ²) | Minimum cross-sectional center pole area $A_{cp \text{ min.}}$ (mm ²) | Cross-sectional winding area of core A_{cw} (mm ²) | Weight (g/set) | AL-value * (nH/N ²) | Core loss (W)max. 100kHz 150mT 100°C |
| C1 (mm ⁻¹) | 98.1 | 483 | 47360 | 433 | 415 | 338 | 265 | 10,500±25% | 9.5 |

* Coil: ø0.4 2UEW 100Ts

NI limit vs. AL-value (Typ.)

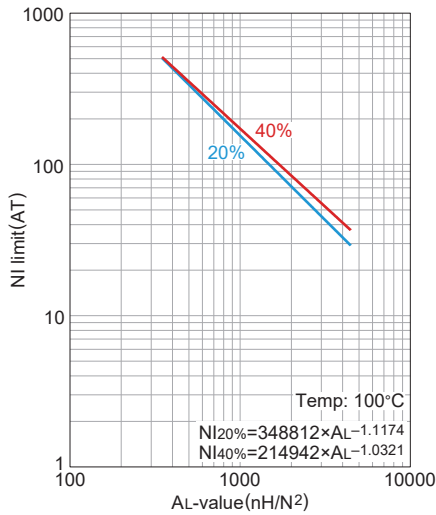

The 20% and 40% graph shows when a 20% and 40% drop from the initial AL-value has been made due to the DC superimposition.

AL-value vs. Air gap length (Typ.)

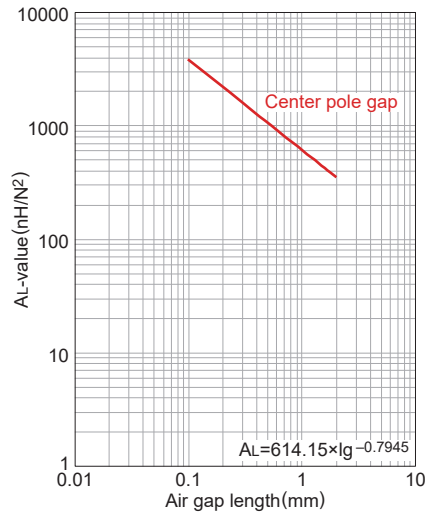

Measuring conditions
 • Coil : ø0.4 2UEW 100Ts
 • Frequency : 1kHz
 • Current level : 0.5mA
 • Ambient temperature : 25°C

Temperature rise vs. Total loss (Typ.)

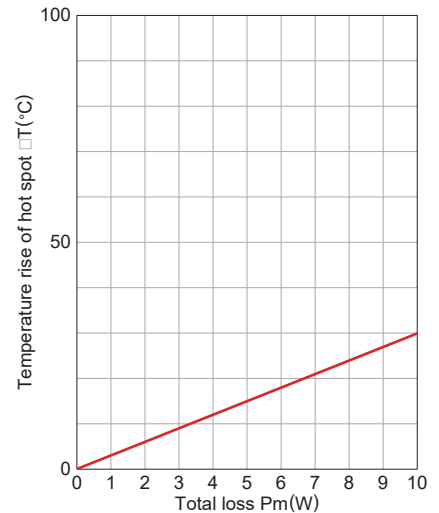

Measuring conditions
 • Room space: approx. 400x300x 300cm
 • Ambient temperature : 25°C
 • Humidity: 45%(%)RH.

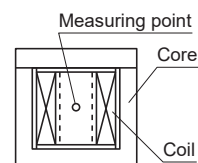

⚠ Please be sure to request delivery specifications that provide further details on the features and specifications of the products for proper and safe use. Please note that the contents may change without any prior notice due to reasons such as upgrading.

Mn-Zn PQ series Part No.: PC95PQ60/42-Z

SHAPES AND DIMENSIONS

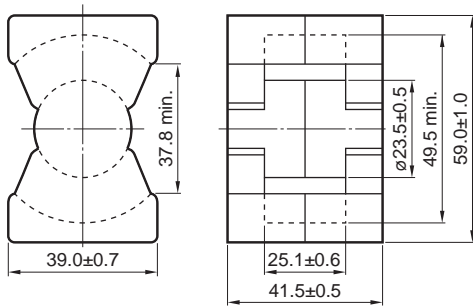

| Effective parameter | | | | | | | | Electrical characteristics | | | | |
|---------------------------|---|---|--|--|---|--|----------------|----------------------------|---------|-----------|-------|------|
| Core factor | Effective magnetic path length l_e (mm) | Effective cross-sectional area A_e (mm ²) | Effective core volume V_e (mm ³) | Cross-sectional center pole area A_{cp} (mm ²) | Minimum cross-sectional center pole area $A_{cp \text{ min.}}$ (mm ²) | Cross-sectional winding area of core A_{cw} (mm ²) | Weight (g/set) | AL-value * | | Core loss | | |
| C_1 (mm ⁻¹) | | | | | | | | (nH/N ²) | (W)max. | | | |
| 0.203 | 98.1 | 483 | 47360 | 433 | 415 | 338 | 265 | 14,300±25% | 1kHz | 100kHz | 150mT | |
| | | | | | | | | | 25°C | 80°C | 120°C | |
| | | | | | | | | | | 11.0 | 10.0 | 12.5 |

* Coil: $\phi 0.4$ 2UEW 100Ts

NI limit vs. AL-value (Typ.)

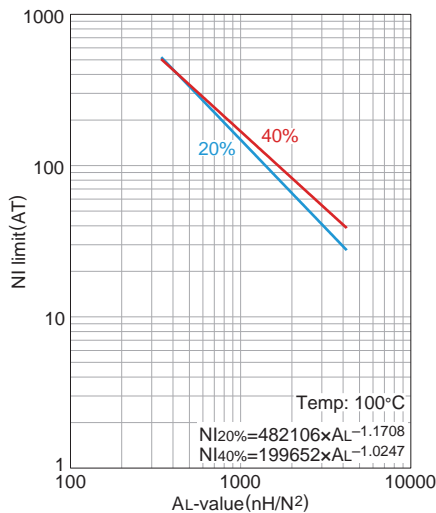

The 20% and 40% graph shows when a 20% and 40% drop from the initial AL-value has been made due to the DC superimposition.

AL-value vs. Air gap length (Typ.)

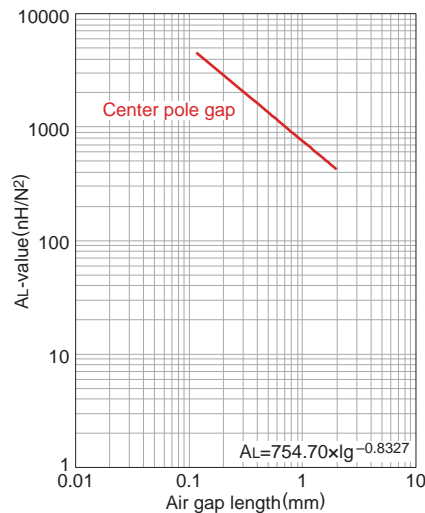

Measuring conditions

- Coil : $\phi 0.4$ 2UEW 100Ts
- Frequency : 1kHz
- Current level : 0.5mA
- Ambient temperature : 25°C

Temperature rise vs. Total loss (Typ.)

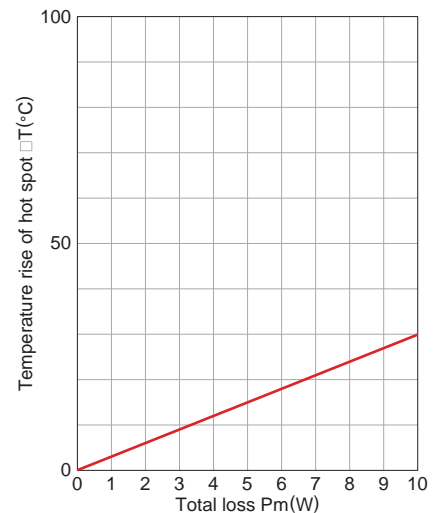

Measuring conditions

- Room space: approx. 400x300x 300cm
- Ambient temperature : 25°C
- Humidity: 45%(%)RH.

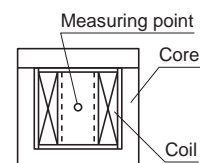

⚠ Please be sure to request delivery specifications that provide further details on the features and specifications of the products for proper and safe use. Please note that the contents may change without any prior notice due to reasons such as upgrading.

Mn-Zn PQ series **Part No.: PC47PQ60/52-Z**

■ SHAPES AND DIMENSIONS

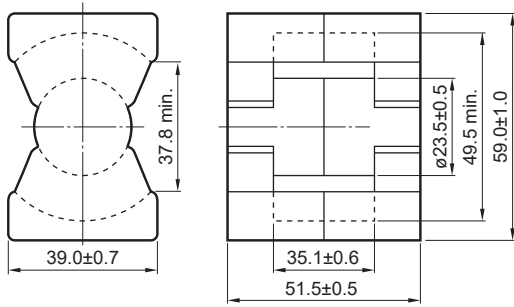

| Effective parameter | | | | | | | | Electrical characteristics | |
|------------------------------|--------------------------------------|--------------------------------------|-----------------------------|---|--|---|---------|---------------------------------------|-------------------------------------|
| Core factor | Effective magnetic path length l_e | Effective cross-sectional area A_e | Effective core volume V_e | Cross-sectional center pole area A_{cp} | Minimum cross-sectional center pole area $A_{cp \text{ min.}}$ | Cross-sectional winding area of core A_{cw} | Weight | AL-value * | Core loss |
| C_1 (mm ⁻¹) | (mm) | (mm ²) | (mm ³) | (mm ²) | (mm ²) | (mm ²) | (g/set) | (nH/N ²) 1kHz 0.5mA | (W)max. 100kHz 150mT 100°C |
| 0.248 | 118 | 477 | 56237 | 433 | 415 | 473 | 310 | 8,500±25% | 11.3 |

* Coil: ø0.4 2UEW 100Ts

NI limit vs. AL-value (Typ.)

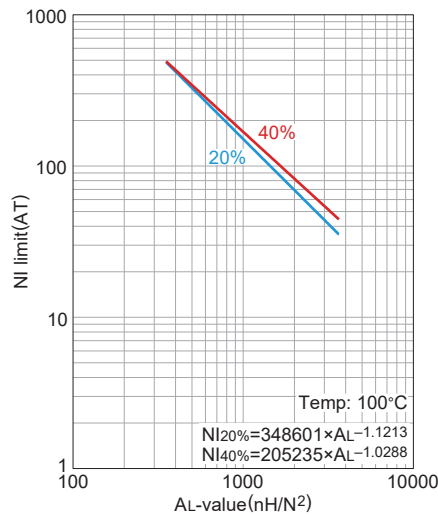

The 20% and 40% graph shows when a 20% and 40% drop from the initial AL-value has been made due to the DC superimposition.

AL-value vs. Air gap length (Typ.)

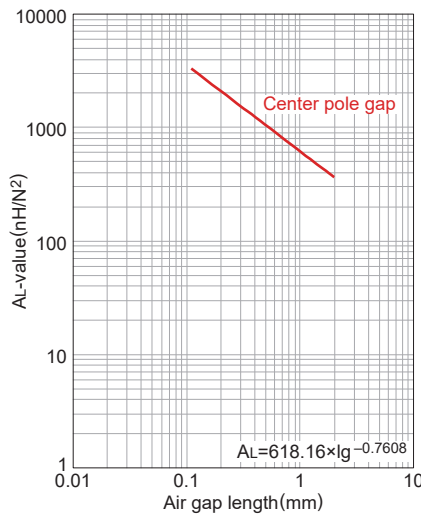

Measuring conditions
 • Coil : ø0.4 2UEW 100Ts
 • Frequency : 1kHz
 • Current level : 0.5mA
 • Ambient temperature : 25°C

Temperature rise vs. Total loss (Typ.)

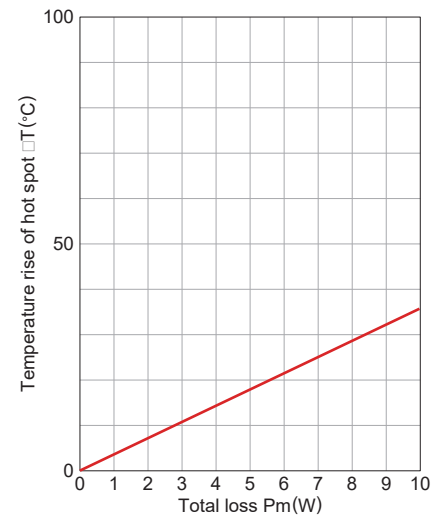

Measuring conditions
 • Room space: approx. 400x300x 300cm
 • Ambient temperature : 25°C
 • Humidity: 45%(%)RH.

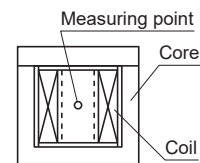

⚠ Please be sure to request delivery specifications that provide further details on the features and specifications of the products for proper and safe use. Please note that the contents may change without any prior notice due to reasons such as upgrading.

Mn-Zn PQ series **Part No.: PC95PQ60/52-Z**

■ SHAPES AND DIMENSIONS

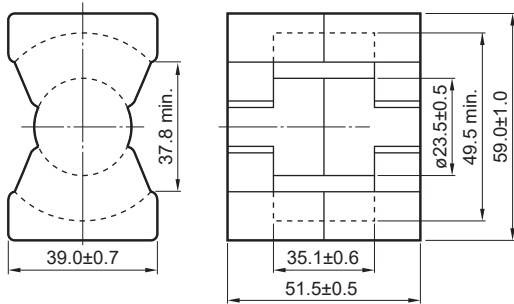

| Effective parameter | | | | | | | | Electrical characteristics | | | | |
|---------------------------|---|---|--|--|---|--|----------------|----------------------------|---------|-----------|-------|-------|
| Core factor | Effective magnetic path length l_e (mm) | Effective cross-sectional area A_e (mm ²) | Effective core volume V_e (mm ³) | Cross-sectional center pole area A_{cp} (mm ²) | Minimum cross-sectional center pole area $A_{cp \text{ min.}}$ (mm ²) | Cross-sectional winding area of core A_{cw} (mm ²) | Weight (g/set) | AL-value * | | Core loss | | |
| C_1 (mm ⁻¹) | | | | | | | | (nH/N ²) | (W)max. | | | |
| 0.248 | 118 | 477 | 56237 | 433 | 415 | 473 | 310 | 11,200±25% | 1kHz | 100kHz | 150mT | |
| | | | | | | | | | 0.5mA | 25°C | 80°C | 120°C |
| | | | | | | | | | | 13.0 | 11.8 | 14.9 |

* Coil: ø0.4 2UEW 100Ts

NI limit vs. AL-value (Typ.)

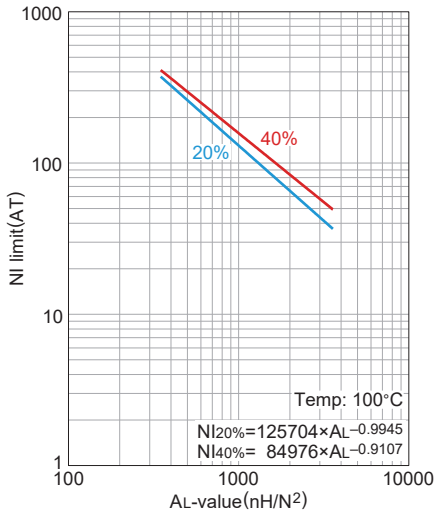

The 20% and 40% graph shows when a 20% and 40% drop from the initial AL-value has been made due to the DC superimposition.

AL-value vs. Air gap length (Typ.)

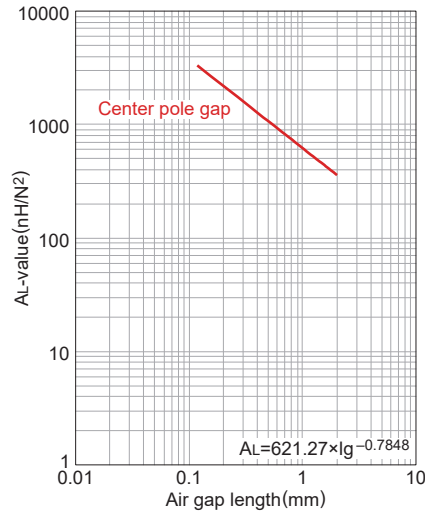

Measuring conditions
 • Coil : ø0.4 2UEW 100Ts
 • Frequency : 1kHz
 • Current level : 0.5mA
 • Ambient temperature : 25°C

Temperature rise vs. Total loss (Typ.)

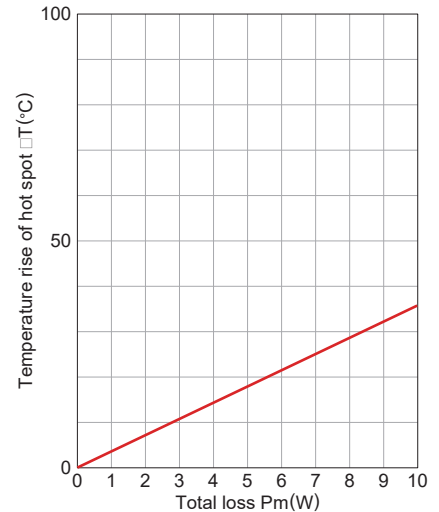

Measuring conditions
 • Room space: approx. 400x300x 300cm
 • Ambient temperature : 25°C
 • Humidity: 45%(%)RH.

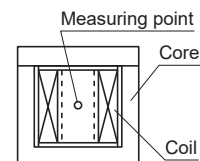

⚠ Please be sure to request delivery specifications that provide further details on the features and specifications of the products for proper and safe use. Please note that the contents may change without any prior notice due to reasons such as upgrading.

Mn-Zn PQ series Part No.: PC47PQ65/44-Z

SHAPES AND DIMENSIONS

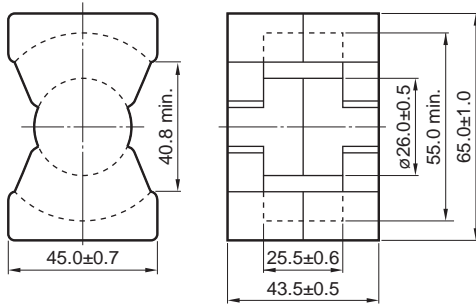

| Effective parameter | | | | | | | | Electrical characteristics | |
|---------------------|---|---|--|--|---|--|----------------|---------------------------------|--------------------------------------|
| Core factor | Effective magnetic path length l_e (mm) | Effective cross-sectional area A_e (mm ²) | Effective core volume V_e (mm ³) | Cross-sectional center pole area A_{cp} (mm ²) | Minimum cross-sectional center pole area $A_{cp \text{ min.}}$ (mm ²) | Cross-sectional winding area of core A_{cw} (mm ²) | Weight (g/set) | AL-value * (nH/N ²) | Core loss (W)max. 100kHz 150mT 100°C |
| 0.171 | 103 | 604 | 62460 | 531 | 511 | 382 | 355 | 12,600±25% | 12.5 |

* Coil: ϕ 0.4 2UEW 100Ts

NI limit vs. AL-value (Typ.)

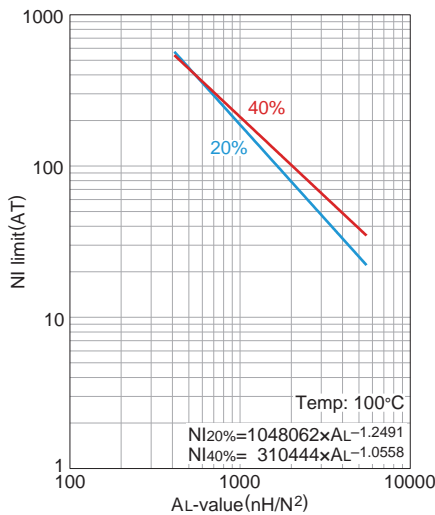

The 20% and 40% graph shows when a 20% and 40% drop from the initial AL-value has been made due to the DC superimposition.

AL-value vs. Air gap length (Typ.)

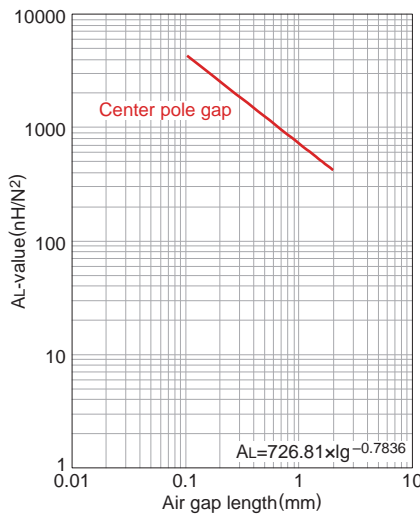

Measuring conditions
 • Coil : ϕ 0.4 2UEW 100Ts
 • Frequency : 1kHz
 • Current level : 0.5mA
 • Ambient temperature : 25°C

Temperature rise vs. Total loss (Typ.)

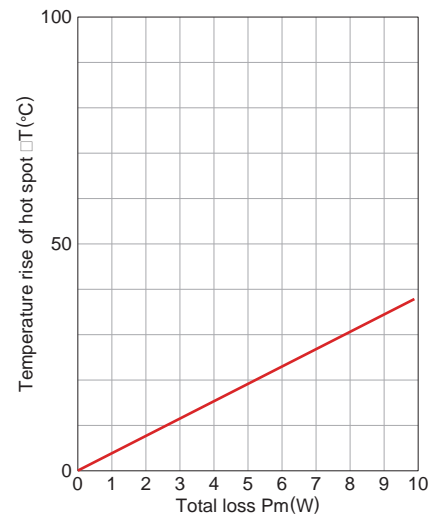

Measuring conditions
 • Room space: approx. 400x300x 300cm
 • Ambient temperature : 25°C
 • Humidity: 45(%)RH.

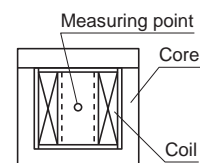

⚠ Please be sure to request delivery specifications that provide further details on the features and specifications of the products for proper and safe use. Please note that the contents may change without any prior notice due to reasons such as upgrading.

Mn-Zn PQ series **Part No.: PC95PQ65/44-Z**

SHAPES AND DIMENSIONS

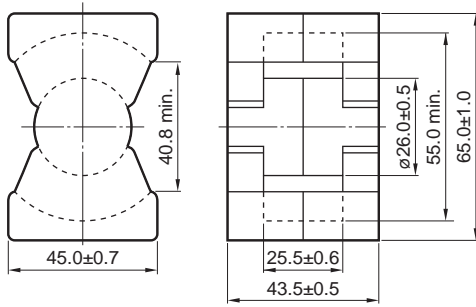

| Effective parameter | | | | | | | | Electrical characteristics | | | |
|---------------------------|---|---|--|--|---|--|----------------|----------------------------|---------|-----------|-------|
| Core factor | Effective magnetic path length l_e (mm) | Effective cross-sectional area A_e (mm ²) | Effective core volume V_e (mm ³) | Cross-sectional center pole area A_{cp} (mm ²) | Minimum cross-sectional center pole area $A_{cp \text{ min.}}$ (mm ²) | Cross-sectional winding area of core A_{cw} (mm ²) | Weight (g/set) | AL-value * | | Core loss | |
| C_1 (mm ⁻¹) | | | | | | | | (nH/N ²) | (W)max. | | |
| | | | | | | | | 1kHz 0.5mA | 25°C | 80°C | 120°C |
| 0.171 | 103 | 604 | 62460 | 531 | 511 | 382 | 355 | 15,500±25% | 14.4 | 13.2 | 16.5 |

* Coil: $\varnothing 0.4$ 2UEW 100Ts

NI limit vs. AL-value (Typ.)

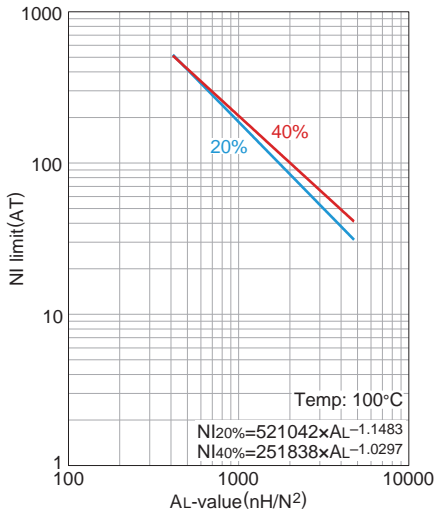

The 20% and 40% graph shows when a 20% and 40% drop from the initial AL-value has been made due to the DC superimposition.

AL-value vs. Air gap length (Typ.)

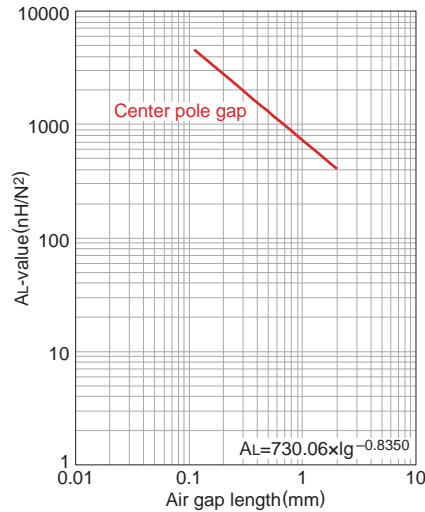

Measuring conditions
 • Coil : $\varnothing 0.4$ 2UEW 100Ts
 • Frequency : 1kHz
 • Current level : 0.5mA
 • Ambient temperature : 25°C

Temperature rise vs. Total loss (Typ.)

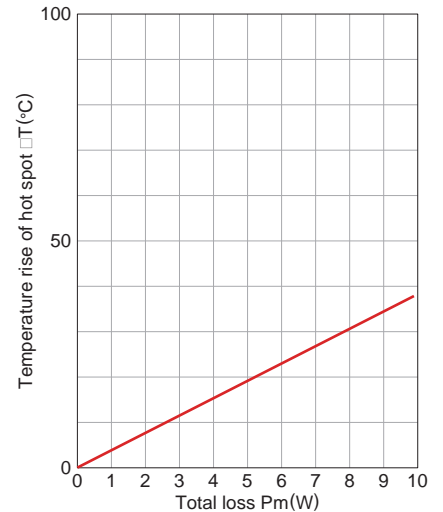

Measuring conditions
 • Room space: approx. 400x300x 300cm
 • Ambient temperature : 25°C
 • Humidity: 45%(%)RH.

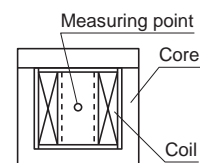

⚠ Please be sure to request delivery specifications that provide further details on the features and specifications of the products for proper and safe use. Please note that the contents may change without any prior notice due to reasons such as upgrading.

Mn-Zn PQ series Part No.: PC47PQ65/54-Z

SHAPES AND DIMENSIONS

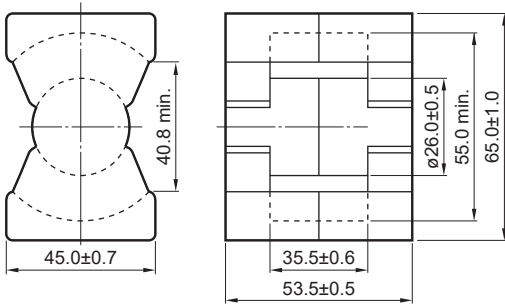

| Effective parameter | | | | | | | | Electrical characteristics | |
|---------------------|---|---|--|--|---|--|----------------|---------------------------------|--------------------------------------|
| Core factor | Effective magnetic path length l_e (mm) | Effective cross-sectional area A_e (mm ²) | Effective core volume V_e (mm ³) | Cross-sectional center pole area A_{cp} (mm ²) | Minimum cross-sectional center pole area $A_{cp \text{ min.}}$ (mm ²) | Cross-sectional winding area of core A_{cw} (mm ²) | Weight (g/set) | AL-value * (nH/N ²) | Core loss (W)max. 100kHz 150mT 100°C |
| 0.207 | 123 | 597 | 73552 | 531 | 511 | 532 | 410 | 10,000±25% | 14.8 |

* Coil: ϕ 0.4 2UEW 100Ts

NI limit vs. AL-value (Typ.)

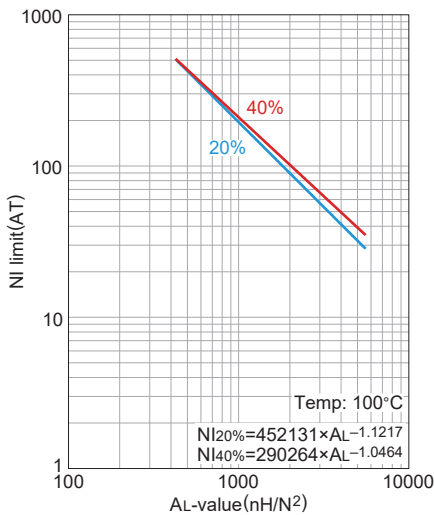

The 20% and 40% graph shows when a 20% and 40% drop from the initial AL-value has been made due to the DC superimposition.

AL-value vs. Air gap length (Typ.)

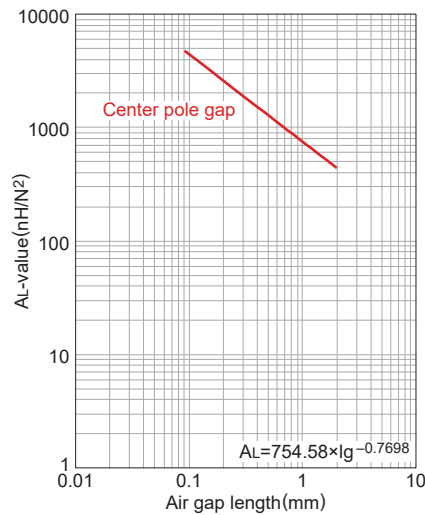

Measuring conditions
 • Coil : ϕ 0.4 2UEW 100Ts
 • Frequency : 1kHz
 • Current level : 0.5mA
 • Ambient temperature : 25°C

Temperature rise vs. Total loss (Typ.)

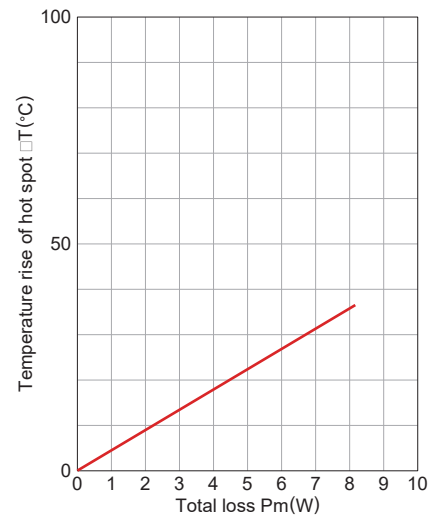

Measuring conditions
 • Room space: approx. 400x300x 300cm
 • Ambient temperature : 25°C
 • Humidity: 45%(%)RH.

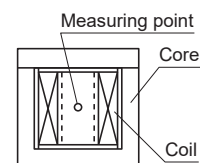

⚠ Please be sure to request delivery specifications that provide further details on the features and specifications of the products for proper and safe use. Please note that the contents may change without any prior notice due to reasons such as upgrading.

Mn-Zn PQ series **Part No.: PC95PQ65/54-Z**

■ SHAPES AND DIMENSIONS

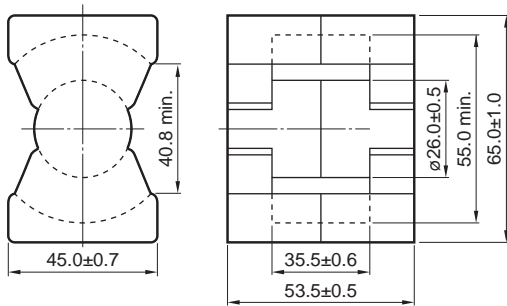

| Effective parameter | | | | | | | | Electrical characteristics | | | | | | | |
|---------------------|---|---|--|--|---|--|----------------|----------------------------|---------|-----------|-------|------|------|-------|------|
| Core factor | Effective magnetic path length l_e (mm) | Effective cross-sectional area A_e (mm ²) | Effective core volume V_e (mm ³) | Cross-sectional center pole area A_{cp} (mm ²) | Minimum cross-sectional center pole area $A_{cp \text{ min.}}$ (mm ²) | Cross-sectional winding area of core A_{cw} (mm ²) | Weight (g/set) | AL-value * | | Core loss | | | | | |
| C_1 | (mm ⁻¹) | (mm) | (mm ³) | (mm ²) | (mm ²) | (mm ²) | (g/set) | (nH/N ²) | (W)max. | | | | | | |
| 0.207 | 123 | 597 | 73552 | 531 | 511 | 532 | 410 | 13,500 ± 25% | 1kHz | 100kHz | 150mT | 25°C | 80°C | 120°C | |
| | | | | | | | | | 0.5mA | | | | 17.0 | 15.5 | 19.5 |

* Coil: ø0.4 2UEW 100Ts

NI limit vs. AL-value (Typ.)

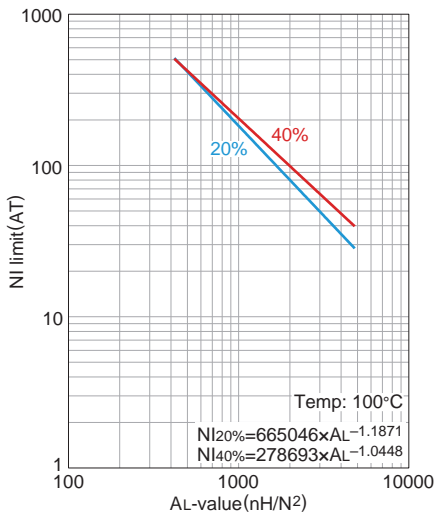

The 20% and 40% graph shows when a 20% and 40% drop from the initial AL-value has been made due to the DC superimposition.

AL-value vs. Air gap length (Typ.)

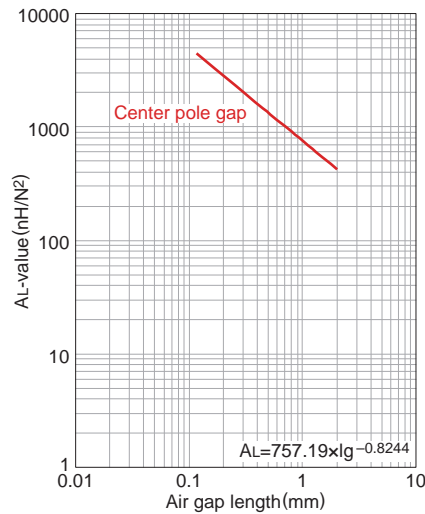

Measuring conditions
 • Coil : ø0.4 2UEW 100Ts
 • Frequency : 1kHz
 • Current level : 0.5mA
 • Ambient temperature : 25°C

Temperature rise vs. Total loss (Typ.)

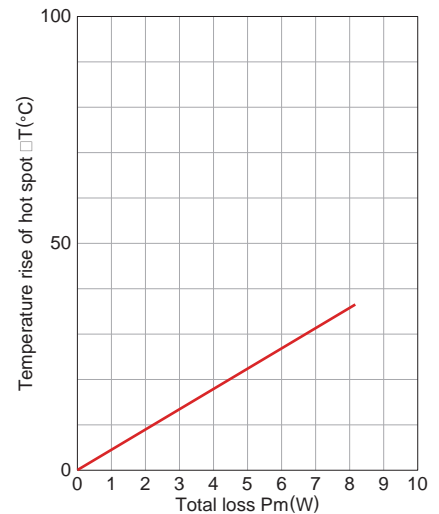

Measuring conditions
 • Room space: approx. 400x300x 300cm
 • Ambient temperature : 25°C
 • Humidity: 45%(%)RH.

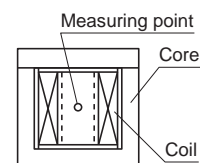

⚠ Please be sure to request delivery specifications that provide further details on the features and specifications of the products for proper and safe use. Please note that the contents may change without any prior notice due to reasons such as upgrading.

Mn-Zn PQ series Part No.: PE22 PQ78X39X42

SHAPES AND DIMENSIONS

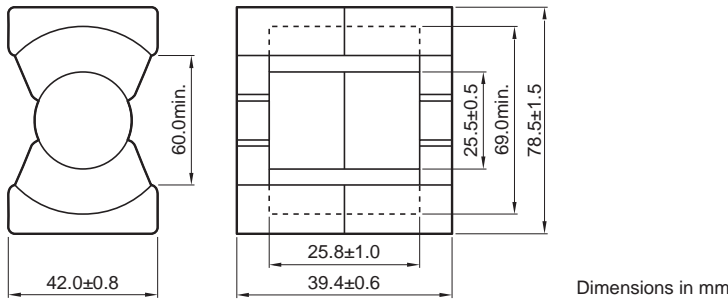

| Effective parameter | | | | | | | | Electrical characteristics | |
|------------------------------|---|--------------------------------|--------------------------------|-----------------------------|----------------------------------|-------------------------------|--------------------------------|----------------------------|--|
| Core factor | | Effective magnetic path length | Effective cross-sectional area | Effective core volume | Cross-sectional center pole area | Minimum cross-sectional area | Winding cross-sectional area | Weigh (approx.) | AL-value |
| C_1 (mm ⁻¹) | $C_2 \times 10^{-2}$ (mm ⁻³) | l_e (mm) | A_e (mm ²) | V_e (mm ³) | A_c (mm ²) | A min.* (mm ²) | A_{cw} (mm ²) | (g) | (nH/N ²) 1kHz 0.4A/m 23°C |
| 0.2473 | 0.05153 | 119 | 480 | 56900 | 510 | 510C* | 570 | 304 | 7940±25% |

- * The symbol followed A min. value shows minimum cross-sectional area part.
C is center pole part, L: is outer pole part, B is the back part.
- Available customize core like this. Please specify when ordering.
- Calculated output power (forward converter mode): 1.6kW (100kHz)

NI limit vs. AL-value

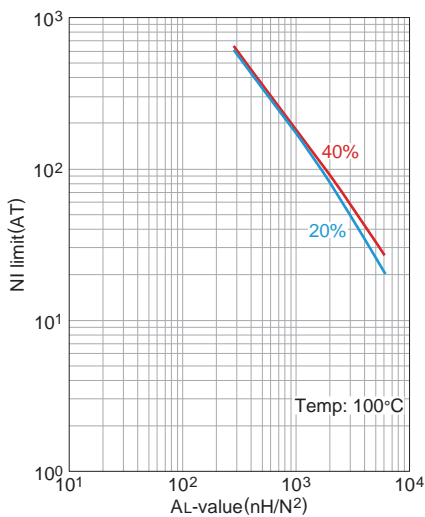

The 20% and 40% graph shows when a 20% and 40% drop from the initial AL-value has been made due to the DC superimposition.

AL-value vs. Air gap length

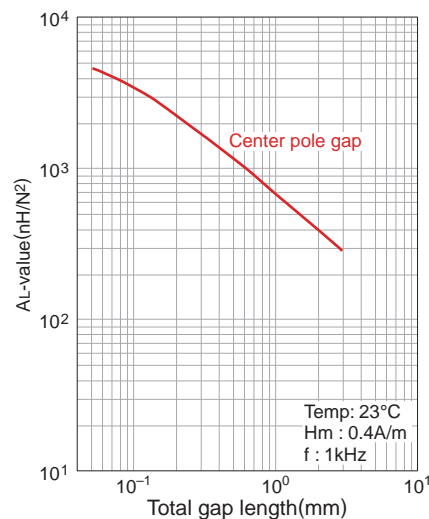

⚠ Please be sure to request delivery specifications that provide further details on the features and specifications of the products for proper and safe use. Please note that the contents may change without any prior notice due to reasons such as upgrading.

Mn-Zn PQ series Part No.: PC40 PQ78X39X42

SHAPES AND DIMENSIONS

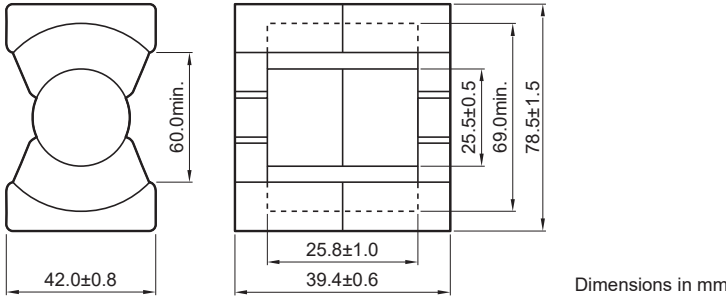

| Effective parameter | | | | | | | | | Electrical characteristics |
|------------------------------|---|--------------------------------|--------------------------------|-----------------------------|----------------------------------|-------------------------------|--------------------------------|-----------------|--|
| Core factor | | Effective magnetic path length | Effective cross-sectional area | Effective core volume | Cross-sectional center pole area | Minimum cross-sectional area | Winding cross-sectional area | Weigh (approx.) | AL-value |
| C_1 (mm ⁻¹) | $C_2 \times 10^{-2}$ (mm ⁻³) | l_e (mm) | A_e (mm ²) | V_e (mm ³) | A_c (mm ²) | A min.* (mm ²) | A_{cw} (mm ²) | (g) | (nH/N ²) 1kHz 0.4A/m 23°C |
| 0.2473 | 0.05153 | 119 | 480 | 56900 | 510 | 510C* | 570 | 304 | 9790±25% |

- * The symbol followed A min. value shows minimum cross-sectional area part.
C is center pole part, L: is outer pole part, B is the back part.
- Available customize core like this. Please specify when ordering.
- Calculated output power (forward converter mode): 1.7kW (100kHz)

NI limit vs. AL-value

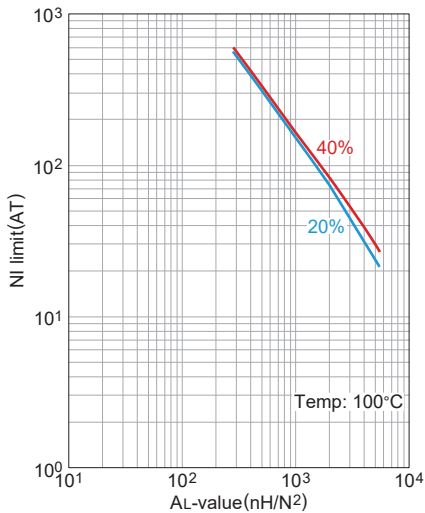

The 20% and 40% graph shows when a 20% and 40% drop from the initial AL-value has been made due to the DC superimposition.

AL-value vs. Air gap length

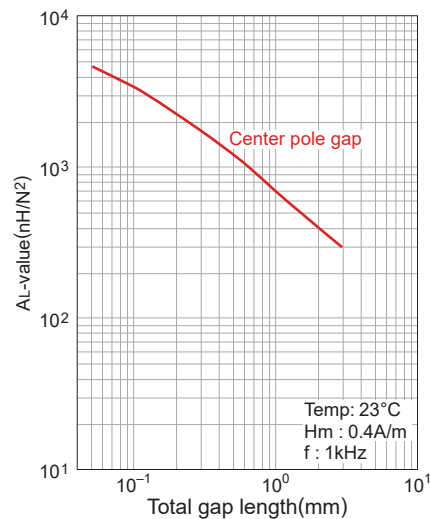

⚠ Please be sure to request delivery specifications that provide further details on the features and specifications of the products for proper and safe use. Please note that the contents may change without any prior notice due to reasons such as upgrading.

Mn-Zn PQ series Part No.: PE22 PQ107X87X70

SHAPES AND DIMENSIONS

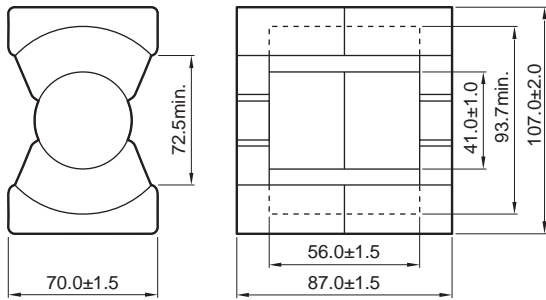

Dimensions in mm

| Effective parameter | | | | | | | | | Electrical characteristics |
|------------------------------|---|--------------------------------|--------------------------------|-----------------------------|----------------------------------|-------------------------------|--------------------------------|-----------------|--|
| Core factor | | Effective magnetic path length | Effective cross-sectional area | Effective core volume | Cross-sectional center pole area | Minimum cross-sectional area | Winding cross-sectional area | Weigh (approx.) | AL-value |
| C_1 (mm ⁻¹) | $C_2 \times 10^{-2}$ (mm ⁻³) | l_e (mm) | A_e (mm ²) | V_e (mm ³) | A_c (mm ²) | A min.* (mm ²) | A_{cw} (mm ²) | (g) | (nH/N ²) 1kHz 0.4A/m 23°C |
| 0.1426 | 0.009989 | 204 | 1428 | 290600 | 1320 | 1320C* | 1540 | 1560 | 14570±25% |

* The symbol followed A min. value shows minimum cross-sectional area part.

C is center pole part, L: is outer pole part, B is the back part.

• Available customize core like this. Please specify when ordering.

○ Calculated output power (forward converter mode): 8.3kW (100kHz)

NI limit vs. AL-value

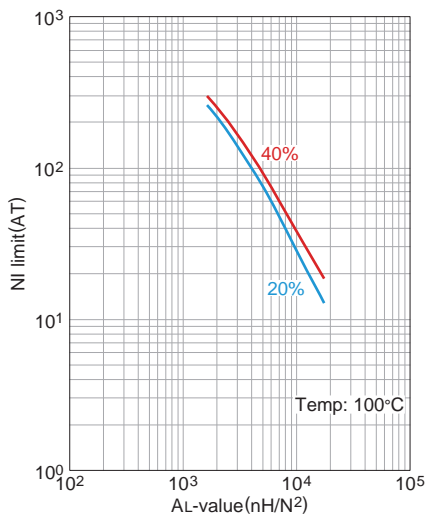

The 20% and 40% graph shows when a 20% and 40% drop from the initial AL-value has been made due to the DC superimposition.

AL-value vs. Air gap length

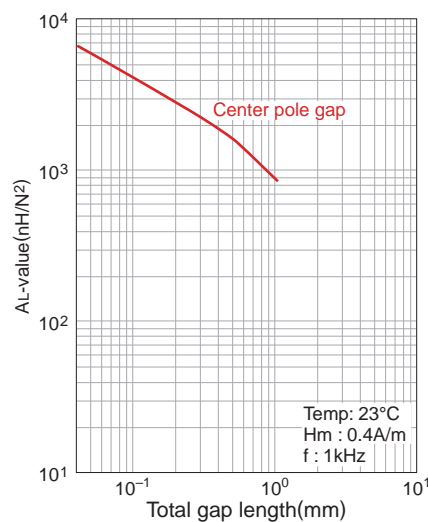

Mn-Zn PQ series Part No.: PC40 PQ107X87X70

SHAPES AND DIMENSIONS

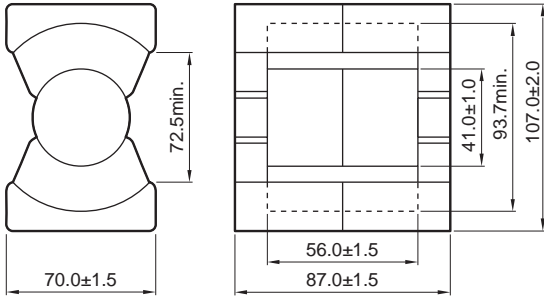

Dimensions in mm

| Effective parameter | | | | | | | | Electrical characteristics | |
|-------------------------------|--|--------------------------------|--------------------------------|----------------------------|----------------------------------|------------------------------|-------------------------------|----------------------------|--|
| Core factor | | Effective magnetic path length | Effective cross-sectional area | Effective core volume | Cross-sectional center pole area | Minimum cross-sectional area | Winding cross-sectional area | Weigh (approx.) | AL-value |
| C_1 (mm^{-1}) | $C_2 \times 10^{-2}$ (mm^{-3}) | l_e (mm) | A_e (mm^2) | V_e (mm^3) | A_c (mm^2) | A min.* (mm^2) | A_{cw} (mm^2) | (g) | (nH/N^2) 1kHz 0.4A/m 23°C |
| 0.1426 | 0.009989 | 204 | 1428 | 290600 | 1320 | 1320C* | 1540 | 1560 | 18210±25% |

* The symbol followed A min. value shows minimum cross-sectional area part.

C is center pole part, L: is outer pole part, B is the back part.

• Available customize core like this. Please specify when ordering.

○ Calculated output power (forward converter mode): 9.0kW (100kHz)

NI limit vs. AL-value

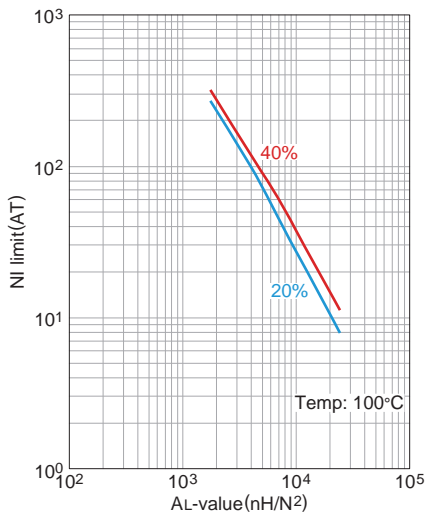

The 20% and 40% graph shows when a 20% and 40% drop from the initial AL-value has been made due to the DC superimposition.

AL-value vs. Air gap length

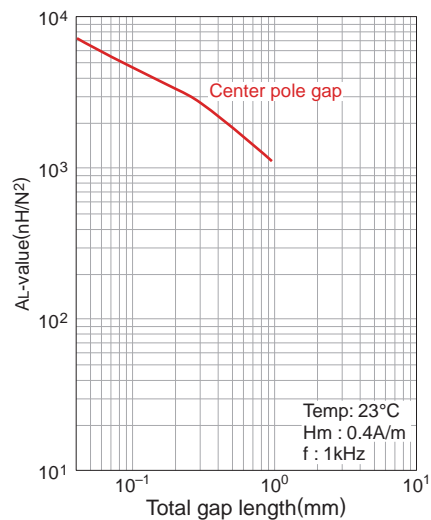

⚠ Please be sure to request delivery specifications that provide further details on the features and specifications of the products for proper and safe use. Please note that the contents may change without any prior notice due to reasons such as upgrading.

Mn-Zn

Large Size Ferrite Cores for High Power

T series

 **REMINDERS FOR USING THESE PRODUCTS**

Please be sure to read this manual thoroughly before using the products.

The products listed on this catalog are intended for use in general electronic equipment (AV equipment, telecommunications equipment, home appliances, amusement equipment, computer equipment, personal equipment, office equipment, measurement equipment, industrial robots) under a normal operation and use condition.

The products are not designed or warranted to meet the requirements of the applications listed below, whose performance and/or quality require a more stringent level of safety or reliability, or whose failure, malfunction or trouble could cause serious damage to society, person or property.

When using the products for specific purposes, please first make confirmations in areas such as safety, reliability, and quality.

Please understand that we are not in a position to be held responsible for any damage or the like caused by any use exceeding the range or conditions of this specification sheet or by any use in the specific applications.

- | | |
|---|--|
| (1) Aerospace/Aviation equipment | (8) Public information-processing equipment |
| (2) Transportation equipment (electric trains, ships, etc.) | (9) Military equipment |
| (3) Medical equipment | (10) Electric heating apparatus, burning equipment |
| (4) Power-generation control equipment | (11) Disaster prevention/crime prevention equipment |
| (5) Atomic energy-related equipment | (12) Safety equipment |
| (6) Seabed equipment | (13) Other applications that are not considered general-purpose applications |
| (7) Transportation control equipment | |

When using this product in general-purpose standard applications, you are kindly requested to take into consideration securing protection circuit/equipment or providing backup circuits, etc to ensure higher safety.

Large Size Ferrite Cores for High Power

Product compatible with RoHS directive
Halogen-free

Overview of the T Series

FEATURES

- Large size cores for transformers with large power outputs.
- Can also be used in reactors.

APPLICATION

- Large size industrial equipment, transformers for consumer equipment
- Reactors

PART NUMBER CONSTRUCTION

| PE22 | T | 51 | × | 13 | × | 31 |
|----------|------------|------------------|-----------|-----------------|---|----|
| Material | Core shape | Outside Diameter | Thickness | Inside Diameter | | |
| PE22 | T | 51 | 13 | 31 | | |
| PC40 | | 62 | 20 | 39 | | |
| PC95 | | 72 | | 48 | | |
| PEL95 | | 80 | | 50 | | |
| PEM95 | | 96 | | 70 | | |
| | | 104 | | 80 | | |

RANGE OF USE AND STORAGE TEMPERATURE

| Temperature range | |
|----------------------------|--------------------------|
| Operating temperature (°C) | Storage temperature (°C) |
| -30 to +105 | -30 to +85 |

- RoHS Directive Compliant Product: See the following for more details. <https://product.tdk.com/info/en/environment/rohs/index.html>
- Halogen-free: Indicates that Cl content is less than 900ppm, Br content is less than 900ppm, and that the total Cl and Br content is less than 1500ppm.

Please be sure to request delivery specifications that provide further details on the features and specifications of the products for proper and safe use. Please note that the contents may change without any prior notice due to reasons such as upgrading.

Mn-Zn系 T Cores



SHAPES AND DIMENSIONS

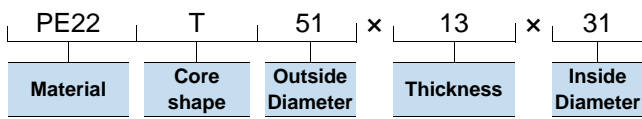
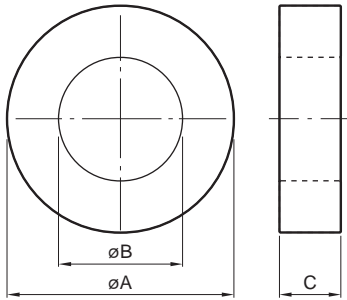

| Material | Part No. Shape Dimensions | Dimensions (mm) | | | Effective parameter Core factor | | Effective cross-sectional A_e (mm ²) | Effective magnetic path length L_e (mm) | Effective core volume V_e (mm ³) | Weigh (Approx.) (g) | Electrical characteristics AL-value (nH/N ²) 1kHz, 0.4A/m 23°C |
|----------|------------------------------|--------------------|----------|----------|------------------------------------|---|--|---|--|------------------------|--|
| | | ϕA | ϕB | ϕC | C_1 (mm ⁻¹) | $C_2 \times 10^{-2}$ (mm ⁻³) | | | | | |
| PE22 | T51x13x31 | 51.0±1.0 | 31.0±0.6 | 13.0±0.5 | 0.97084 | 0.76235 | 127 | 124 | 15740 | 80 | 2330±25% |
| PC40 | | | | | | | | | | | 2980±25% |
| PC95 | | | | | | | | | | | — |
| PEL95 | | | | | | | | | | | — |
| PEM95 | | | | | | | | | | | — |
| PE22 | T62x13x39 | 62.5±1.2 | 39.0±0.8 | 13.5±0.5 | 0.98689 | 0.63377 | 156 | 154 | 23930 | 121 | 2290±25% |
| PC40 | | | | | | | | | | | 2930±25% |
| PC95 | | | | | | | | | | | — |
| PEL95 | | | | | | | | | | | — |
| PEM95 | | | | | | | | | | | — |
| PE22 | T72x20x48 | 72.0±1.5 | 48.0±0.9 | 20.0±0.5 | 0.77481 | 0.32729 | 237 | 183 | 43420 | 217 | 2920±25% |
| PC40 | | | | | | | | | | | 3730±25% |
| PC95 | | | | | | | | | | | — |
| PEL95 | | | | | | | | | | | — |
| PEM95 | | | | | | | | | | | — |
| PE22 | T80x20x50 | 80.0±1.6 | 50.0±1.0 | 20.0±0.5 | 0.66842 | 0.22694 | 295 | 197 | 58990 | 294 | 3380±25% |
| PC40 | | | | | | | | | | | 4320±25% |
| PC95 | | | | | | | | | | | — |
| PEL95 | | | | | | | | | | | — |
| PEM95 | | | | | | | | | | | — |
| PE22 | T96x20x70 | 96.0±1.9 | 70±1.5 | 20.0±0.5 | 0.99464 | 0.38574 | 258 | 256 | 66130 | 325 | 2270±25% |
| PC40 | | | | | | | | | | | 2910±25% |
| PC95 | | | | | | | | | | | — |
| PEL95 | | | | | | | | | | | — |
| PEM95 | | | | | | | | | | | — |
| PE22 | T104x20x80 | 104.0±2.1 | 80 | 20.0±0.5 | 1.19742 | 0.50179 | 239 | 286 | 68180 | 333 | 1890±25% |
| PC40 | | | | | | | | | | | 2410±25% |
| PC95 | | | | | | | | | | | — |
| PEL95 | | | | | | | | | | | — |
| PEM95 | | | | | | | | | | | — |

⚠ Please be sure to request delivery specifications that provide further details on the features and specifications of the products for proper and safe use.
Please note that the contents may change without any prior notice due to reasons such as upgrading.

Mn-Zn

Large Size Ferrite Cores for High Power

UU series

 **REMINDERS FOR USING THESE PRODUCTS**

Please be sure to read this manual thoroughly before using the products.

The products listed on this catalog are intended for use in general electronic equipment (AV equipment, telecommunications equipment, home appliances, amusement equipment, computer equipment, personal equipment, office equipment, measurement equipment, industrial robots) under a normal operation and use condition.

The products are not designed or warranted to meet the requirements of the applications listed below, whose performance and/or quality require a more stringent level of safety or reliability, or whose failure, malfunction or trouble could cause serious damage to society, person or property.

When using the products for specific purposes, please first make confirmations in areas such as safety, reliability, and quality.

Please understand that we are not in a position to be held responsible for any damage or the like caused by any use exceeding the range or conditions of this specification sheet or by any use in the specific applications.

- | | |
|---|--|
| (1) Aerospace/Aviation equipment | (8) Public information-processing equipment |
| (2) Transportation equipment (electric trains, ships, etc.) | (9) Military equipment |
| (3) Medical equipment | (10) Electric heating apparatus, burning equipment |
| (4) Power-generation control equipment | (11) Disaster prevention/crime prevention equipment |
| (5) Atomic energy-related equipment | (12) Safety equipment |
| (6) Seabed equipment | (13) Other applications that are not considered general-purpose applications |
| (7) Transportation control equipment | |

When using this product in general-purpose standard applications, you are kindly requested to take into consideration securing protection circuit/equipment or providing backup circuits, etc to ensure higher safety.

Large Size Ferrite Cores for High Power

Product compatible with RoHS directive
Halogen-free

Overview of the UU Series

FEATURES

- Large size cores for transformers with large power outputs.
- Can also be used in reactors.

APPLICATION

- Large size industrial equipment, transformers for consumer equipment
- Reactors

PART NUMBER CONSTRUCTION

| PE22 | UU | 79 | x | 129 | x | 31 |
|----------|------------|-------|---|-----------------------|---|-----------|
| Material | Core shape | Width | | Height when assembled | | Thickness |
| PE22 | UU | 79 | | 115 | | 31 |
| PC40 | | 100 | | 129 | | 30 |
| PE90 | | 100 | | 150 | | 20 |
| PC95 | | 101 | | 160 | | 25 |
| PEL95 | | 120 | | | | 20 |
| PEM95 | | 80 | | | | 30N |
| | | | | | | 30N |
| | | | | | | 25N |

RANGE OF USE AND STORAGE TEMPERATURE

| Temperature range | |
|----------------------------|--------------------------|
| Operating temperature (°C) | Storage temperature (°C) |
| -30 to +105 | -30 to +85 |

- RoHS Directive Compliant Product: See the following for more details.<https://product.tdk.com/info/en/environment/rohs/index.html>
- Halogen-free: Indicates that Cl content is less than 900ppm, Br content is less than 900ppm, and that the total Cl and Br content is less than 1500ppm.

Please be sure to request delivery specifications that provide further details on the features and specifications of the products for proper and safe use. Please note that the contents may change without any prior notice due to reasons such as upgrading.

Mn-Zn UU Cores



SHAPES AND DIMENSIONS

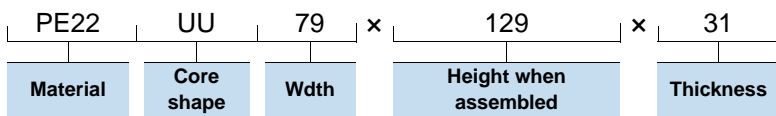
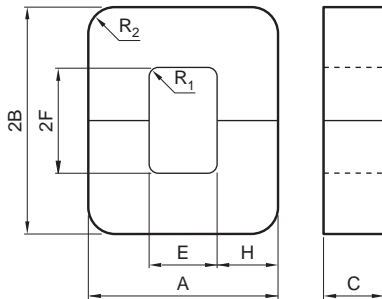

| Material | Part No. Shape Dimensions | Dimensions (mm) | | | | | | | | R1 | R2 | Ex2F(mm ²) |
|--|------------------------------|-----------------|-----------|----------|----------|-----------|----------|---|----|------|----|------------------------|
| | | A | 2B | C | E | 2F | H | | | | | |
| PE22 PC40 PC95 PEL95 PEM95 | UU79x129x31 | 79.0±2.5 | 129.0±2.5 | 31.5±1.0 | 34.0min. | 85.0±1.5 | 22.0±1.0 | 5 | 22 | 2980 | | |
| PE22 PC40 PC95 PEL95 PEM95 | UU100x151x30 | 100.0±3.0 | 151.0±2.5 | 30.0±1.0 | 39.0min. | 90.0±1.5 | 30.0±1.5 | 5 | 30 | 3600 | | |
| PE22 PC40 PC95 PEL95 PEM95 | UU101x115x25 | 101.0±3.0 | 115.0±2.5 | 25.4±1.0 | 50.0min. | 64.0±1.5 | 25.0±1.0 | 5 | 25 | 3260 | | |
| PE22 PC40 PC95 PEL95 PEM95 | UU120x160x20 | 120.0±3.0 | 160.0±2.5 | 20.0±1.0 | 59.0min. | 100.0±1.5 | 30.0±1.5 | 5 | 35 | 6000 | | |
| PE22 PC40 PC95 PEL95 PEM95 | UU80x150x30N | 80.0±3.0 | 150.0±2.5 | 30.0±1.0 | 39.0min. | 110.0±1.5 | 20.0±1.0 | 1 | 0 | 4400 | | |

⚠ Please be sure to request delivery specifications that provide further details on the features and specifications of the products for proper and safe use.
Please note that the contents may change without any prior notice due to reasons such as upgrading.

Mn-Zn UU Cores

| Material | Part No. Shape Dimensions | Effective parameter | | Effective cross-sectional area Ae (mm ²) | Effective magnetic path length Le (mm) | Effective core volume Ve (mm ³) | Weigh (Approx.) (g) | Electrical characteristics AL-value (nH/N ²) 1kHz, 0.4A/m 23 °C |
|----------|---------------------------------|---------------------------|--|--|--|---|------------------------|---|
| | | Core factor | | | | | | |
| | | C1 (mm ⁻¹) | C2 x 10 ⁻² (mm ⁻³) | | | | | |
| PE22 | UU79x129x31 | 0.44605 | 0.06437 | 693 | 309 | 214220 | 1080 | 4790±25% |
| PC40 | | | | | | | | 6030±25% |
| PC95 | | | | | | | | 8300 * |
| PEL95 | | | | | | | | 9600 * |
| PEM95 | | | | | | | | 7600 * |
| PE22 | UU100x151x30 | 0.38801 | 0.04241 | 915 | 355 | 324860 | 1630 | 5540±25% |
| PC40 | | | | | | | | 6990±25% |
| PC95 | | | | | | | | — |
| PEL95 | | | | | | | | — |
| PEM95 | | | | | | | | — |
| PE22 | UU101x115x25 | 0.47757 | 0.07373 | 648 | 309 | 200350 | 1000 | 4480±25% |
| PC40 | | | | | | | | 5640±25% |
| PC95 | | | | | | | | — |
| PEL95 | | | | | | | | — |
| PEM95 | | | | | | | | — |
| PE22 | UU120x160x20 | 0.69041 | 0.11507 | 600 | 414 | 248550 | 1240 | 3140±25% |
| PC40 | | | | | | | | 3960±25% |
| PC95 | | | | | | | | — |
| PEL95 | | | | | | | | — |
| PEM95 | | | | | | | | — |
| PE22 | UU80x150x30N | 0.60472 | 0.00101 | 600 | 363 | 217700 | 1095 | 3570±25% |
| PC40 | | | | | | | | 4500±25% |
| PC95 | | | | | | | | — |
| PEL95 | | | | | | | | — |
| PEM95 | | | | | | | | — |

* Typ. value for no specification tolerance

□ Core loss Temperature characteristics (Typ.)

UU79x129x31 at 25kHz,200mT

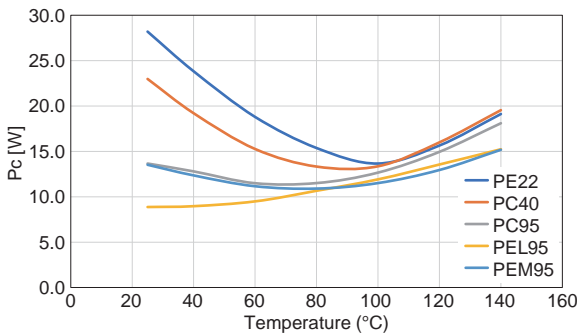

⚠ Please be sure to request delivery specifications that provide further details on the features and specifications of the products for proper and safe use. Please note that the contents may change without any prior notice due to reasons such as upgrading.

Mn-Zn UU series Part No.: PE22 UU79X129X31

SHAPES AND DIMENSIONS

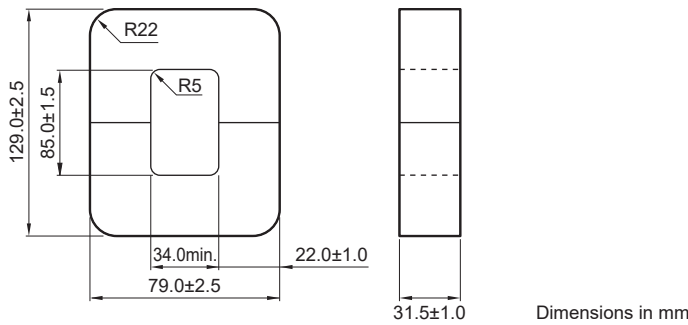

| Effective parameter | | | | | | | | Electrical characteristics |
|------------------------------|---|--------------------------------|--------------------------------|-----------------------------|------------------------------------|--------------------------------|-----------------|--|
| Core factor | | Effective magnetic path length | Effective cross-sectional area | Effective core volume | Minimum cross-sectional area | Winding cross-sectional area | Weigh (approx.) | AL-value |
| C_1 (mm ⁻¹) | $C_2 \times 10^{-2}$ (mm ⁻³) | l_e (mm) | A_e (mm ²) | V_e (mm ³) | $A_{min.}^*$ (mm ²) | A_{cw} (mm ²) | (g) | (nH/N ²) 1kHz 0.4A/m 23°C |
| 0.44605 | 0.06437 | 309 | 693 | 214220 | 693LB* | 2980 | 1080 | 4790±25% |

* The symbol followed A min. value shows minimum cross-sectional area part.
L is outer pole part, B is the back part.

NI limit vs. AL-value

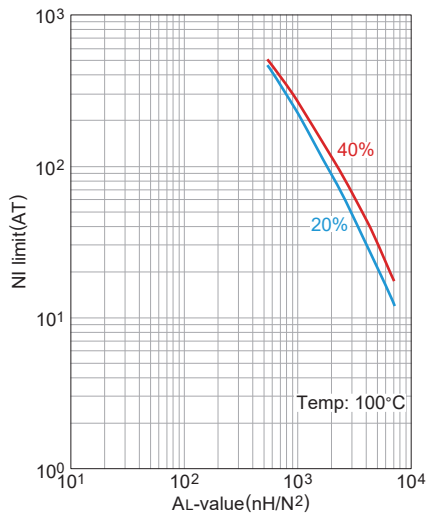

The 20% and 40% graph shows when a 20% and 40% drop from the initial AL-value has been made due to the DC superimposition.

AL-value vs. Air gap length

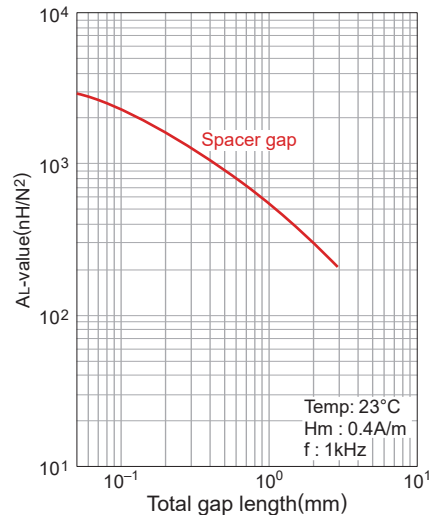

Mn-Zn UU series Part No.: PC40 UU79X129X31

SHAPES AND DIMENSIONS

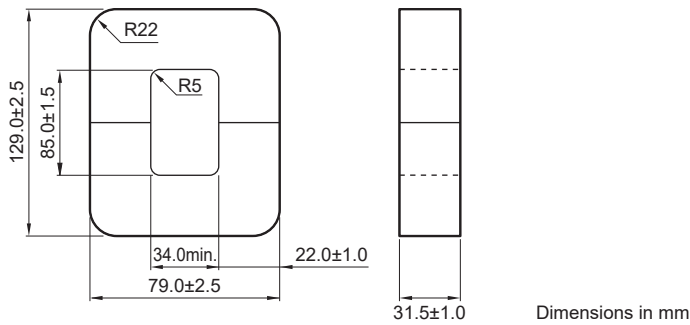

| Effective parameter | | | | | | | | Electrical characteristics |
|------------------------------|---|--------------------------------|--------------------------------|-----------------------------|------------------------------------|--------------------------------|-----------------|--|
| Core factor | | Effective magnetic path length | Effective cross-sectional area | Effective core volume | Minimum cross-sectional area | Winding cross-sectional area | Weigh (approx.) | AL-value |
| C_1 (mm ⁻¹) | $C_2 \times 10^{-2}$ (mm ⁻³) | l_e (mm) | A_e (mm ²) | V_e (mm ³) | $A_{min.}^*$ (mm ²) | A_{cw} (mm ²) | (g) | (nH/N ²) 1kHz 0.4A/m 23°C |
| 0.44605 | 0.06437 | 309 | 693 | 214220 | 693LB* | 2980 | 1080 | 6030±25% |

* The symbol followed A min. value shows minimum cross-sectional area part.
L is outer pole part, B is the back part.

NI limit vs. AL-value

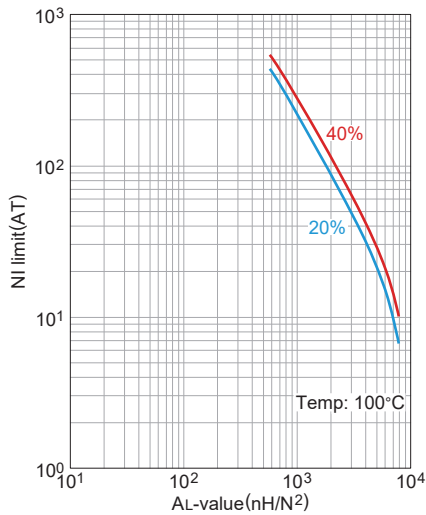

The 20% and 40% graph shows when a 20% and 40% drop from the initial AL-value has been made due to the DC superimposition.

AL-value vs. Air gap length

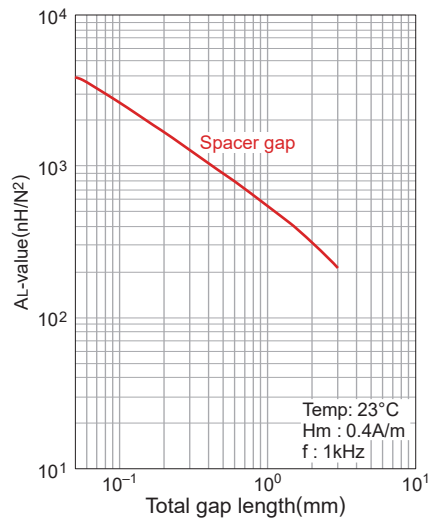

Mn-Zn UU series Part No.: PE22 UU100X151X30

SHAPES AND DIMENSIONS

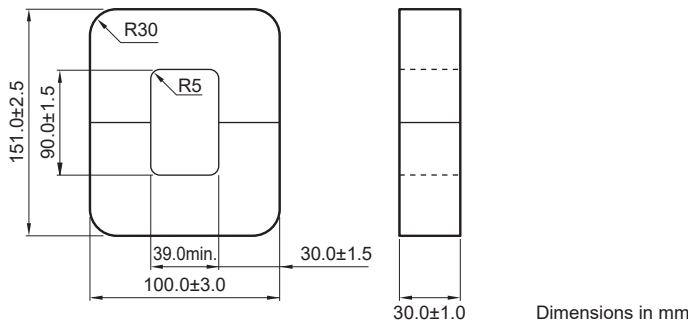

| Effective parameter | | | | | | | | Electrical characteristics |
|------------------------------|---|---|---|--|--|--|------------------------|--|
| Core factor | | Effective magnetic path length l_e (mm) | Effective cross-sectional area A_e (mm ²) | Effective core volume V_e (mm ³) | Minimum cross-sectional area $A_{min.}^*$ (mm ²) | Winding cross-sectional area A_{cw} (mm ²) | Weigh (approx.) (g) | AL-value (nH/N ²) 1kHz 0.4A/m 23°C |
| C_1 (mm ⁻¹) | $C_2 \times 10^{-2}$ (mm ⁻³) | | | | | | | |
| 0.38801 | 0.04241 | 355 | 915 | 324860 | 900L* | 3600 | 1630 | 5540±25% |

* The symbol followed A min. value shows minimum cross-sectional area part.
L is outer pole part, B is the back part.

NI limit vs. AL-value

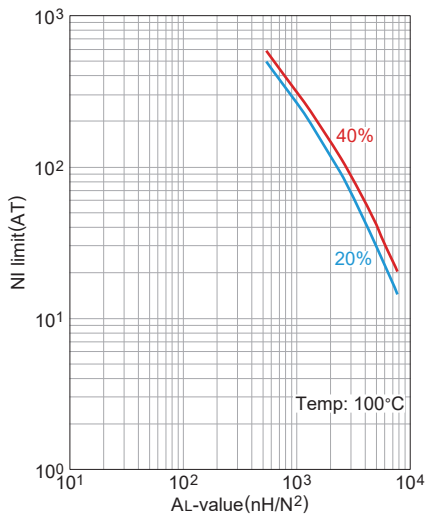

The 20% and 40% graph shows when a 20% and 40% drop from the initial AL-value has been made due to the DC superimposition.

AL-value vs. Air gap length

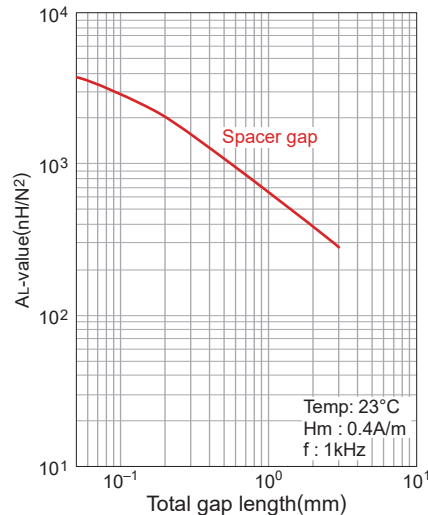

Mn-Zn UU series Part No.: PC40 UU100X151X30

SHAPES AND DIMENSIONS

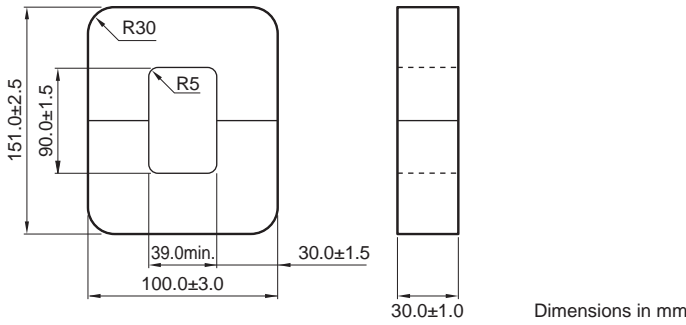

| Effective parameter | | | | | | | | Electrical characteristics |
|-------------------------------|--|--------------------------------|--------------------------------|----------------------------|---|-------------------------------|-----------------|--|
| Core factor | | Effective magnetic path length | Effective cross-sectional area | Effective core volume | Minimum cross-sectional area | Winding cross-sectional area | Weigh (approx.) | AL-value |
| C_1 (mm^{-1}) | $C_2 \times 10^{-2}$ (mm^{-3}) | l_e (mm) | A_e (mm^2) | V_e (mm^3) | $A \text{ min.}^*$ (mm^2) | A_{cw} (mm^2) | (g) | (nH/N^2) 1kHz 0.4A/m 23°C |
| 0.38801 | 0.04241 | 355 | 915 | 324860 | 900L* | 3600 | 1630 | 6990±25% |

* The symbol followed A min. value shows minimum cross-sectional area part.
L is outer pole part, B is the back part.

NI limit vs. AL-value

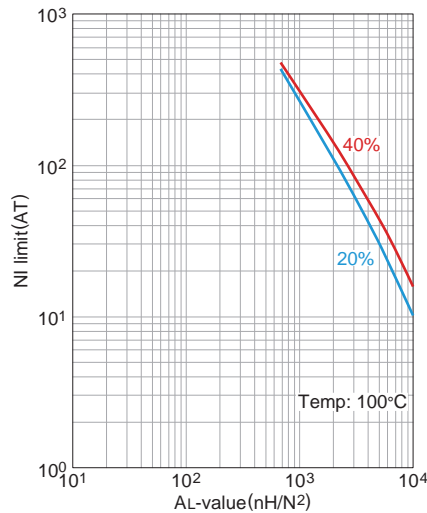

The 20% and 40% graph shows when a 20% and 40% drop from the initial AL-value has been made due to the DC superimposition.

AL-value vs. Air gap length

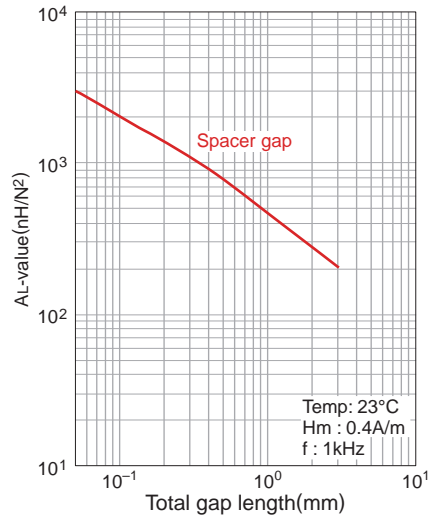

Mn-Zn UU series Part No.: PE22 UU101X115X25

SHAPES AND DIMENSIONS

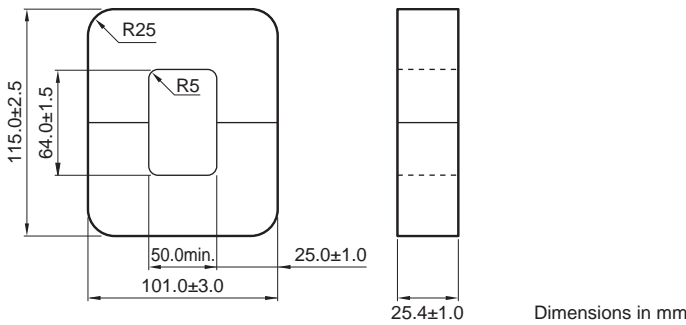

| Effective parameter | | | | | | | | Electrical characteristics |
|------------------------------|---|--------------------------------|--------------------------------|-----------------------------|------------------------------------|--------------------------------|-----------------|--|
| Core factor | | Effective magnetic path length | Effective cross-sectional area | Effective core volume | Minimum cross-sectional area | Winding cross-sectional area | Weigh (approx.) | AL-value |
| C_1 (mm ⁻¹) | $C_2 \times 10^{-2}$ (mm ⁻³) | l_e (mm) | A_e (mm ²) | V_e (mm ³) | $A_{min.}^*$ (mm ²) | A_{cw} (mm ²) | (g) | (nH/N ²) 1kHz 0.4A/m 23°C |
| 0.47757 | 0.07373 | 309 | 648 | 200350 | 635L* | 3260 | 1000 | 4480±25% |

* The symbol followed A min. value shows minimum cross-sectional area part.
L is outer pole part, B is the back part.

NI limit vs. AL-value

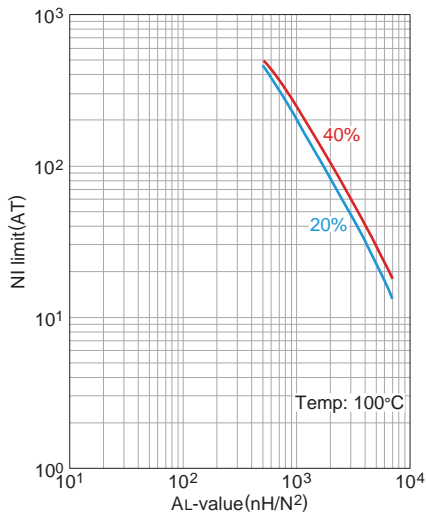

The 20% and 40% graph shows when a 20% and 40% drop from the initial AL-value has been made due to the DC superimposition.

AL-value vs. Air gap length

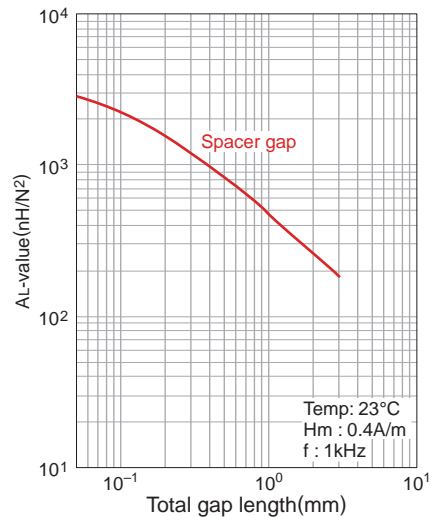

Mn-Zn UU series Part No.: PC40 UU101X115X25

SHAPES AND DIMENSIONS

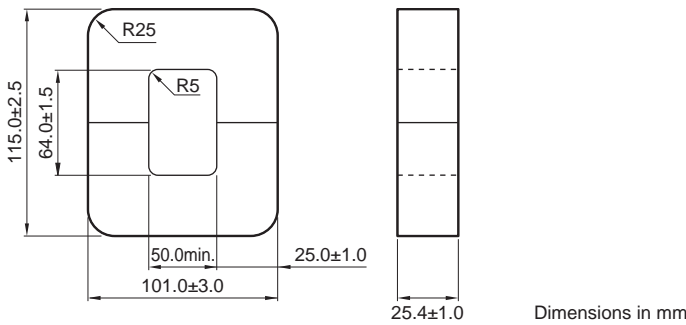

| Effective parameter | | | | | | | | Electrical characteristics |
|------------------------------|---|--------------------------------|--------------------------------|-----------------------------|------------------------------------|--------------------------------|-----------------|--|
| Core factor | | Effective magnetic path length | Effective cross-sectional area | Effective core volume | Minimum cross-sectional area | Winding cross-sectional area | Weigh (approx.) | AL-value |
| C_1 (mm ⁻¹) | $C_2 \times 10^{-2}$ (mm ⁻³) | l_e (mm) | A_e (mm ²) | V_e (mm ³) | $A_{min.}^*$ (mm ²) | A_{cw} (mm ²) | (g) | (nH/N ²) 1kHz 0.4A/m 23°C |
| 0.47757 | 0.07373 | 309 | 648 | 200350 | 635L* | 3260 | 1000 | 5640±25% |

* The symbol followed A min. value shows minimum cross-sectional area part.
L is outer pole part, B is the back part.

NI limit vs. AL-value

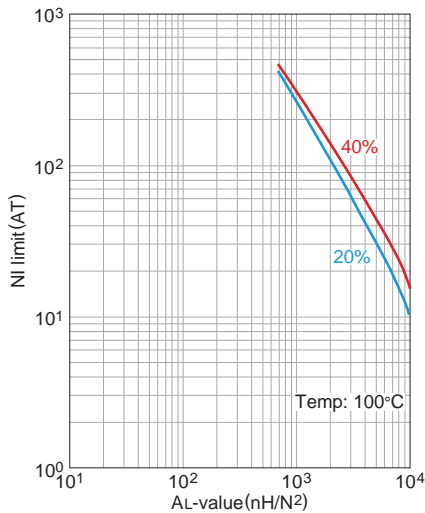

The 20% and 40% graph shows when a 20% and 40% drop from the initial AL-value has been made due to the DC superimposition.

AL-value vs. Air gap length

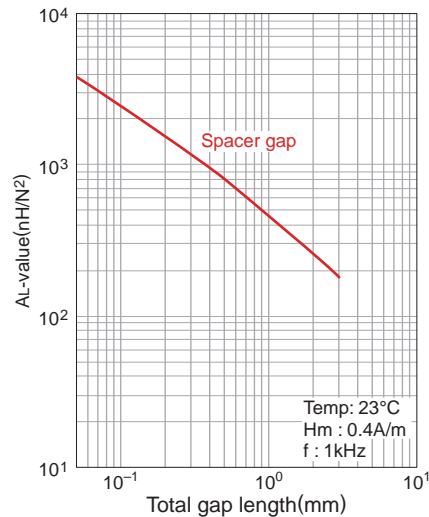

Mn-Zn UU series Part No.: PE22 UU120X160X20

SHAPES AND DIMENSIONS

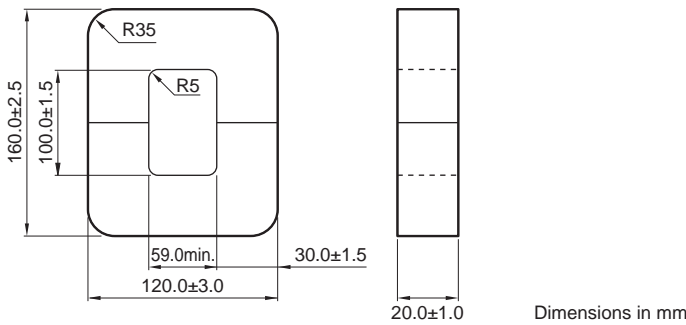

| Effective parameter | | | | | | | | Electrical characteristics |
|---------------------------------------|---|--------------------------------|--------------------------------------|--------------------------------------|-------------------------------|---------------------------------------|-----------------|--|
| Core factor | | Effective magnetic path length | Effective cross-sectional area | Effective core volume | Minimum cross-sectional area | Winding cross-sectional area | Weigh (approx.) | AL-value |
| C ₁ (mm ⁻¹) | C ₂ ×10 ⁻² (mm ⁻³) | ℓ _e (mm) | A _e (mm ²) | V _e (mm ³) | A min.* (mm ²) | A _{cw} (mm ²) | (g) | (nH/N ²) 1kHz 0.4A/m 23°C |
| 0.69041 | 0.11507 | 414 | 600 | 248550 | 600LB* | 6000 | 1240 | 3140±25% |

* The symbol followed A min. value shows minimum cross-sectional area part.
L is outer pole part, B is the back part.

NI limit vs. AL-value

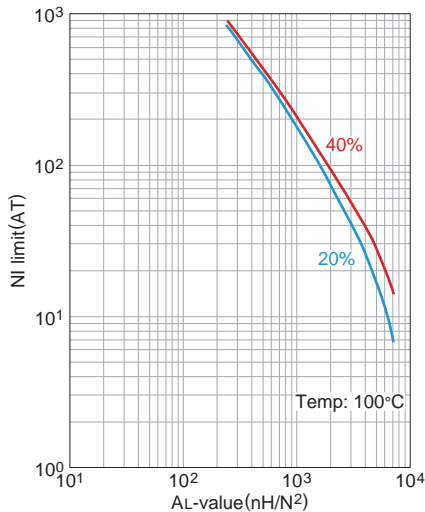

The 20% and 40% graph shows when a 20% and 40% drop from the initial AL-value has been made due to the DC superimposition.

AL-value vs. Air gap length

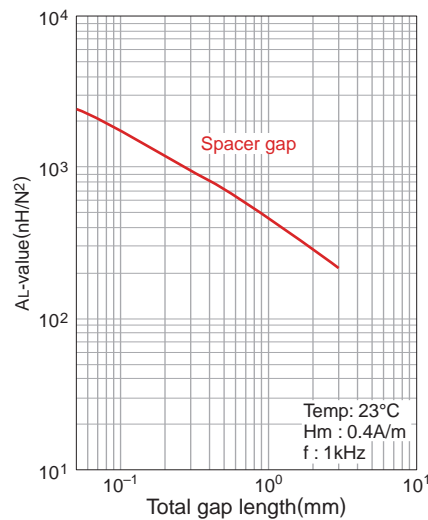

Mn-Zn UU series Part No.: PC40 UU120X160X20

SHAPES AND DIMENSIONS

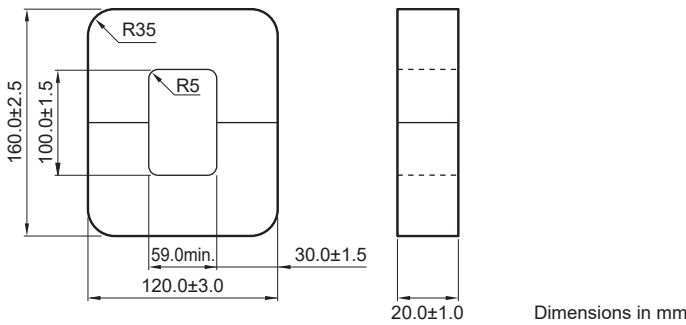

| Effective parameter | | | | | | | | Electrical characteristics |
|------------------------------|---|--------------------------------|--------------------------------|-----------------------------|------------------------------------|--------------------------------|-----------------|--|
| Core factor | | Effective magnetic path length | Effective cross-sectional area | Effective core volume | Minimum cross-sectional area | Winding cross-sectional area | Weigh (approx.) | AL-value |
| C_1 (mm ⁻¹) | $C_2 \times 10^{-2}$ (mm ⁻³) | l_e (mm) | A_e (mm ²) | V_e (mm ³) | $A_{min.}^*$ (mm ²) | A_{cw} (mm ²) | (g) | (nH/N ²) 1kHz 0.4A/m 23°C |
| 0.69041 | 0.11507 | 414 | 600 | 248550 | 600LB* | 6000 | 1240 | 3960±25% |

* The symbol followed A min. value shows minimum cross-sectional area part.
L is outer pole part, B is the back part.

NI limit vs. AL-value

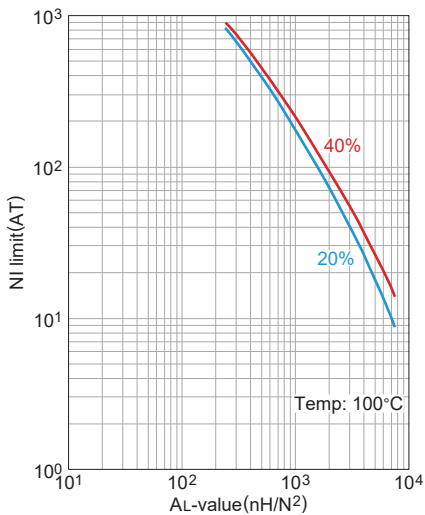

The 20% and 40% graph shows when a 20% and 40% drop from the initial AL-value has been made due to the DC superimposition.

AL-value vs. Air gap length

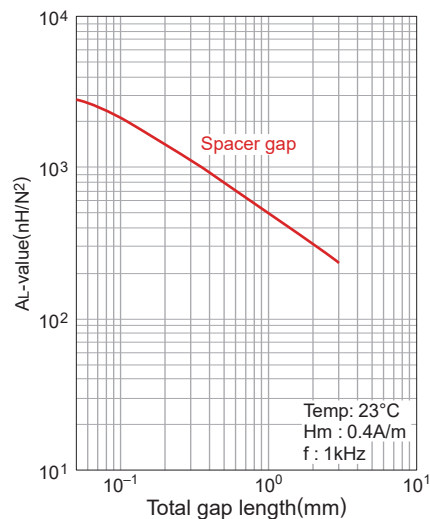

⚠ Please be sure to request delivery specifications that provide further details on the features and specifications of the products for proper and safe use.
Please note that the contents may change without any prior notice due to reasons such as upgrading.

Ni-Zn

Ferrites for EMI Suppression

RID series(Multi-aperture Type)

**REMINDERS FOR USING THESE PRODUCTS**

Please be sure to read this manual thoroughly before using the products.

The products listed on this catalog are intended for use in general electronic equipment (AV equipment, telecommunications equipment, home appliances, amusement equipment, computer equipment, personal equipment, office equipment, measurement equipment, industrial robots) under a normal operation and use condition.

The products are not designed or warranted to meet the requirements of the applications listed below, whose performance and/or quality require a more stringent level of safety or reliability, or whose failure, malfunction or trouble could cause serious damage to society, person or property.

When using the products for specific purposes, please first make confirmations in areas such as safety, reliability, and quality.

Please understand that we are not in a position to be held responsible for any damage or the like caused by any use exceeding the range or conditions of this specification sheet or by any use in the specific applications.

- | | |
|---|--|
| (1) Aerospace/Aviation equipment | (8) Public information-processing equipment |
| (2) Transportation equipment (electric trains, ships, etc.) | (9) Military equipment |
| (3) Medical equipment | (10) Electric heating apparatus, burning equipment |
| (4) Power-generation control equipment | (11) Disaster prevention/crime prevention equipment |
| (5) Atomic energy-related equipment | (12) Safety equipment |
| (6) Seabed equipment | (13) Other applications that are not considered general-purpose applications |
| (7) Transportation control equipment | |

When using this product in general-purpose standard applications, you are kindly requested to take into consideration securing protection circuit/equipment or providing backup circuits, etc to ensure higher safety.

Ferrites for EMI Suppression

Product compatible with RoHS directive
Halogen-free

Overview of the RID Series

■ PART NUMBER CONSTRUCTION

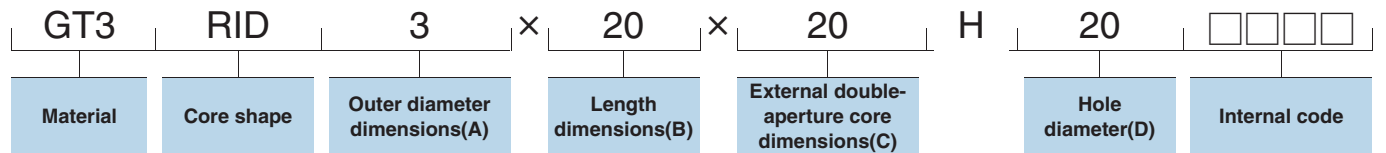

•Please consult us about the size of the details separately.

■ RANGE OF USE AND STORAGE TEMPERATURE

| Temperature range* | |
|----------------------------|----------------------------|
| Operating temperature (°C) | Storage temperature** (°C) |
| -40 to +85 | -40 to +85 |

* The temperature range has a different case by materials.

** The Storage temperature range is for after the circuit board is mounted.

○ RoHS Directive Compliant Product: See the following for more details related to RoHS Directive compliant products. <http://www.tdk.co.jp/rohs/>

○ Halogen-free: Indicates that Cl content is less than 900ppm, Br content is less than 900ppm, and that the total Cl and Br content is less than 1500ppm.

• All specifications are subject to change without notice.

Ni-Zn RID series(Standard Type)



SHAPES AND DIMENSIONS

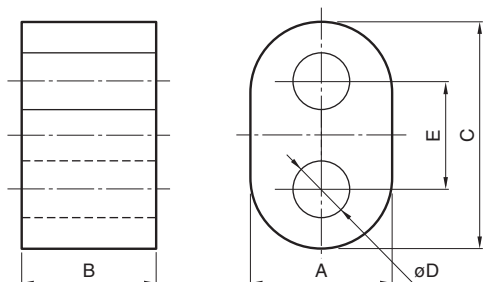

| Shapes | Dimensions (mm) | | | | |
|------------------|-----------------|----------|----------|----------|-----|
| | A | B | C | øD | E |
| RID1.9X2X3.4H0.9 | 1.9±0.1 | 2.0±0.15 | 3.4±0.3 | 0.9±0.1 | 1.4 |
| RID2.6X4X5.1H1.4 | 2.6±0.3 | 4.0±0.3 | 5.1±0.3 | 1.4±0.2 | 2.5 |
| RID3X2X5H1.2 | 3.0±0.2 | 2.0±0.2 | 5.2±0.3 | 1.2±0.1 | 2.6 |
| RID3X3X5H1.2 | 3.0±0.2 | 3.0±0.2 | 5.2±0.3 | 1.2±0.1 | 2.6 |
| RID3X5X5H1.2 | 3.0±0.2 | 5.0±0.2 | 5.2±0.3 | 1.2±0.1 | 2.6 |
| RID6.5X4X12H3.8 | 6.5±0.3 | 4.0±0.3 | 12.0±0.5 | 3.8±0.25 | 5.5 |
| RID7.5X7X13H3.8 | 7.5±0.3 | 7.0±0.3 | 13.3±0.5 | 3.8±0.25 | 5.8 |
| RID8X7X15H5 | 8.0±0.3 | 7.0±0.3 | 15.0±0.5 | 5.0±0.25 | 7 |
| RID8X14X15H5T | 8.0±0.3 | 14.0±0.5 | 15.0±0.5 | 5.0±0.25 | 7 |

• Please refer to our individual catalog about the size and the characteristic, etc.

Ni-Zn
Mn-Zn
Ferrites for EMI suppression



T series (Ring-shape)



FEATURES

- Select various materials according to the noise frequency.
- The product has a wide range of sizes ranging from $\phi 14$ to $\phi 104$ outer diameters.
- Epoxy coating is also available. (HF60 and HF90 only)

APPLICATION

- Imaging devices, audio equipment, automotive electronics, communication devices, office electronics, industrial equipment, other
- Absorption EMI and penetrating noise
 - Prevent parasitic oscillation

PART NUMBER CONSTRUCTION

For general use

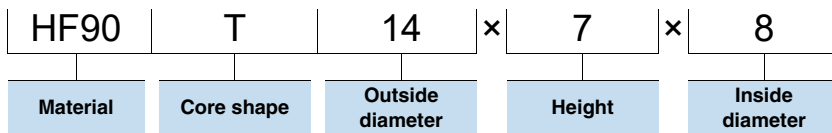

RANGE OF USE AND STORAGE TEMPERATURE

Ni-Zn T series (HF70)

| Temperature range* | |
|-------------------------------|-----------------------------|
| Operating temperature (°C) | Storage temperature (°C) |
| -40 to +85 | -40 to +85 |

Mn-Zn T series (HF60, HF90)

| Temperature range* | |
|-------------------------------|-----------------------------|
| Operating temperature (°C) | Storage temperature (°C) |
| -30 to +85 | -30 to +85 |

* If you want to use or store the product above this temperature, please contact us.

T series (Ring-shape)

SHAPE & DIMENSIONS

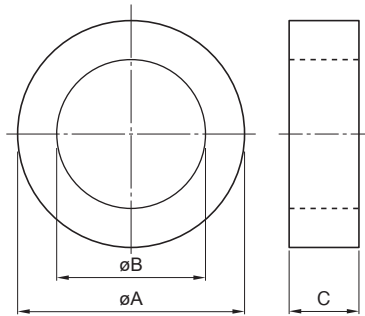

Ni-Zn T series (HF70)

| Shape | Material | Dimensions | | | Impedance (Ω) min. | | | | Part No. |
|-----------|----------|------------|----------|----------|--------------------|------|--------------|---------------|-------------------------------|
| | | ØA (mm) | ØB (mm) | C (mm) | 0.5MHz | 1MHz | 10MHz (n=1T) | 100MHz (n=1T) | |
| T14X7X8 | HF70 | 14.0±0.3 | 8.0±0.3 | 7.0±0.2 | — | — | 24 | 51 | HF70T14X7X8 |
| T18X10X10 | HF70 | 18.0±0.3 | 10.0±0.3 | 10.0±0.3 | — | — | 32 | 62 | HF70T18X10X10 |
| T22X10X14 | HF70 | 22.0±0.4 | 14.0±0.3 | 10.0±0.3 | — | — | 25 | 50 | HF70T22X10X14 |
| T25X13X15 | HF70 | 25.0±0.3 | 15.0±0.3 | 13.0±0.2 | — | — | 33 | 68 | HF70T25X13X15 |
| T28X13X16 | HF70 | 28.0±0.4 | 16.0±0.4 | 13.0±0.3 | — | — | 41 | 83 | HF70T28X13X16 |
| T31X13X19 | HF70 | 31.0±0.5 | 19.0±0.5 | 13.0±0.2 | — | — | 37 | 75 | HF70T31X13X19 |

Mn-Zn T series (HF60)

| Shape | Material | Dimensions | | | Impedance (Ω) min. | | | | Part No. |
|-------------|----------|------------|----------|----------|--------------------|-------------|--------------|--------|---------------------------------|
| | | ØA (mm) | ØB (mm) | C (mm) | 0.5MHz (n=1T) | 1MHz (n=1T) | 10MHz (n=1T) | 100MHz | |
| T14X7X8 | HF60 | 14.0±0.5 | 8.0±0.5 | 7.0±0.5 | — | 3.12 | 15.02 | — | HF60T14X7X8 |
| T18X10X10 | HF60 | 18.0±0.7 | 10.0±0.7 | 10.0±0.5 | — | 4.67 | 22.50 | — | HF60T18X10X10 |
| T22X10X14 | HF60 | 22.0±0.7 | 14.0±0.7 | 10.0±0.5 | — | 3.60 | 17.30 | — | HF60T22X10X14 |
| T25X13X15 | HF60 | 25.0±1.0 | 15.0±1.0 | 13.0±1.0 | — | 5.29 | 25.48 | — | HF60T25X13X15 |
| T28X13X16 | HF60 | 28.0±1.0 | 16.0±1.0 | 13.0±1.0 | — | 5.79 | 27.89 | — | HF60T28X13X16 |
| T31X13X19 | HF60 | 31.0±1.0 | 19.0±1.0 | 13.0±1.0 | — | 5.07 | 24.42 | — | HF60T31X13X19 |
| T38X14X22 | HF60 | 38.0±1.0 | 22.0±1.0 | 14.0±1.0 | — | 6.10 | 29.30 | — | HF60T38X14X22 |
| T44.5X13X30 | HF60 | 44.5±1.0 | 30.0±1.0 | 13.0±1.0 | — | 4.10 | 20.00 | — | HF60T44.5X13X30 |
| T62X13X39 | HF60 | 62.5±1.3 | 39.0±1.3 | 13.5±1.0 | — | 5.40 | 27.00 | — | HF60T62X13X39 |
| T80X20X50 | HF60 | 80.0±1.6 | 50.0±1.6 | 20.0±1.0 | — | 7.50 | 33.00 | — | HF60T80X20X50 |
| T104X20X80 | HF60 | 104.0±2.0 | 80.0±2.0 | 20.0±1.0 | — | 4.60* | 25.00* | — | HF60T104X20X80 |

* Reference value.

Mn-Zn T series (HF90)

| Shape | Material | Dimensions | | | Impedance (Ω) min. | | | | Part No. |
|-------------|----------|------------|----------|----------|--------------------|-------------|--------------|--------|---------------------------------|
| | | ØA (mm) | ØB (mm) | C (mm) | 0.5MHz (n=1T) | 1MHz (n=1T) | 10MHz (n=1T) | 100MHz | |
| T14X7X8 | HF90 | 14.0±0.3 | 8.0±0.3 | 7.0±0.2 | 15.5* | — | — | — | HF90T14X7X8 |
| T18X10X10 | HF90 | 18.0±0.3 | 10.0±0.3 | 10.0±0.3 | 22.4* | — | — | — | HF90T18X10X10 |
| T22X10X14 | HF90 | 22.0±0.4 | 14.0±0.3 | 10.0±0.3 | 18.9* | — | — | — | HF90T22X10X14 |
| T25X13X15 | HF90 | 25.0±0.3 | 15.0±0.3 | 13.0±0.3 | 22.2* | — | — | — | HF90T25X13X15 |
| T28X13X16 | HF90 | 28.0±0.4 | 16.0±0.4 | 13.0±0.3 | 18.8 | — | — | — | HF90T28X13X16 |
| T31X13X19 | HF90 | 31.0±0.5 | 19.0±0.4 | 13.0±0.3 | 14.4 | — | — | — | HF90T31X13X19 |
| T38X14X22 | HF90 | 38.0±0.8 | 22.0±0.5 | 14.0±0.3 | 15.4 | — | — | — | HF90T38X14X22 |
| T44.5X13X30 | HF90 | 44.5±1.1 | 30.0±0.8 | 13.0±0.5 | 12.5 | — | — | — | HF90T44.5X13X30 |
| T62X13X39 | HF90 | 62.5±1.3 | 39.0±0.8 | 13.5±0.5 | 8.3 | — | — | — | HF90T62X13X39 |
| T80X20X50 | HF90 | 80.0±1.6 | 50.0±1.0 | 20.0±0.5 | 8.2 | — | — | — | HF90T80X20X50 |
| T104X20X80 | HF90 | 104.0±2.0 | 80.0±1.6 | 20.0±0.5 | 5.9 | — | — | — | HF90T104X20X80 |

* Reference value.

⚠ Please be sure to request delivery specifications that provide further details on the features and specifications of the products for proper and safe use.
Please note that the contents may change without any prior notice due to reasons such as upgrading.

T series (Ring-shape)

ELECTRICAL CHARACTERISTICS

IMPEDANCE VS. FREQUENCY CHARACTERISTICS

T14X7X8

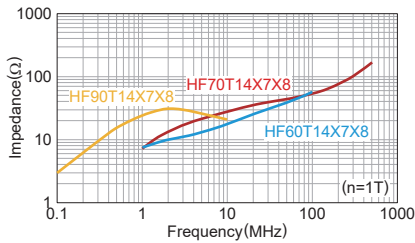

T18X10X10

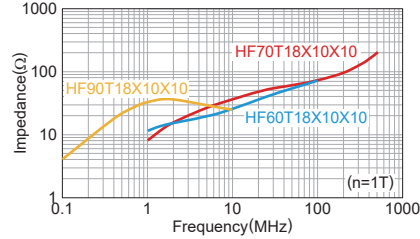

T22X10X14

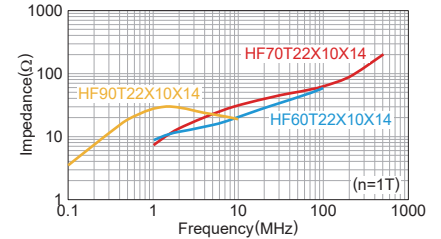

T25X13X15

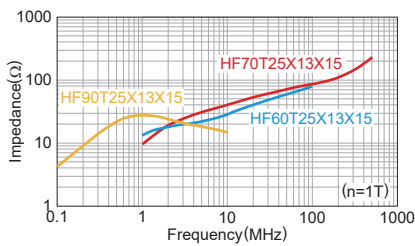

T28X13X16

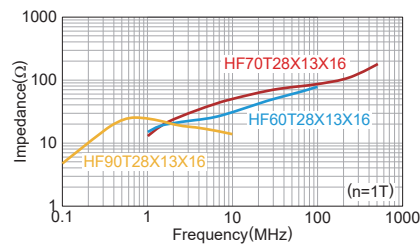

T31X13X19

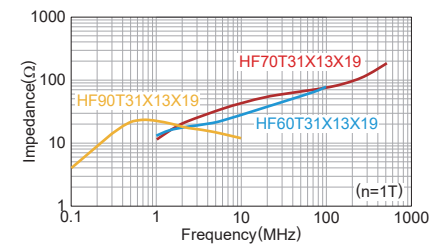

T38X14X22

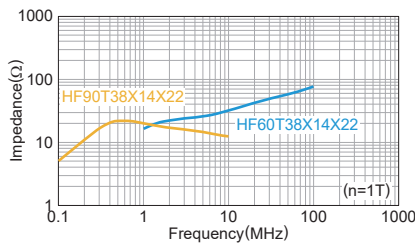

T44.5X13X30

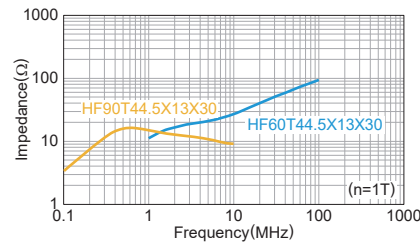

T62X13X39

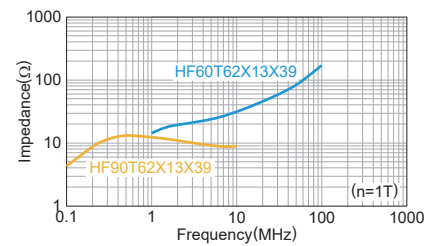

T80X20X50

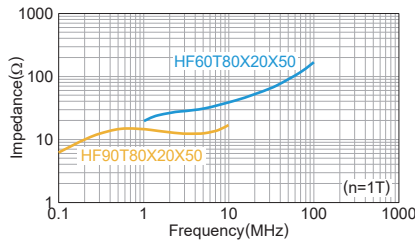

T104X20X80

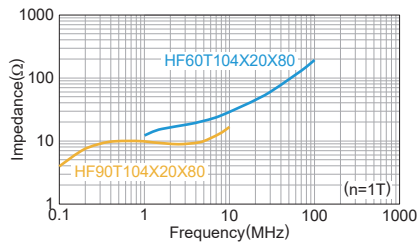

⚠ Please be sure to request delivery specifications that provide further details on the features and specifications of the products for proper and safe use. Please note that the contents may change without any prior notice due to reasons such as upgrading.

 **REMINDERS FOR USING THESE PRODUCTS**

Please be sure to read this manual thoroughly before using the products.

The products listed on this catalog are intended for use in general electronic equipment (AV equipment, telecommunications equipment, home appliances, amusement equipment, computer equipment, personal equipment, office equipment, measurement equipment, industrial robots) under a normal operation and use condition.

The products are not designed or warranted to meet the requirements of the applications listed below, whose performance and/or quality require a more stringent level of safety or reliability, or whose failure, malfunction or trouble could cause serious damage to society, person or property.

When using the products for specific purposes, please first make confirmations in areas such as safety, reliability, and quality.

Please note that we shall not be held responsible in any way if any damages should occur due to exceeding the scope or conditions of this manual, or through specific use these products.

- | | |
|---|--|
| (1) Aerospace/aviation equipment | (9) Military equipment |
| (2) Transportation equipment (cars, electric trains, ships, etc.) | (10) Electric heating apparatus, burning equipment |
| (3) Medical equipment | (11) Disaster prevention/crime prevention equipment |
| (4) Power-generation control equipment | (12) Safety equipment |
| (5) Atomic energy-related equipment | (13) Other applications that are not considered general-purpose applications |
| (6) Seabed equipment | |
| (7) Transportation control equipment | |
| (8) Public information-processing equipment | |

When using these products in general purposes and standard use, it is recommended that protection circuits are used, devices are secured, and backup circuits are kept for increased safety.

Ferrites for EMI suppressio

Sample Kits

We provides five kinds of ferrite core sample kits for EMC measurement in your design room or anechoic chamber. Please refer to our individual catalog about the size and the characteristic, etc. For more details, please contact us.

[EMC-A204 \(Mn-Zn\)](#)



[EMC-A205 \(Mn-Zn\)](#)

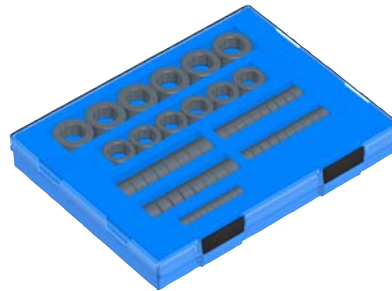

[EMC-A206 \(Mn-Zn\)](#)

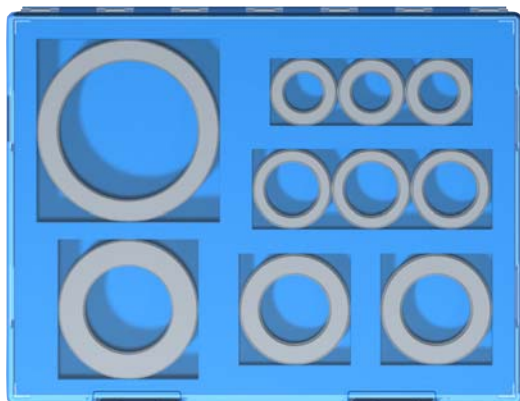

Mn-Zn Sample Kits **EMC-A204**

| Part No. | Number(pieces) |
|---------------------------------|----------------|
| HF90T38X14X22 | 3 |
| HF90T44.5X13X30 | 3 |
| HF90T62X13X39 | 2 |
| HF90T80X20X50 | 1 |
| HF90T104X20X80 | 1 |

• Please refer to our individual catalog about the size and the characteristic, etc.

 Please be sure to request delivery specifications that provide further details on the features and specifications of the products for proper and safe use.
Please note that the contents may change without any prior notice due to reasons such as upgrading.

20200731

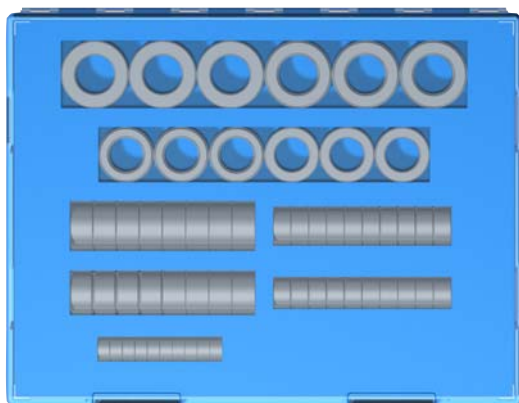
Mn-Zn Sample Kits **EMC-A205**

| Part No. | Number(pieces) |
|-------------------------------|----------------|
| HF60T14X7X8 | 5 |
| HF60T18X10X10 | 5 |
| HF60T22X10X14 | 5 |
| HF60T25X13X15 | 4 |
| HF60T28X13X16 | 4 |
| HF60T31X13X19 | 3 |
| HF60T38X14X22 | 3 |
| HF90T14X7X8 | 5 |
| HF90T18X10X10 | 5 |
| HF90T22X10X14 | 5 |
| HF90T25X13X15 | 4 |
| HF90T28X13X16 | 4 |
| HF90T31X13X19 | 3 |
| HF90T38X14X22 | 3 |

• Please refer to our individual catalog about the size and the characteristic, etc.

 Please be sure to request delivery specifications that provide further details on the features and specifications of the products for proper and safe use.
Please note that the contents may change without any prior notice due to reasons such as upgrading.

20200731

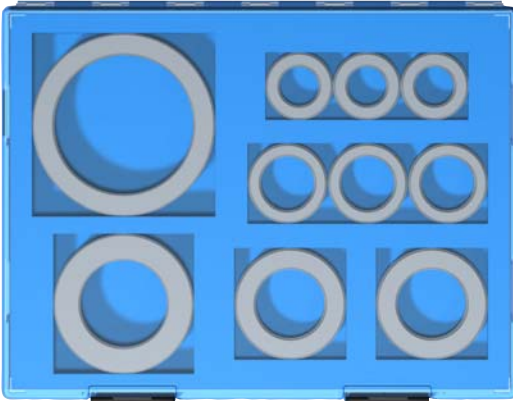
Mn-Zn Sample Kits, **EMC-A206**

| Part No. | Number(pieces) |
|---------------------------------|----------------|
| HF60T38X14X22 | 3 |
| HF60T44.5X13X30 | 3 |
| HF60T62X13X39 | 2 |
| HF60T80X20X50 | 1 |
| HF60T104X20X80 | 1 |

• Please refer to our individual catalog about the size and the characteristic, etc.

⚠ Please be sure to request delivery specifications that provide further details on the features and specifications of the products for proper and safe use.
Please note that the contents may change without any prior notice due to reasons such as upgrading.

20200731

 **REMINDERS FOR USING THESE PRODUCTS**

Please be sure to read this manual thoroughly before using the products.

The products listed on this catalog are intended for use in general electronic equipment (AV equipment, telecommunications equipment, home appliances, amusement equipment, computer equipment, personal equipment, office equipment, measurement equipment, industrial robots) under a normal operation and use condition.

The products are not designed or warranted to meet the requirements of the applications listed below, whose performance and/or quality require a more stringent level of safety or reliability, or whose failure, malfunction or trouble could cause serious damage to society, person or property.

When using the products for specific purposes, please first make confirmations in areas such as safety, reliability, and quality.

Please understand that we are not in a position to be held responsible for any damage or the like caused by any use exceeding the range or conditions of this specification sheet or by any use in the specific applications.

- | | |
|---|--|
| (1) Aerospace/Aviation equipment | (8) Public information-processing equipment |
| (2) Transportation equipment (electric trains, ships, etc.) | (9) Military equipment |
| (3) Medical equipment | (10) Electric heating apparatus, burning equipment |
| (4) Power-generation control equipment | (11) Disaster prevention/crime prevention equipment |
| (5) Atomic energy-related equipment | (12) Safety equipment |
| (6) Seabed equipment | (13) Other applications that are not considered general-purpose applications |
| (7) Transportation control equipment | |

When using this product in general-purpose standard applications, you are kindly requested to take into consideration securing protection circuit/equipment or providing backup circuits, etc to ensure higher safety.

Ferrite

Summary

 **REMINDERS FOR USING THESE PRODUCTS**

Please be sure to read this manual thoroughly before using the products.

The products listed on this catalog are intended for use in general electronic equipment (AV equipment, telecommunications equipment, home appliances, amusement equipment, computer equipment, personal equipment, office equipment, measurement equipment, industrial robots) under a normal operation and use condition.

The products are not designed or warranted to meet the requirements of the applications listed below, whose performance and/or quality require a more stringent level of safety or reliability, or whose failure, malfunction or trouble could cause serious damage to society, person or property.

Please understand that we are not responsible for any damage or liability caused by use of the products in any of the applications below or for any other use exceeding the range or conditions set forth in this specification sheet.

If you intend to use the products in the applications listed below or if you have special requirements exceeding the range or conditions set forth in the each catalog, please contact us.

- | | |
|---|--|
| (1) Aerospace/Aviation equipment | (9) Military equipment |
| (2) Transportation equipment (electric trains, ships, etc.) | (10) Electric heating apparatus, burning equipment |
| (3) Medical equipment | (11) Disaster prevention/crime prevention equipment |
| (4) Power-generation control equipment | (12) Safety equipment |
| (5) Atomic energy-related equipment | (13) Other applications that are not considered general-purpose applications |
| (6) Seabed equipment | |
| (7) Transportation control equipment | |
| (8) Public information-processing equipment | |

When using this product in general-purpose standard applications, you are kindly requested to take into consideration securing protection circuit/equipment or providing backup circuits, etc to ensure higher safety.

Overview of the Ferrite

Ferrite is a polycrystal, sintered material with high electrical resistivity. The high resistance of ferrite makes eddy current losses extremely low at high frequencies. Therefore, unlike other magnetic components, ferrite can be used at considerably high frequencies. Manganese-zinc (Mn-Zn) ferrites can be used at frequencies up to several megahertz.

The basic ferrite materials are obtained in an extremely high purity. These materials are mixed, calcined, milled, granulated, formed by pressing, and sintered at a temperature of 1000°C to 1400°C, then machined. The electrical and mechanical properties of a particular ferrite material are obtained by the material formulation and the processing applied. Extraordinary exacting process controls are required to assure the high uniformity of product for which TDK ferrites are well known. Through the above processes, ferrite materials can be optimized for specific applications.

Each of these materials can be produced in cores of various shapes. Shapes which are popular for the listed applications are:

APPLICATIONS, CHARACTERISTICS AND TDK CORE TYPE

| Applications | Ferrite characteristics | TDK core type |
|-------------------------------|---|---------------------|
| Filters | Low loss, magnetic stability, high permeability | RM cores |
| Signal transformers | High saturation flux density, high permeability | EP, EE and RM cores |
| Power conversion transformers | High saturation flux density, low power loss | EI, EC and RM cores |

TDK produces a very large variety of cores and magnetic properties. Nearly every requirement can be satisfied among these products.

TYPICAL TECHNICAL DATA

| | |
|--------------------------------------|--|
| Specific heat | 800(J/kg • K) |
| Thermal conductivity | 1 to 5(W/m • K) |
| Linear thermal expansion coefficient | 1.2×10^{-5} (1/K) |
| Vickers hardness | 550 |
| Tensile strength | 2 to 5×10^7 (N/m ²) |
| Bending strength(50mm span) | 9.8×10^7 (N/m ²) |
| Young's modulus | 1.2×10^{11} (N/m ²) |

• These values are typical at room temperature.

○ RoHS Directive Compliant Product: See the following for more details related to RoHS Directive compliant products. <http://www.tdk.co.jp/rohs/>

○ Halogen-free: Indicates that Cl content is less than 900ppm, Br content is less than 900ppm, and that the total Cl and Br content is less than 1500ppm.

 Please be sure to request delivery specifications that provide further details on the features and specifications of the products for proper and safe use. Please note that the contents may change without any prior notice due to reasons such as upgrading.

Terms Definitions and Explanations

1. PERMEABILITY

1.1 INITIAL PERMEABILITY, μ_i

The initial permeability of a material is determined by the following formula, on the basis of the effective self-inductance exhibited by a test coil for a low AC magnetic field induced (approx.: 0.4A/m max.) in the toroidal core which is made of that material and on which the test coil is wound: (Fig. 1)

$$\mu_i = \frac{L}{4\pi N^2} \cdot \frac{\ell}{A} \cdot 10^{10}$$

where, L = effective self-inductance(H)

N = number of turns

ℓ = average length of magnetic path in the core(mm)

A = cross-sectional area of toroidal cores(mm²)

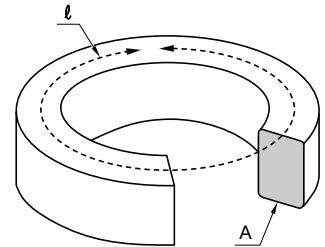

Fig. 1

1.2 INCREMENTAL PERMEABILITY, μ_Δ , AND REVERSIBLE PERMEABILITY, μ_{rev}

Incremental permeability is determined by the following formula and is defined as the permeability of a material to a low AC magnetic field superposed on a larger DC magnetic field:

$$\mu_\Delta = \frac{\Delta B}{\Delta H}$$

where, ΔB = incremental flux density(gauss)

ΔH = incremental field intensity(oersted)

Reversible permeability is defined as the limiting value of incremental permeability occurring at the zero amplitude of the alternating magnetic field. It is a function of the DC flux density B and takes the maximum value when B is the zero. Its value decreases as B increases.

Since the DC flux density varies with the core shape and also with the magnitude of the gap, it is not proper to apply a reversible permeability determined on a toroidal core to cores of other shapes such as E type, P type, etc. Hence, values of reversible permeability are determined separately for individual core shapes and gaps.

1.3 EFFECTIVE PERMEABILITY, μ_e

The effective permeability is determined by the following formula:

$$\mu_e = \frac{L \times 10^{10}}{4\pi N^2} \cdot \sum \frac{\ell}{A}$$

where, L = effective self-inductance(H)

N = number of turns

$$\sum \frac{\ell}{A} = C_1 = \text{core constant(mm}^{-1}\text{)}$$

This formula is used also when some leakage flux exists in the magnetic circuit due to an air gap introduced in it.*

Note* :Magnetic-core loss coefficient, temperature coefficient, disaccommodation and other magnetic characteristics due to an air gap in the magnetic circuit very nearly directly with effective permeability, as long as the leakage flux at the air gap is not appreciably large. If the leakage is not negligible, a correction must be made on these characteristics for the leakage flux.

1.4 APPARENT PERMEABILITY, μ_{app}

Apparent permeability is defined as the ratio of the two inductance values measured. One on the test coil only(L_0), the other on coil and core(L). This is determined by the following formula:

$$\mu_{app} = \frac{L}{L_0}$$

where, L = inductance of test coil with core(H)

L_0 = inductance of test coil without core(H)

Normally, an apparent effective permeability refers to an open magnetic circuit.

Please be sure to request delivery specifications that provide further details on the features and specifications of the products for proper and safe use. Please note that the contents may change without any prior notice due to reasons such as upgrading.

2. MAGNETIZATION CURVE

2.1 STATIC MAGNETIZATION CURVES

In magnetic material that has been completely demagnetized, the curve traced by the rising value of flux density B as a function of the field intensity H being raised from the point of origin(0) is referred to as INITIAL MAGNETIZATION CURVE.

If field intensity is raised further, a point will be reached where the material becomes saturated with flux and the curve levels off: the SATURATION FLUX DENSITY, B_{sat}, refers to that value of flux. As the field intensity is reduced to zero from the saturation point, the flux density decreases and settles at a certain value above zero: this value of remaining flux density is referred to as REMANENCE, B_r. To reduce the remanence to zero, field intensity must be increased in the negative(reverse) direction: the level of this reversed field intensity required for reducing remanence to zero is termed COERCIVITY, H_{cb}.

2.2 RELATIONSHIP BETWEEN HYSTERESIS LOOP AND PERMEABILITY

Graphic models of initial permeability and reversible permeability as concepts are given on the magnetization curve in Fig.2.

The constants relative to magnetization curve are graphically represented in Fig.3.

$$\mu_{rev} = \lim_{\Delta H \rightarrow 0} \frac{\Delta B}{\Delta H} = \tan \theta_r$$

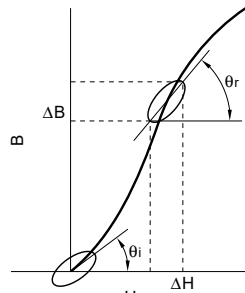

Fig. 2

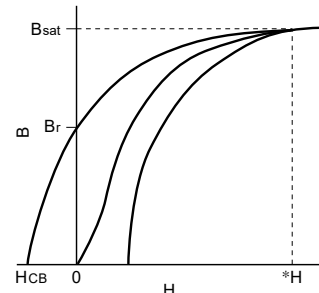

Fig. 3

*Ex' *H5A=1194A/m

3. CORE LOSS

3.1 LOSS FACTOR, tan δ

Core-loss factor, tan δ, is defined as the ratio of core-loss resistance to reactance, and consists of three components; namely, hysteresis loss, eddy-current loss and residual loss, and is expressed by the following formula:

$$\tan \delta = \frac{R_m}{\omega L} = h_1 \sqrt{\frac{L}{V}} i + e_1 f + c_1$$

where, R_m = core-loss resistance(Ω)

ω = 2πf, angular velocity(radians/sec.)

L = inductance of test coil with core(H)

V = volume of core(cm³)

f = frequency of test current(Hz)

h₁ = hysteresis loss coefficient

e₁ = eddy-current loss coefficient

c₁ = residual loss coefficient

i = current(A)

The loss factor is normally determined by effecting measurement with a small magnetic field, and is treated as a loss distinct and apart from the hysteresis loss. In other words, the loss coefficient is defined by the following formula:

$$\tan \delta = e_1 f + c_1$$

3.2 RELATIVE LOSS FACTOR, tan δ/μ_i

Addition of an air gap to a magnetic circuit changes the values of its loss factor and effective permeability. The amounts of change are nearly proportional to each other, so that the loss factor per unit effective permeability may be used as a coefficient which, as defined as tan δ/μ_i, indicates a characteristic of the magnetic material.

$$\tan \delta / \mu_i = \frac{1}{\mu_i} (e_1 f + c_1)$$

It follows therefore that the loss factor for a practical core can be expressed in the following formula:

$$(\tan \delta)_c = \tan \delta / \mu_i \times \mu_e$$

Where (tan δ)_c represents the particular loss factor.

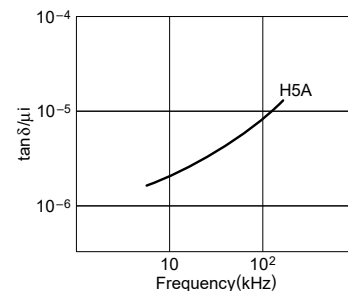

Fig. 4

⚠ Please be sure to request delivery specifications that provide further details on the features and specifications of the products for proper and safe use. Please note that the contents may change without any prior notice due to reasons such as upgrading.

3.3 RELATIVE HYSTERESIS LOSS COEFFICIENT, h_{10}^*

When an air gap is introduced into a magnetic circuit, its hysteresis loss coefficient, h_1 , changes approximately as 3/2 power of the effective permeability. On the basis of this fact, relative hysteresis loss coefficient, h_{10} , is defined as the value of this loss h_1 corrected to the condition of $\mu+1000$. The value of h_{10} for different magnetic materials can be compared for comparative evaluation of the materials. For this purpose, the relative hysteresis loss coefficient is determined for and assigned to each material.

$$h_{10} = h_1 \cdot \left(\frac{1000}{\mu_i}\right)^{3/2}$$

Thus, the hysteresis loss coefficient, $\tan\delta_h$, for a practical core is expressed by the following formula:

$$\tan\delta_h = h_{10} \cdot \left(\frac{\mu_i}{1000}\right)^{3/2} \cdot \sqrt{\frac{L}{V}} \cdot i \quad \text{Note* : } h_{10} \text{ is read "h one-zero."}$$

The relationship between η_B and other constants are as follows:

$$\begin{aligned} \eta_B &= 19.9h_{10} \times 10^{-6} \\ \eta_B &= 1.12 \times h' / \mu^2 \\ \eta_B &= 896 \times h / \mu^2 \\ h_{10} &= 50.3\eta_B \times 10^3 \end{aligned}$$

where, η_B = hysteresis material constant in IEC

$$\frac{h'}{\mu^2} = \text{hysteresis constant in DIN}$$

$$\frac{h}{\mu^2} = \text{hysteresis constant in Jordan}$$

3.4 QUALITY FACTOR, Q

Quality factor is defined as the reciprocal of the loss coefficient, as follows:

$$Q = \frac{1}{\tan\delta} = \frac{\omega L}{R_m}$$

3.5 EFFECTIVE QUALITY FACTOR, Q_e

The effective quality factor refers to the loss coefficient of a coil complete with a ferrite core, and is the reciprocal of that coefficient:

$$Q_e = \frac{\omega L}{R_{eff}}$$

Where R_{eff} is the effective loss resistance of the coil.

3.6 APPARENT QUALITY FACTOR, Q_{app}

This factor is the ratio of the two values of effective quality factor measured on a test coil, one(Q_e) is coil with core, and the other(Q_0) is coil without core.

$$Q_{app} = \frac{Q_e}{Q_0}$$

where, Q_e = coil with core

Q_0 = coil without core

4. TEMPERATURE CHARACTERISTICS

4.1 TEMPERATURE COEFFICIENT OF INITIAL PERMEABILITY, $\alpha_{\mu i}$

This temperature coefficient is defined as the change of initial permeability per degree C over a prescribed temperature range. This change is expressed in terms of fraction of the original value of initial permeability. It is determined by the following formula:

$$\alpha_{\mu i} = \frac{\mu_{i2} - \mu_{i1}}{\mu_{i1}} \cdot \frac{1}{T_2 - T_1}$$

where, μ_{i1} = initial permeability at temperature T_1

μ_{i2} = initial permeability at temperature T_2

The value of T_1 is normally taken at 20°C. The coefficient is expressed in units of 10^{-6} .

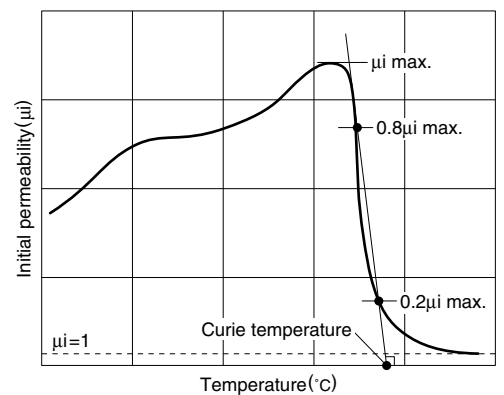

Fig. 5

⚠ Please be sure to request delivery specifications that provide further details on the features and specifications of the products for proper and safe use. Please note that the contents may change without any prior notice due to reasons such as upgrading.

4.2 TEMPERATURE FACTOR OF INITIAL PERMEABILITY, α_F

The change of temperature coefficient, α_{μ} , due to an air gap added to a magnetic circuit is nearly proportional to the change of effective permeability. On the basis of this fact, temperature factor of permeability, α_F , is defined as the value of temperature coefficient, α_{μ} , per unit permeability, and is determined by the following formula:

$$\alpha_F = \frac{\alpha_{\mu}}{\mu_i} = \frac{\mu_{i2} - \mu_{i1}}{\mu_{i1}^2} \cdot \frac{1}{T_2 - T_1}$$

The value so determined is assigned to each material as its characteristic. For the temperature coefficient of a practical core, the following formula is used.

$$\alpha_{\mu} = \alpha_F \times \mu_e$$

4.3 CURIE TEMPERATURE T_c

The critical temperature at which a core transfers from ferromagnetism to paramagnetism.

Note: There are many ways to determine the Curie temperature. At TDK, however, it is determined as shown in Fig.5.

5. PHENOMENON OF GRADUAL DECREASE IN PERMEABILITY

5.1 SPONTANEOUS DECREASE OF PERMEABILITY

In ferrite cores, the permeability begins to decrease upon formation by sintering and continues to decrease with the lapse of time. This property is referred to as the spontaneous decrease of permeability.

In general, the rate of spontaneous permeability decrease is approximately linear when it is related to the logarithm of time(log t) and, therefore, becomes negligibly small in about a month's time after sintering. The magnitude of this decrease in terms of μ_e/μ_i can be reduced substantially with increasing air gap.

5.2 DISACCOMMODATION, D

Disaccommodation, as will be noted in the following formula which determines its value: The time rate of initial permeability changes at normal temperature in a core that has just been AC demagnetized, where the core is kept free from mechanical or thermal stress of any kind.

$$D = \frac{\mu_1 - \mu_2}{\mu_1} \times 100(\%)$$

where, μ_1 = initial permeability noted immediately after the material is AC demagnetized.

μ_2 = initial permeability noted some time after the material is AC demagnetized.

Disaccommodation and spontaneous decrease are two distinct concepts but some correlation is noted to exist between the two. The disaccommodation of a material is considered suggestive of its property of spontaneous decrease and also the permeability change that the material would exhibit when subjected to mechanical or magnetic shocks.

5.3 DISACCOMMODATION FACTOR, D_F

For cores with air gap, the disaccommodation of the material in the circuit is nearly proportional to its effective permeability. The value of disaccommodation per unit permeability is designated as the disaccommodation factor(D_F)-one of the characteristics-and is determined for each material.

$$D_F = \frac{\mu_1 - \mu_2}{\log_{10} \frac{t_2}{t_1}} \cdot \frac{1}{\mu_1^2} (t_2 > t_1)$$

where, μ_1 = initial permeability noted at time t_1 after the material is AC demagnetized.

μ_2 = initial permeability noted at time t_2 after the material is AC demagnetized.

Normally t_1 , is 1 minute, and t_2 is 10 minutes; but up to 10 and 100 minutes, respectively, are occasionally used.

For a practical magnetic core, the following formula is used to determine its disaccommodation:

$$D = D_F \times \mu_e$$

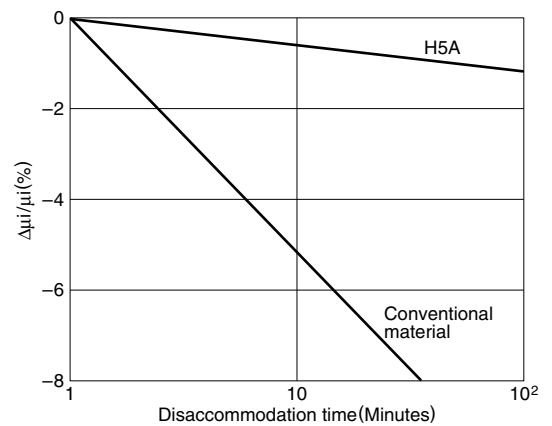

Fig. 6

Please be sure to request delivery specifications that provide further details on the features and specifications of the products for proper and safe use. Please note that the contents may change without any prior notice due to reasons such as upgrading.

6. INDUCTANCE COEFFICIENT, AL

Inductance coefficient is defined as the self-inductance per unit turn of a coil of a given shape and dimensions wound on a magnetic core, and is determined by the following formula:

$$A_L = \frac{L}{N^2}$$

where, L = self-inductance of coil with core(H)
N = number of turns

This coefficient is normally expressed in units of 10⁻⁹H(1nH).
Shapes and dimensions are separately prescribed for test coils to be used in the measurement for AL.

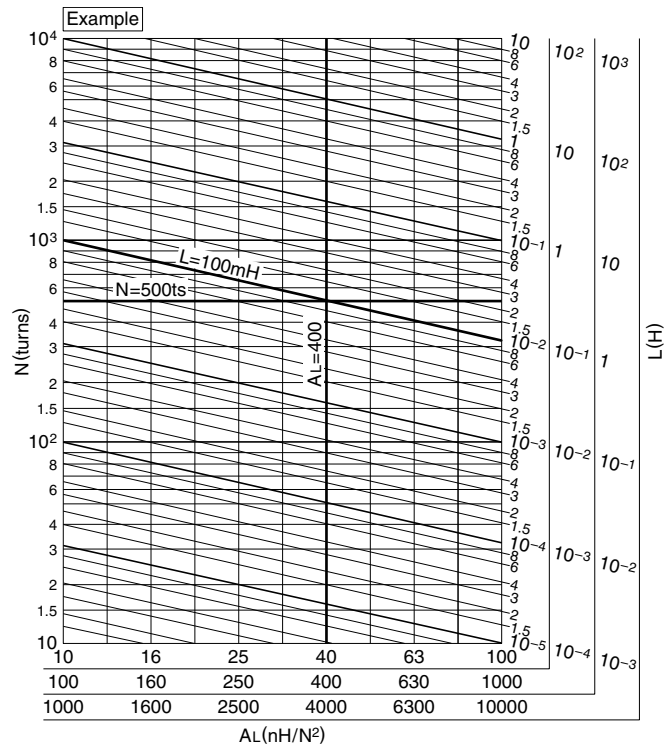

Fig. 7

7. WINDING COEFFICIENT, α

Winding coefficient is defined as the number of coil turns required for producing unit self-inductance in a coil of a given shape and dimensions wound on a core, and is determined by the following formula:

$$\alpha = \frac{N}{\sqrt{L}}$$

where, L = self-inductance of coil with core(H)
N = number of turns

Normally 1mH is taken for the L in this case.

8. ELECTRICAL RESISTIVITY, ρv

Electrical resistivity is the resistance measured by means of direct voltage of a body of ferromagnetic material having a constant cross-sectional area.

9. DENSITY, db

Specific gravity of a magnetic core is calculated from its volume and mass, as shown in below.

$$d_b = W/V(\text{kg/m}^3)$$

where, W = mass of the magnetic core
V = volume of the magnetic core

Note: The symbol and the catalog of this data are in accordance with IEC Publication 60401-3.

⚠ Please be sure to request delivery specifications that provide further details on the features and specifications of the products for proper and safe use.
Please note that the contents may change without any prior notice due to reasons such as upgrading.